

# One DISH – several bands and other uses ! SM6PGP



# Main application EME

- First EME band 5.7 GHz – first QSO K5GW, feb 2013
  - 2:nd band 1.3 GHz – goal was to work SK6OSO (april 2013)
  - 3:rd band 3.4 GHz (june 2013)
  - 4 :th - RX attempts 10 GHz
  - 5:th band 2.3 GHz (march 2019) maybe first and last QSO:s on this band
- 
- Reception of SAT TV, some kind of SAT TV DX, 10.7 – 12.7 GHz
- 
- QO-100 – narrowband - first QSO 12 feb 2019
  - QO-100 – wideband reception of DATV

# Main application EME

- 5.7 GHz – a real mess in the dish - straps
- 1296 - another mess ...
- 3400 – even worse – foam to keep feed in place
- Something has to be done !

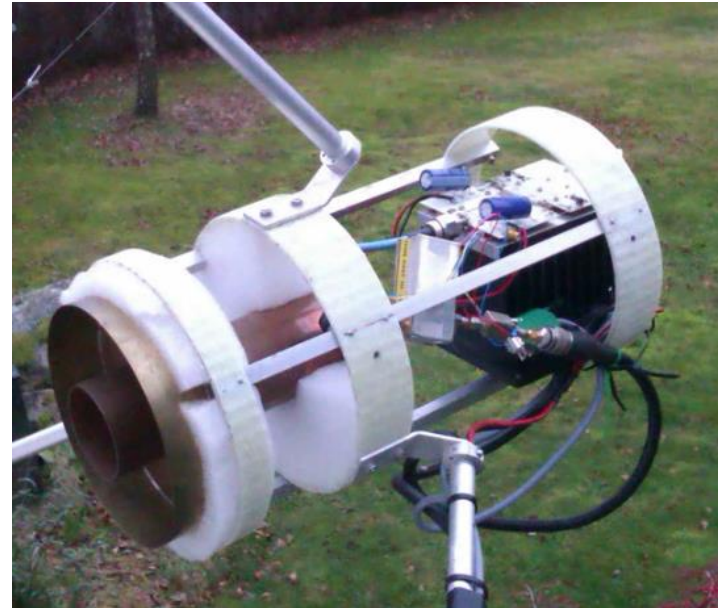

How to get all equipment running and easily exchangeable ?

Write your own system specification !  
and try to stay with that

Mechanical & Electrical

This can have some background  
and influence from....everyday QRL

# How to get all equipment running and easily exchangeable ?

## Write your own system specification !

### Mechanical

- All "RF-heads" frames built with the same dimensions
- Feed phase center adjusted for individually for each RF-head
- The same type of cables/connectors for all equipment installed at dish focus and at the same place.

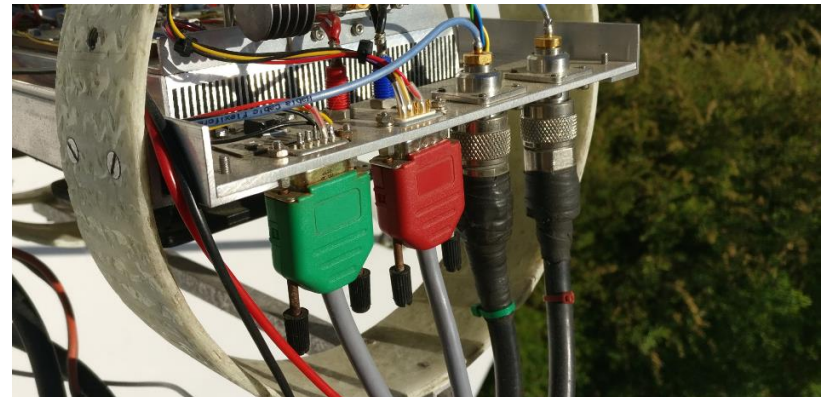

# How to get all equipment running and easily exchangeable ?

## Mechanical

- 200 x 410 mm  
approx 8" x 16"
- Must fit within  
210 mm diam  
(8" diam)
- Feed holder 3D  
printed in ABS  
plastic. Easy to  
make new one if  
feed position  
need to be  
changed.

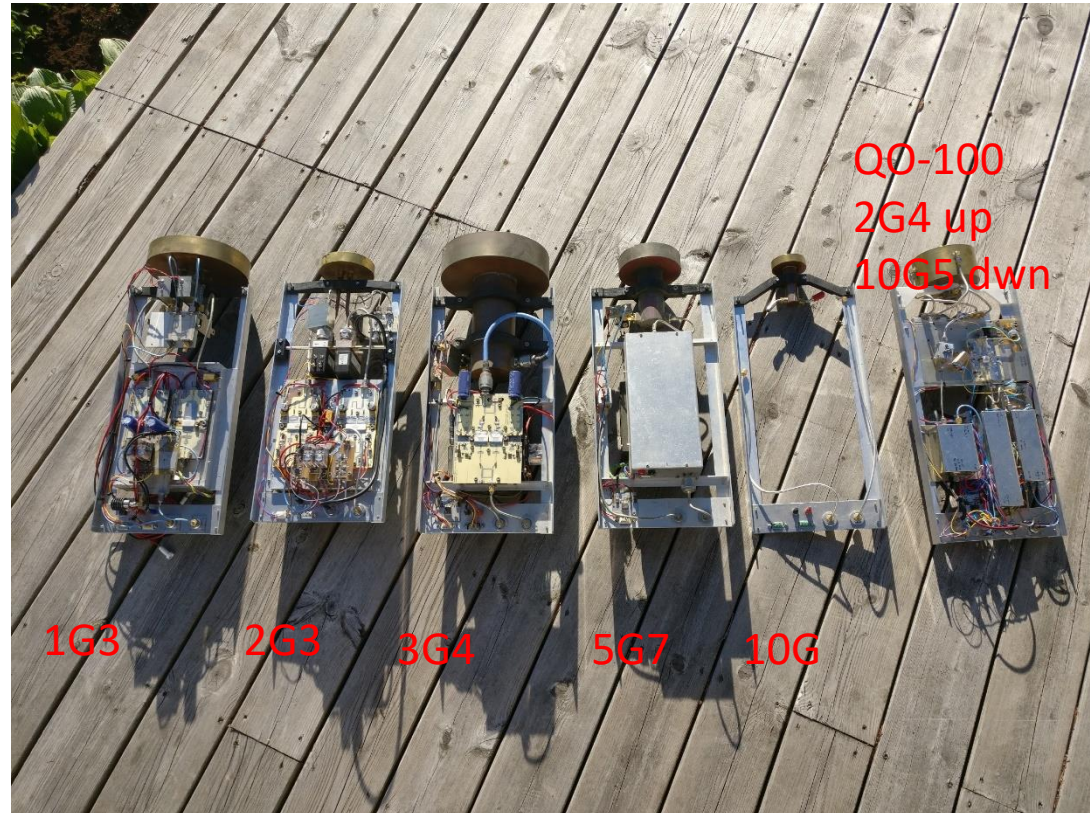

# How to get all equipment running and easily exchangeable ?

## Write your own system specification !

### Electrical

- TX IF (144 MHz) to all xverters = 20 dBm CW keydown for full power
- Interface description – connector pin-numbers with function and levels
- Sequencing in each transverter
- 12V to xverters, 28V to relays
- Powersupply to power amps – **problem = risk**, 1G3 & 5G7 48V, 3G4 need 32V, 2G3 need 28V, 10G probably 40V – safety board design on paper but not built – No human errors .... yet ;-)

# How to get all equipment running and easily exchangeable ?

## Interface description RF-head connectors

### RF-head LNA connector (GREEN)

Pin

- 1 +28V to LNA protection relay
- 2 +12V to LNA (continuous)
- 3 -
- 4 -
- 5 -
- 6 28V\_RTN
- 7 12V\_RTN
- 8 -
- 9 -



### RF-head Power Amp connector (RED)

Pin

- 1 -
- 2 +12V continuous (to pwr detector)
- 3 -
- 4 +28V at TX (for DC power relay)
- 5 12V\_RTN
- 6 -
- 7 28V\_RTN (DC power relay)
- 8 1-wire data (temperature sensors)
- 9 Power meas 0-5V => +10 to +60 dBm



# System block diagram

EME RF-head(s) at SM6PGP

Cables from xverter to RF-head  
5 m Aircom plus

3G4 & 5G7 Front ends (& 10G soon)

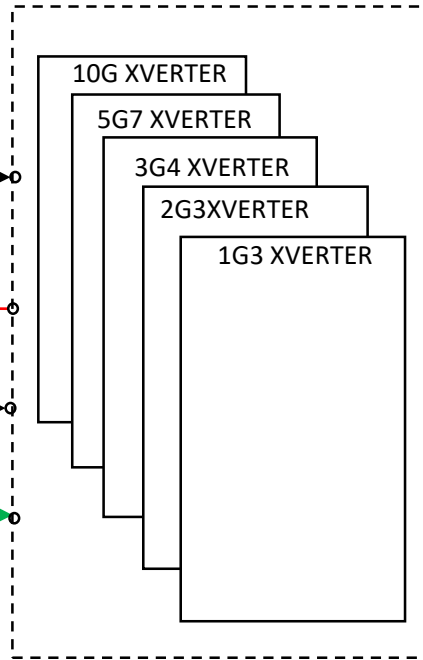
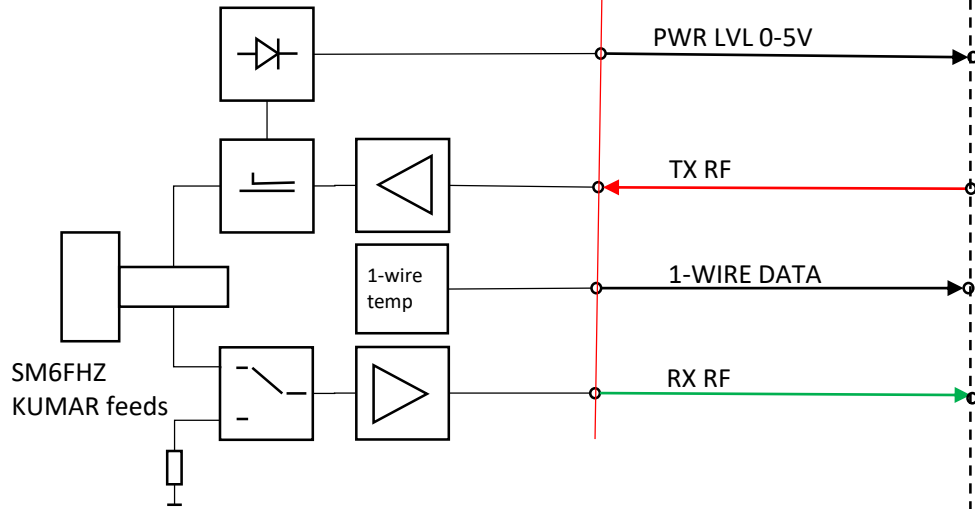

1-WIRE DATA to PC  
PWR LVL 0-5V => 10-60 dBm

TX IF (+10V at TX)  
RX IF

1G3 & 2G3 Front ends

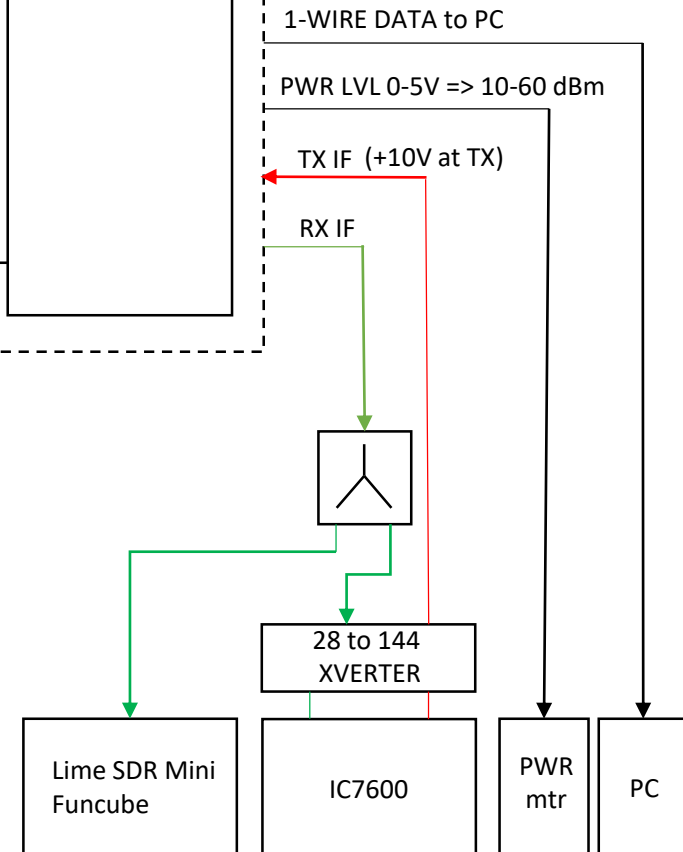
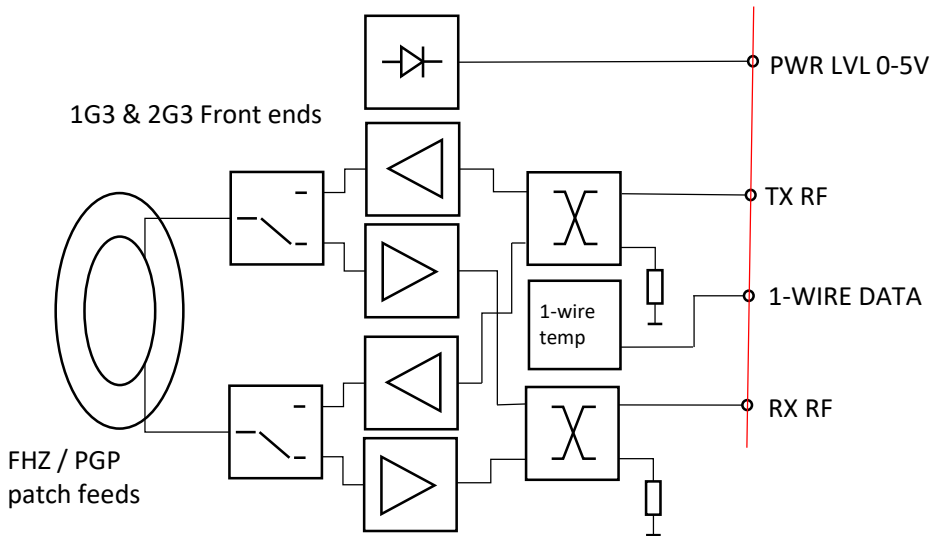

# Off EME topic → QO-100

- Wanted to use my dish for QO-100, Goal to be QRV when satellite is opened !
- In sweden 100mW is allowed at 2400 MHz, calculations showed that with a 2.3m dish this power level would be sufficient for at least CW.
- I persuaded Ingolf/SM6FHZ to design a dualband feed, 2.4 GHz circular and 10G5 linear with both vertical and horizontal ports. He suggested a coaxial cup feed with two probes fed 90 degrees out of phase.

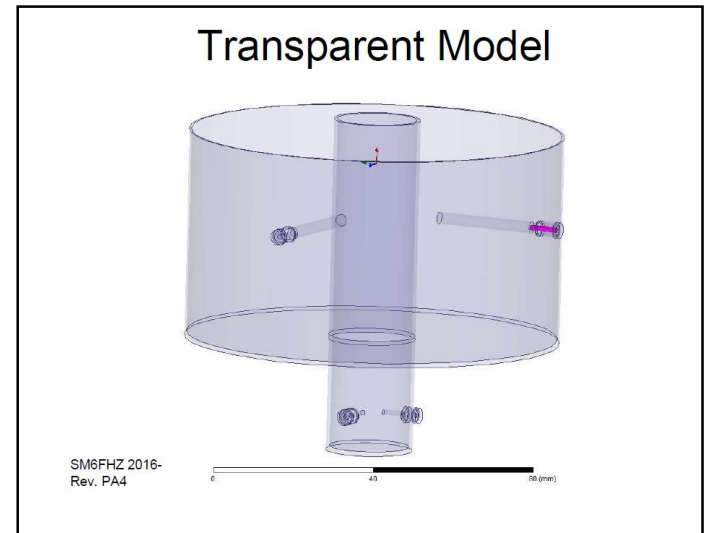
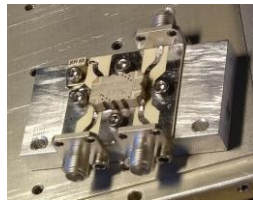

# Off EME topic → QO-100

- Wanted to use almost the same HW for narrowband and wideband with just a switch between vertical and horizontal
- Ended up with my own design for both the downconverter and upconverter.
- RX – SDR running at 1465 MHz, funcube dongle or Lime SDR mini

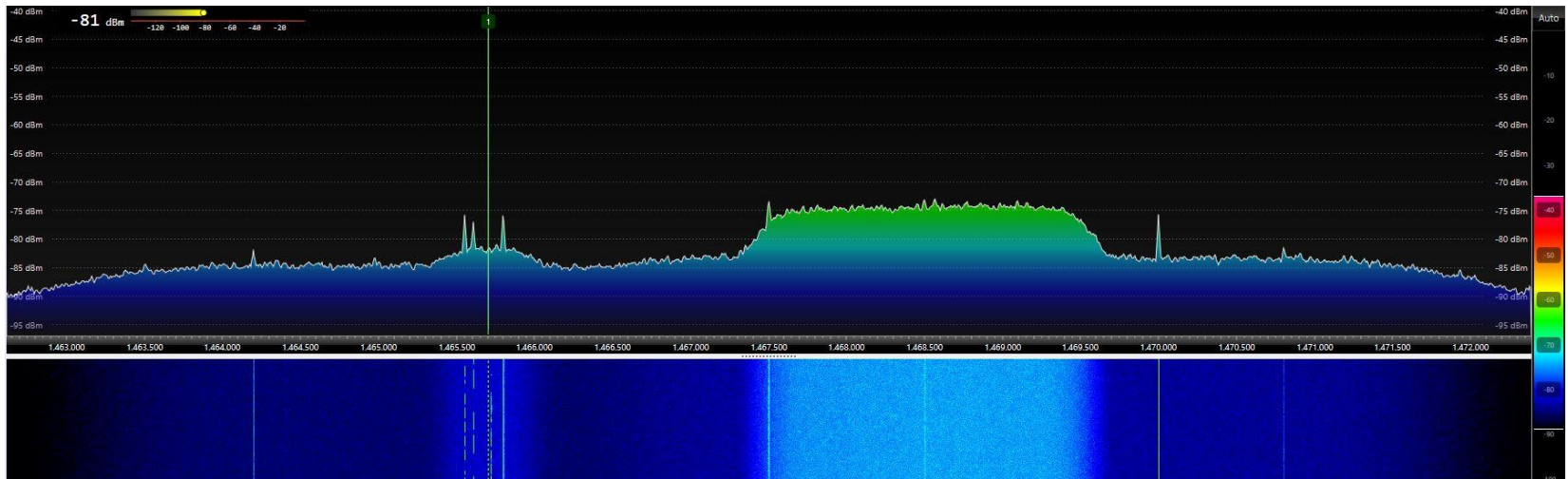

# Off EME topic → QO-100

## LO CHAIN 9024/2256 MHz SM6PGP

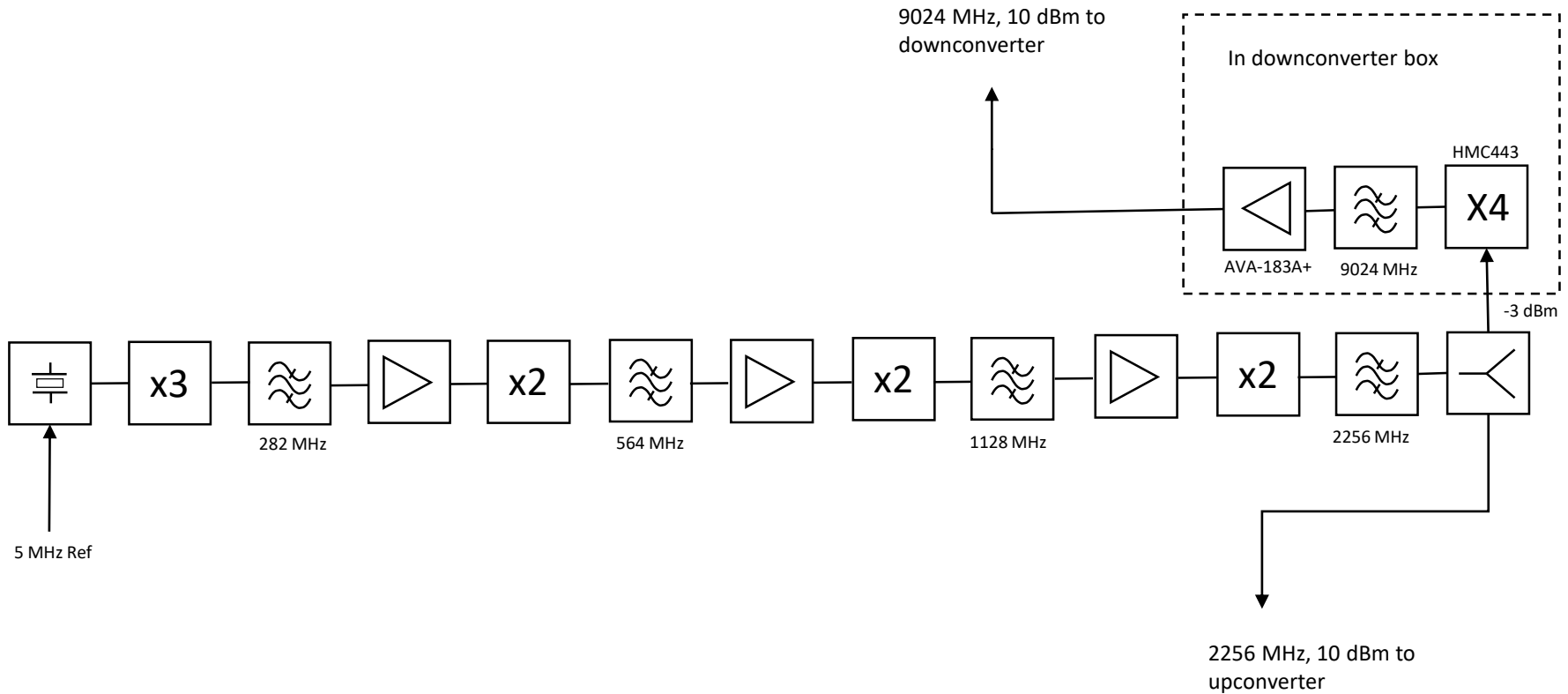

# Off EME topic → QO-100

LO CHAIN 9024/2256 MHz SM6PGP

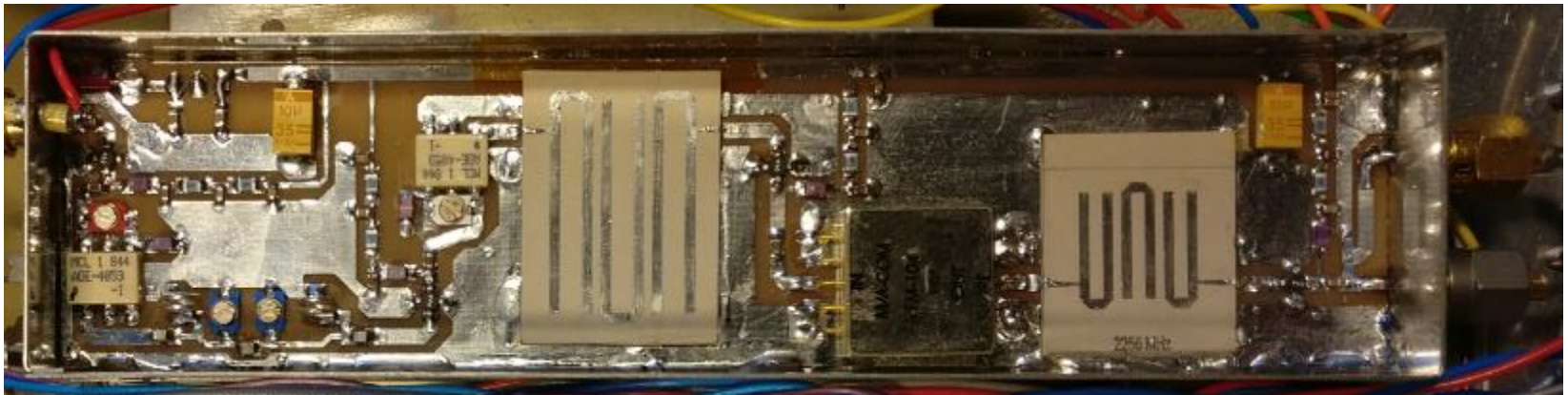

# Off EME topic → QO-100

## DOWN CONVERTER 10500 MHz SM6PGP

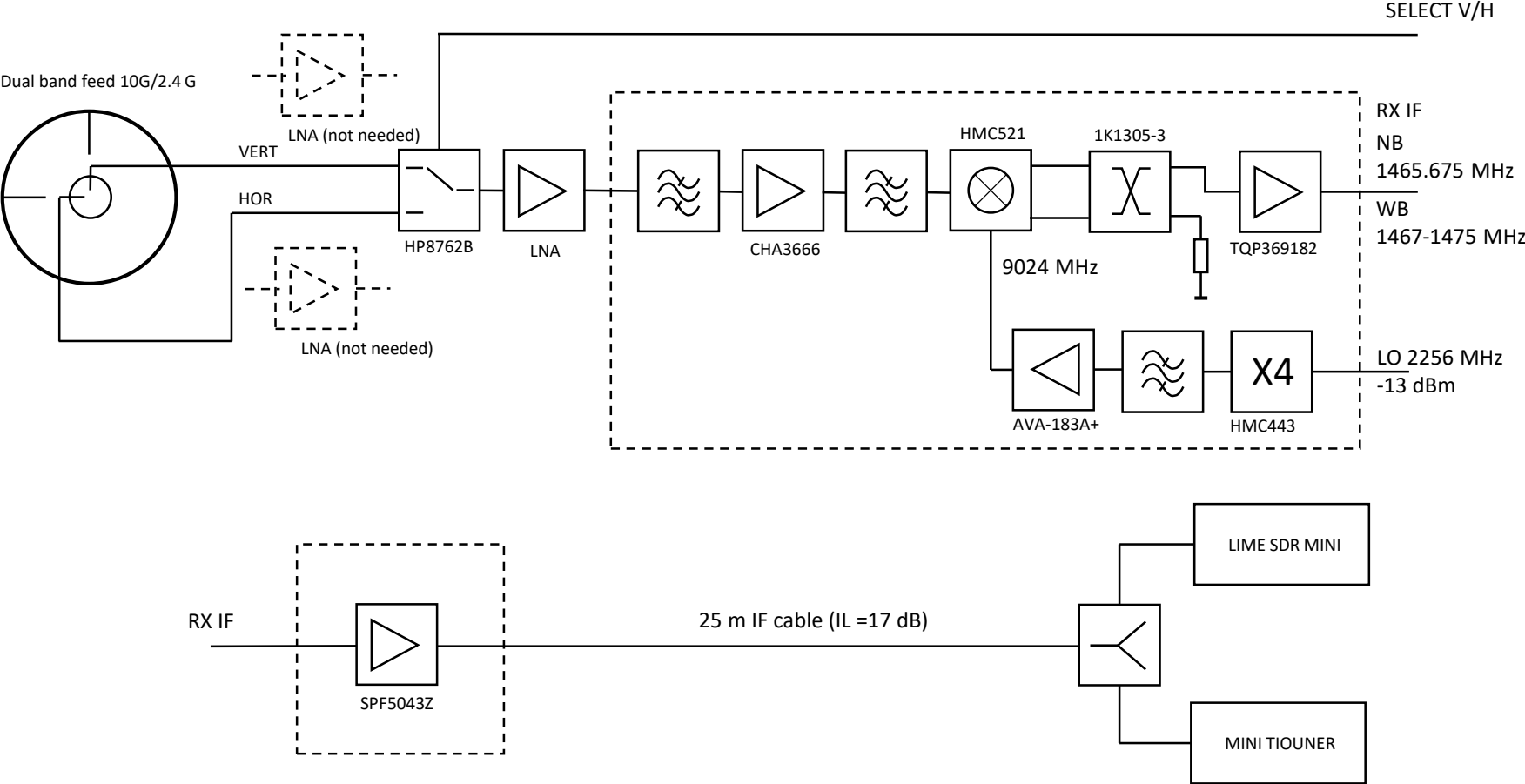

# Off EME topic → QO-100

DOWN CONVERTER 10500 MHz SM6PGP

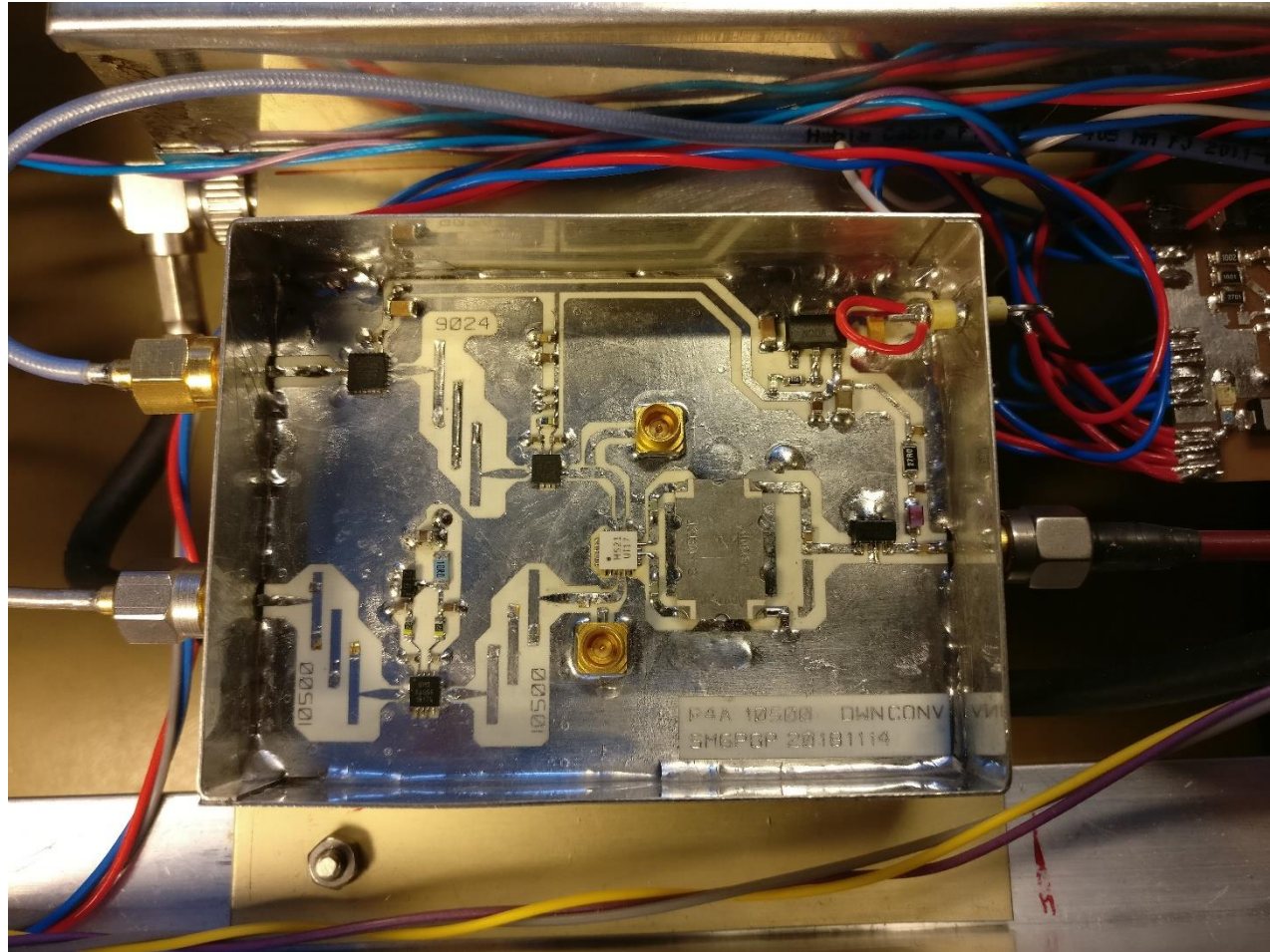

# Off EME topic → QO-100

## UP CONVERTER 2400 MHz SM6PGP

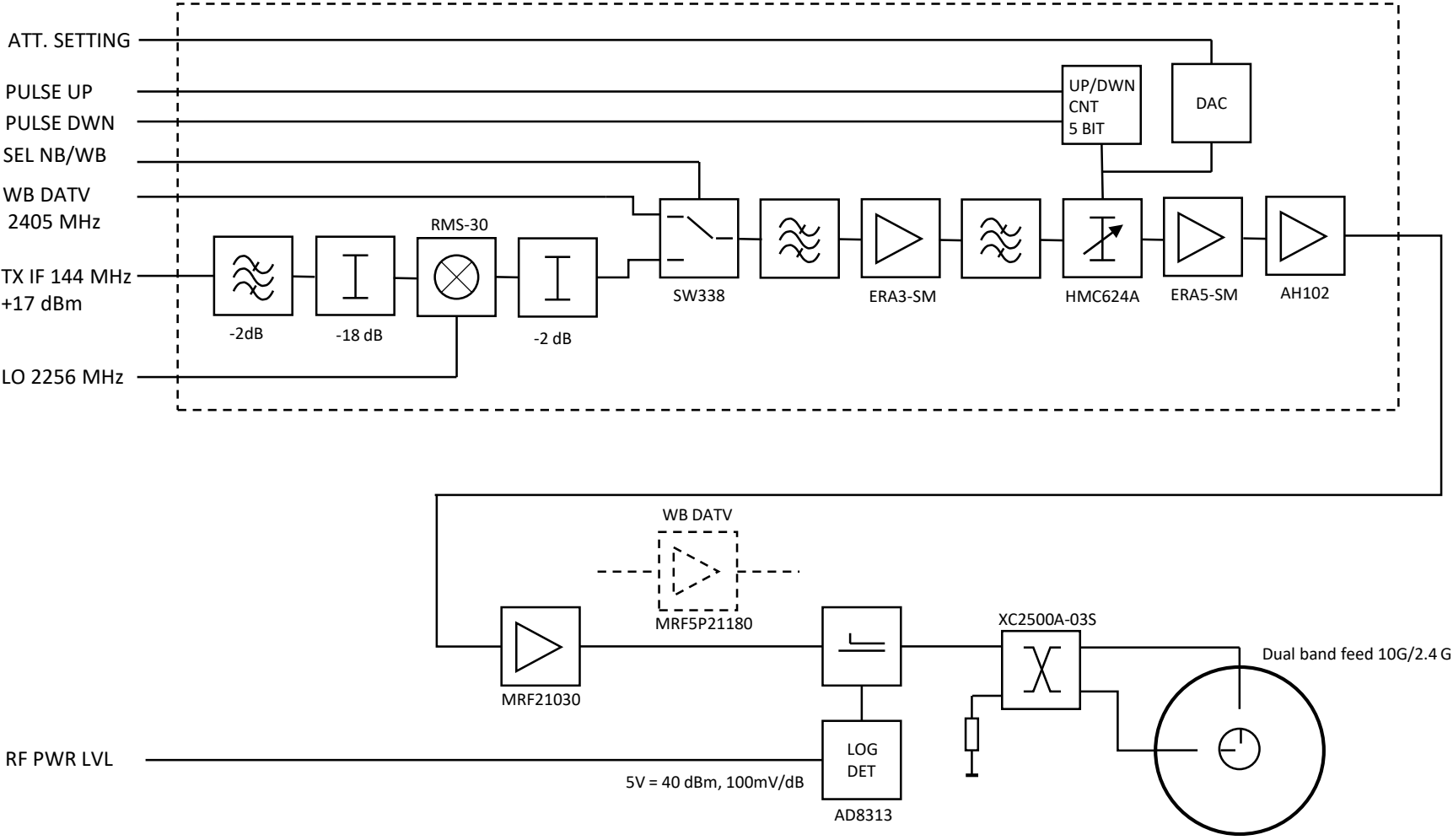

# Off EME topic → QO-100

UP CONVERTER 2400 MHz SM6PGP

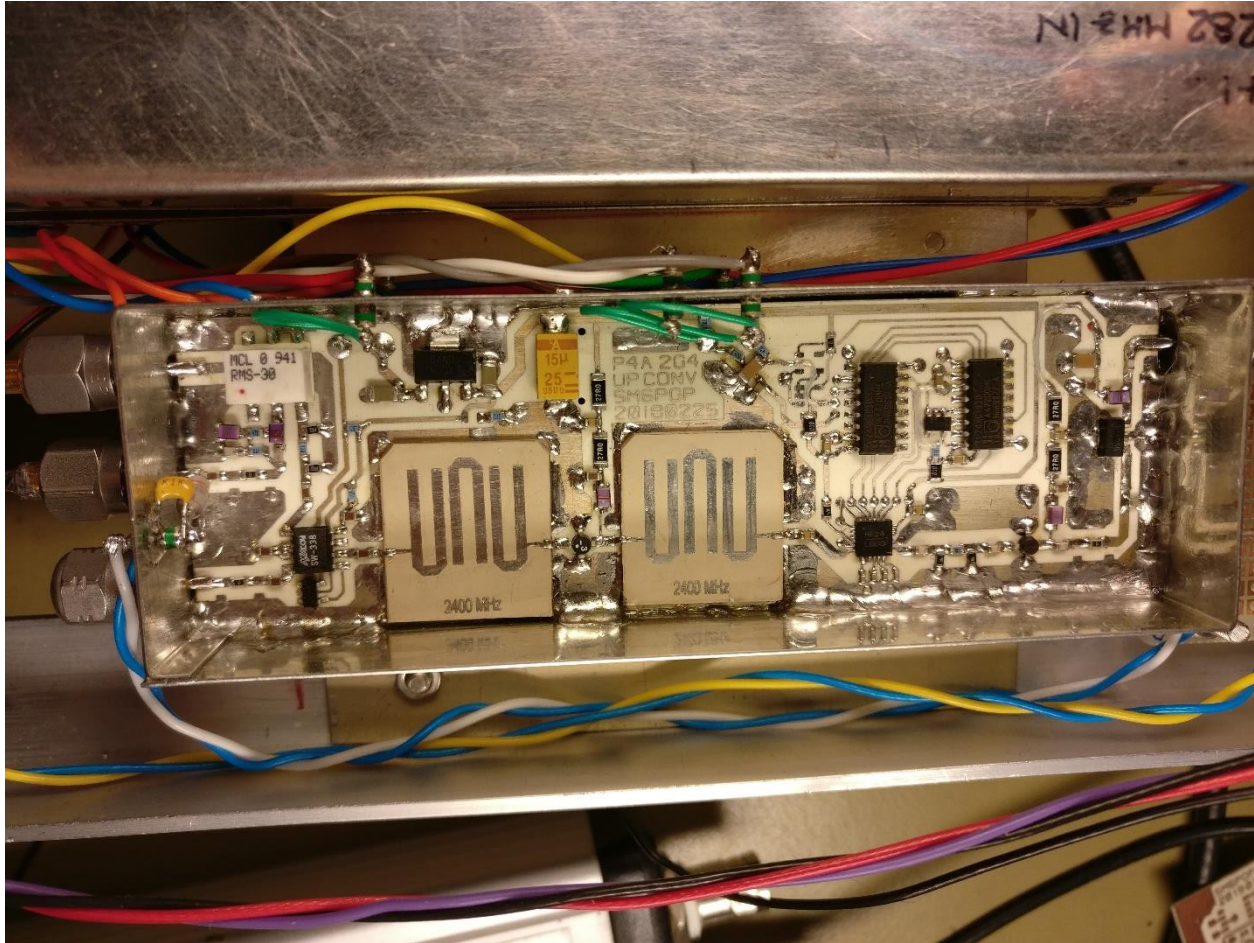

# Off EME topic → QO-100

1:ST RECEIVE TEST NB/WB TRANSPONDER NOISE SM6PGP

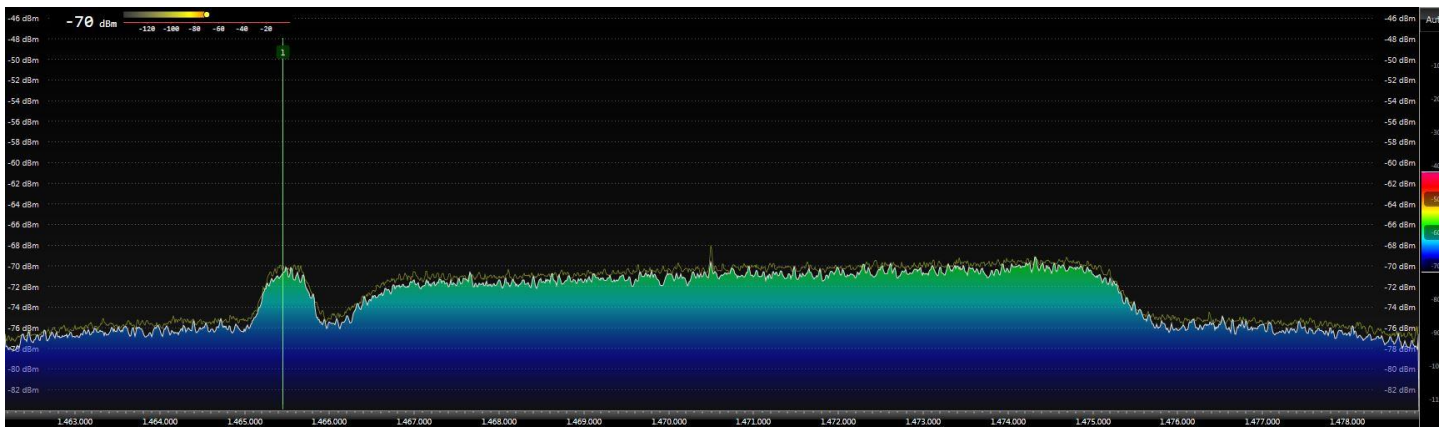
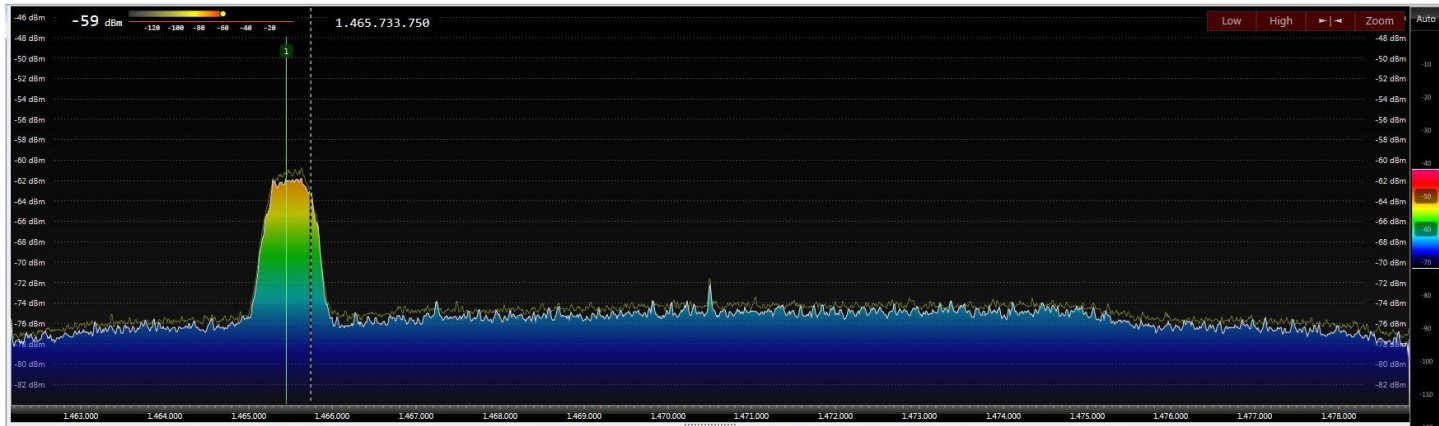

# Off EME topic → QO-100

## RECEIVE DATV with MiniTioner Express

The image displays three screenshots of the MiniTioner Express software interface, illustrating the process of receiving DATV (Digital Amateur Television) signals.

**Top Screenshot:** Shows the initial reception of a signal. The central video window displays a rocket launch labeled "LAUNCH: ES'HAIL-2". The interface includes a "SR (kS) Freq (kHz)" table with values: SR2000 (1471 MHz), SR125 (2395 MHz), SR250 (437 MHz), SR1000 (437ve MHz), and SR22000 (437ve MHz). The "Web Station ID:1" shows "SM6PGP". The "PIDs" list includes A71A, F6D2P-H264, HDlowSR, and France24. The "TELEMETRY" section shows "STAGE 2" with "SPEED 00309 km/h" and "ALTITUDE 00.7 km".

**Middle Screenshot:** Shows the reception of a test signal. The central video window displays a test pattern labeled "MODTS" and "LOC: HILTON, YARM". The "SR (kS) Freq (kHz)" table shows: SR2000 (104925 MHz), SR125 (104925 MHz), SR250 (437 MHz), SR0333 (437ve MHz), and SR22000 (437ve MHz). The "Web Station ID:1" shows "SM6PGP". The "PIDs" list includes Digital TV, F6D2P-H264, HDlowSR, France24, QRZ DX, and RaspberryP. The "Format" section shows "Width: 320" and "Height: 240".

**Bottom Screenshot:** Shows the reception of a signal with a different carrier lock. The central video window displays a test pattern. The "SR (kS) Freq (kHz)" table shows: SR2000 (104925 MHz), SR125 (104925 MHz), SR250 (437 MHz), SR0333 (437ve MHz), and SR22000 (437ve MHz). The "Web Station ID:1" shows "SM6PGP". The "PIDs" list includes Digital TV, F6D2P-H264, HDlowSR, France24, QRZ DX, and RaspberryP. The "Format" section shows "Width: 320" and "Height: 240".

The interface also features various meters and controls, including "Carrier Lock" (95%), "Timing Lock" (52%), "Power RF" (-60 dBm), "MER" (36 dB), and "Constellations". The "Web Station ID:1" section includes "Fjårås J067BK", "Ant. Dir.: East", "Gain 12 dB", and "Timing 3 sec". The "PIDs" section includes "AutoPID", "PID Video", "PID audio", "Codec", "Format", "Station", "Provider", "Codecs", and "Audio level".

**THANK YOU !**