



**Septum Feeds
for
10 GHz EME**

**Swedish EME-meeting May 2015
SM6FHZ and SM6PGP**

Outline



- Prerequisite
- Features
- Design criteria / considerations (10 pages)
 - Wave Guides
 - Wave Guide interface
 - Septum
 - Kumar choke, size, position etc
- Alternatives to the septum polarizer (11 pages)
- Simulations versus reality (7 pages)
 - Simulation accuracy
- Performance overview (3 pages)
 - 3 cm 0.692 L W/G feed performance
 - 3 cm 0.760 L W/G feed performance
 - 3 cm Dual Mode feed performance
- Realization
- Lessons Learned
- Conclusions
- Detailed dimensions for all variants (84 pages)

Prerequisite

- My presentation at the Swedish EME-meeting 2013 contained the following septum feeds:
 - 2 designs for 23 cm, a 9cm design, a 6cm design and two 3 cm designs. All focused on dishes with a f/D in the 0.3 to 0.4 region.
 - All the presented feed used coax interfaces
- Requests from the audience at that meeting were made for 3cm feeds comprising WG-interfaces as well as feeds suitable for higher f/D 's. This will be addressed in the presentation this year.
- The existing feeds for higher bands are mostly scaled versions of 23 cm feeds. My belief is that feeds specifically designed and optimized for the specific band are needed to get the best possible performance at the band in question

Features

- 3 cm feeds from standard metric as well as standard inch plumbing copper or brass tubes
- Introducing feeds for off-set dishes with f/D of 0.5 and above
- Unprecedented top notch performance
- Focus on easy manufacturing and low tolerance sensitivity
- Suitable for f/D 's ranging from 0.32 to 0.42 plus $\sim 0.5 f/D$ for the 3 cm Dual Mode Feed
- All comprising a Kumar choke or Dual Mode structure for proper dish illumination, depending on the f/D the feed is aiming for
- All 3 cm feeds cover both 10368 and 10450 MHz
- The radiation patterns for the metric and inch tubing versions are almost identical and the radiation patterns does not change with the feeding (WG or coax) method nor does the feeding (WG/coax) dimensions change from metric to inch tubing. The different versions features are **truly modular**.

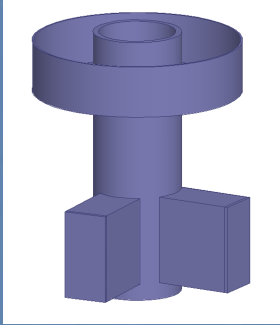

Feeds included

- 3 cm Septum feed with Kumar choke and **W/G**-interface. Standard **metric** tubing.
- 3 cm Septum feed with Kumar choke and **W/G**-interface. Standard **inch** tubing.
- 3 cm Dual Mode Septum feed for $f/D \sim 0.5$ with **coax** interface. Standard **metric** tubing
- 3 cm Dual Mode Septum feed for $f/D \sim 0.5$ with **coax** interface. Standard **inch** tubing

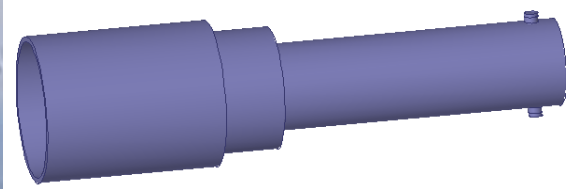

- 3 cm Dual Mode Septum feed for $f/D \sim 0.5$ with **W/G**-interface. Standard **metric** tubing.
- 3 cm Dual Mode Septum feed for $f/D \sim 0.5$ with **W/G**-interface. Standard **inch** tubing.

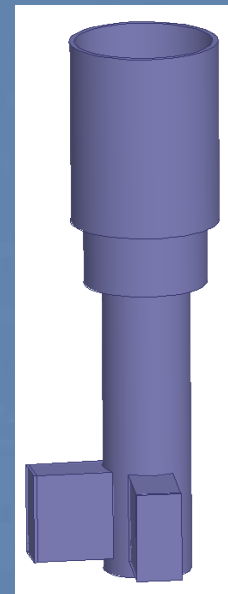

Design criteria

- We strive for
 - Optimum amplitude feed pattern
 - Flat phase response across the full dish surface (small phase errors)
 - Low axial ratio across the full dish surface (low cross polarization)
- We can not get all of this optimized at the same time, so we have to look for the best compromise.
- The W1GHZ feed efficiency and G/T evaluation S/W Feed_GT has been used for this evaluation.
 - This means that these results can be compared to the results of other feeds evaluated using the same S/W.
 - Feed_GT is the latest version of Pauls evaluation S/W and takes Cross Polar Radiation as well as radiation in the diagonal cuts into consideration for the performance calculation. Version prior to “Phase_CP” did not do that. This gives a more correct picture of the performance of each feed. The Feed_GT version also calculates G/T.
 - The G/T comparison has been made using the semi-standard dish size of 20λ . Paul used this dish size for comparison in his EME 2014 presentation.

Wave Guide modes

- The lowest mode that will propagate in a circular WG is called TE₁₁.

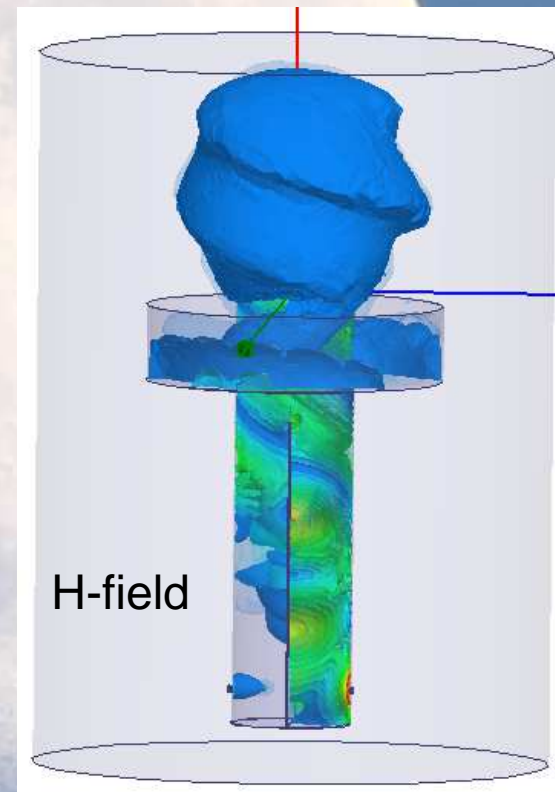
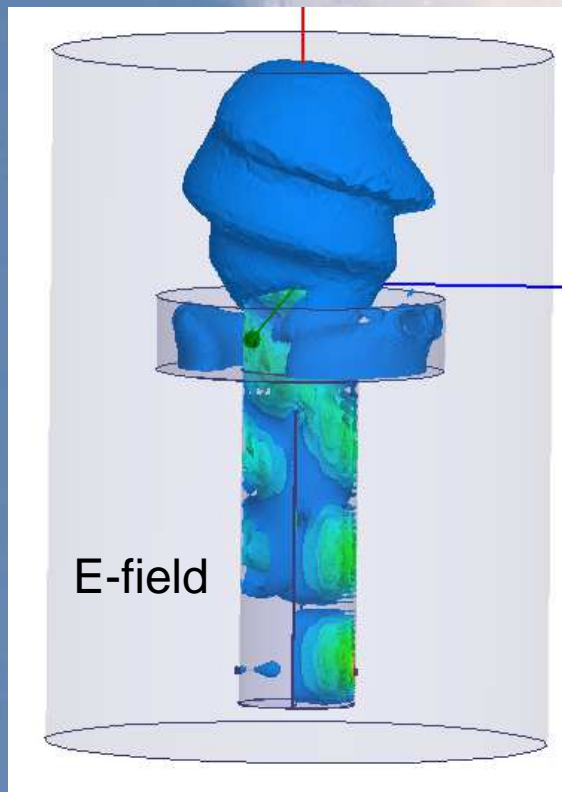

Wave Guide propagation modes

in SM6FHZ 10 GHz Dual Mode Feed at 0 degrees

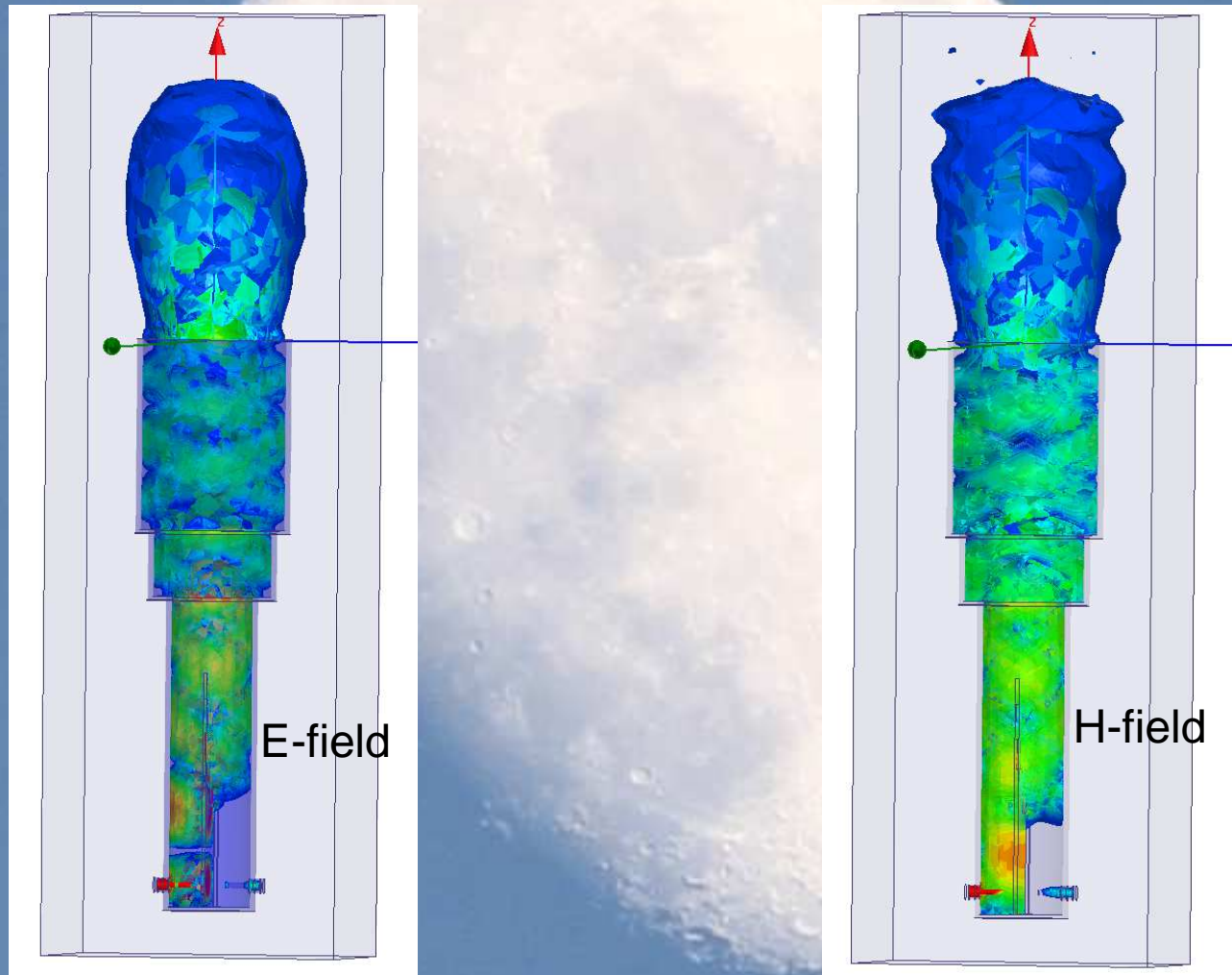

Wave Guide size and λ_g (10368 MHz) / λ_c for TE11

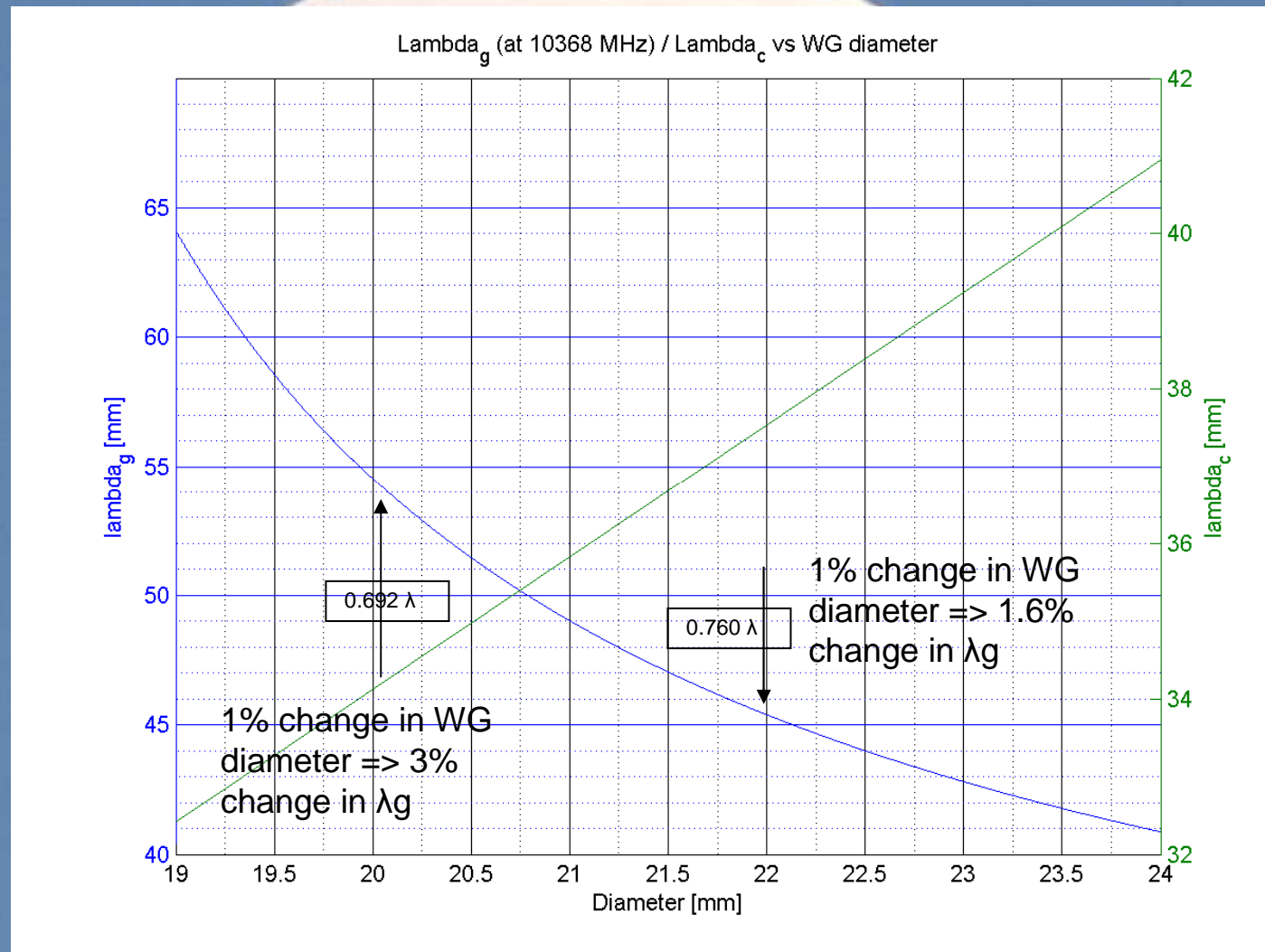

Septum considerations

- The septum shall generate a circularly polarized wave in a way that it contains only one polarization direction in each port. This ensures that we have
 - Good Axial Ratio
 - Low Cross Polar Radiation
- It shall also ensure good isolation between the two ports, Tx and Rx
- It shall do all this over a reasonable band width
- In these designs this is accomplished by using a 5 step septum plate

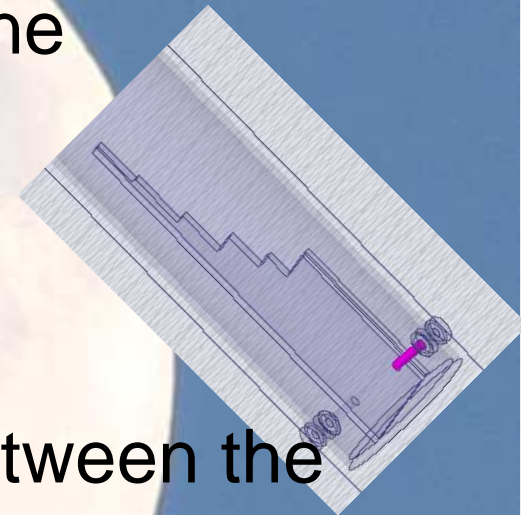

E-field variation over a full cycle

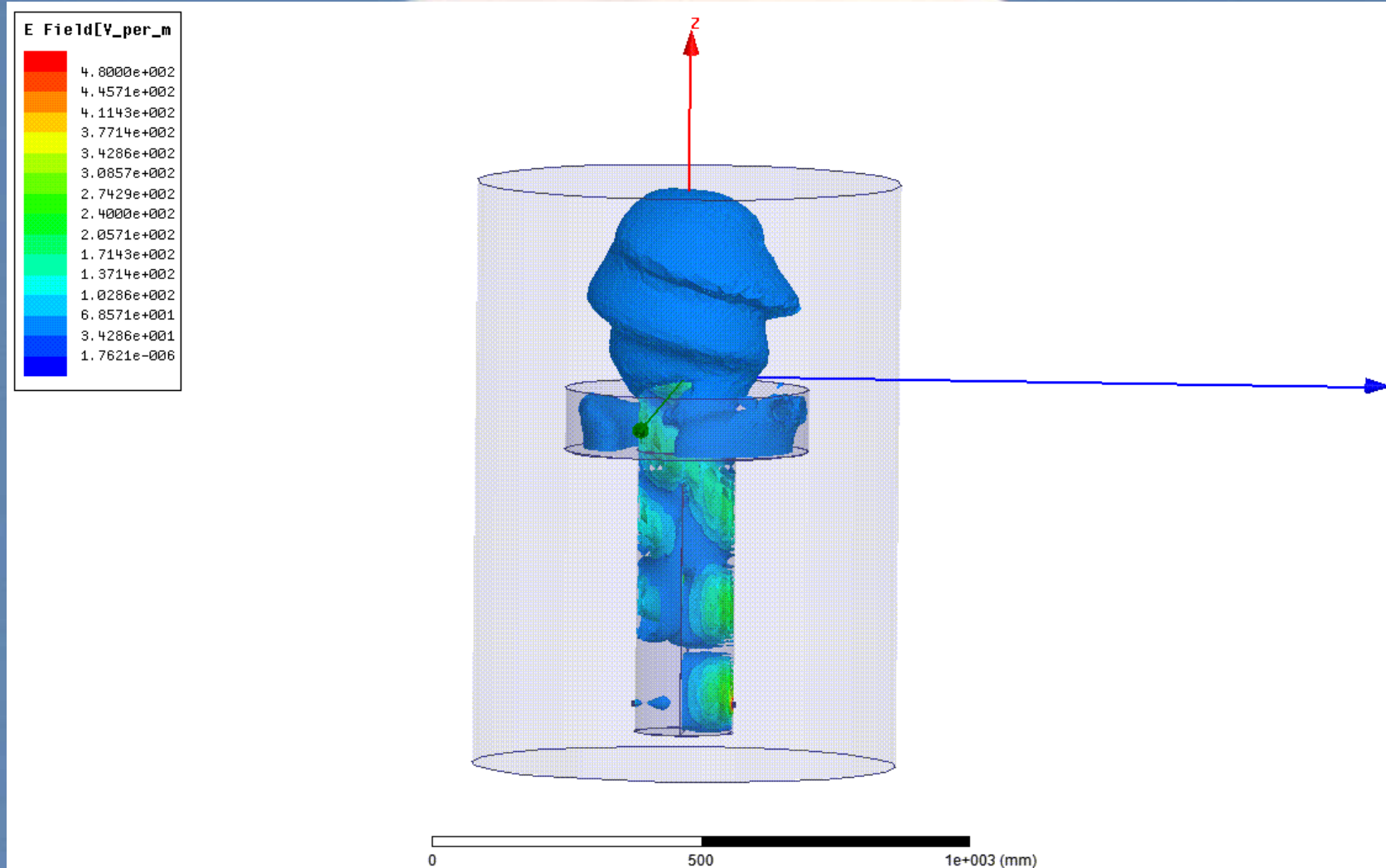

Feed without choke

- No beam shaping in Co-pol
- High Cross-pol level in 180 deg
- Mediocre efficiency
- High noise temperature

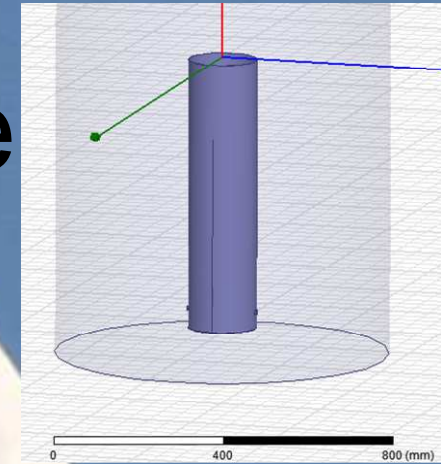

SM6FHZ 23 cm Septum feed w/o choke

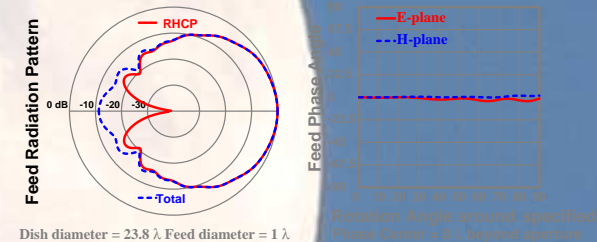

Dish diameter = 23.8 λ Feed diameter = 1 λ

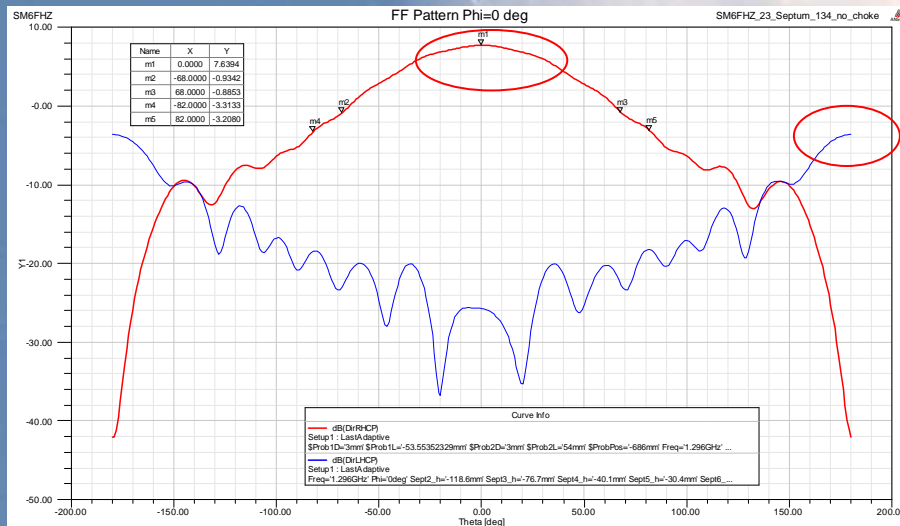
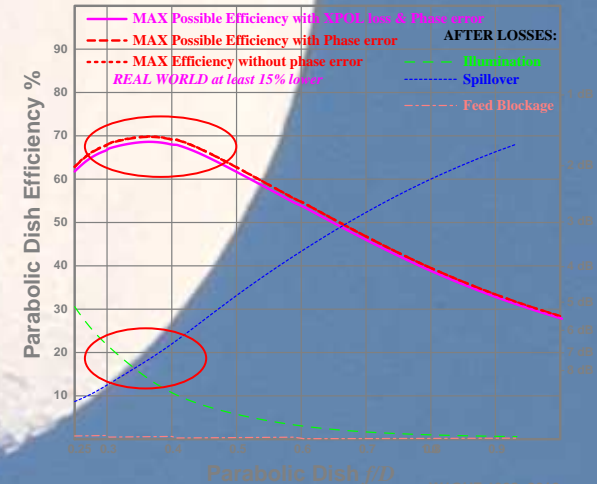

Why a Kumar choke?

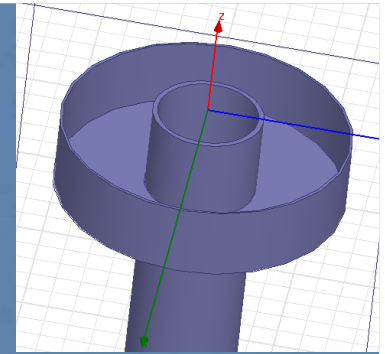

- The Kumar choke is a efficient yet simple way of shaping the radiation pattern of the feed.
- It was first described by Dr. A. Kumar [Reduce Cross-Polarization In Reflector-Type Antennas, Microwaves, March 1978] and has been used by VE4MA in his feed designs.
- It has some limitations and interactions with the other parts of the feed.
 - The Axial Ratio at angular offsets from bore sight is controlled by the choke
 - The Return Loss and Isolation is not affected by the choke
 - The radiation pattern can be controlled by the position and the size of the choke
- Less elaborate than the Scalar choke but comparable or superior performance
- It can be optimized using EM-simulation SW.

Septum - choke interaction

- Axial ratio optimization

- The septum sets the Axial Ratio at bore sight and the choke governs the performance at angular off-sets from bore sight
- The choke does not change the axial ratio at bore sight very much

- A well functioning septum is essential for getting a decent axial ratio also off bore sight

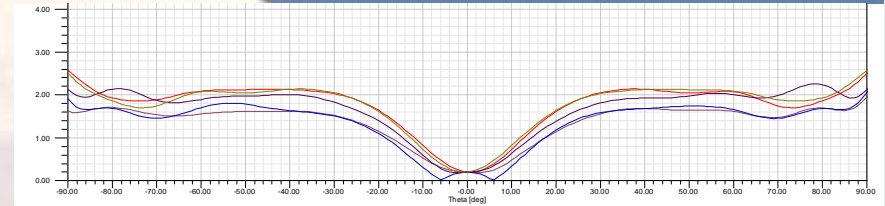

Choke impact on radiating pattern

- There is a contradiction between the wanted amplitude pattern and the phase error with respect to illumination angle
- By adjusting the choke position and dimensions you can find the best compromise
- **Moving the choke with respect to the W/G mouth does not directly scale the feed pattern for other f/D's. This is a myth! There is a price to pay.**
- The best way to strive for optimal performance at other f/D's is to change the dimension of the W/G mouth and hence the radiation pattern
- There are limitations on how much you can change the dimension of the W/G while maintaining the same W/G propagation mode
- W2IMU uses this in his "Dual Mode Feed" going to a higher mode as well as the first mode in the outer WG-section in an controlled way



Alternatives to the septum polarizer

A short, limited comparison with
the “squeezed W/G” polarizer

Squeezed WG circular polarization feeds

- Feed main dimensions from SM6FHZ Kumar feed
- Polarizer dimensions start values from CT1DMK Dubus paper (and web page description)
- Polarizer dimensions optimized for this particular feed
- Some optimization work still could be done on the feeds

Model of the 3cm feed

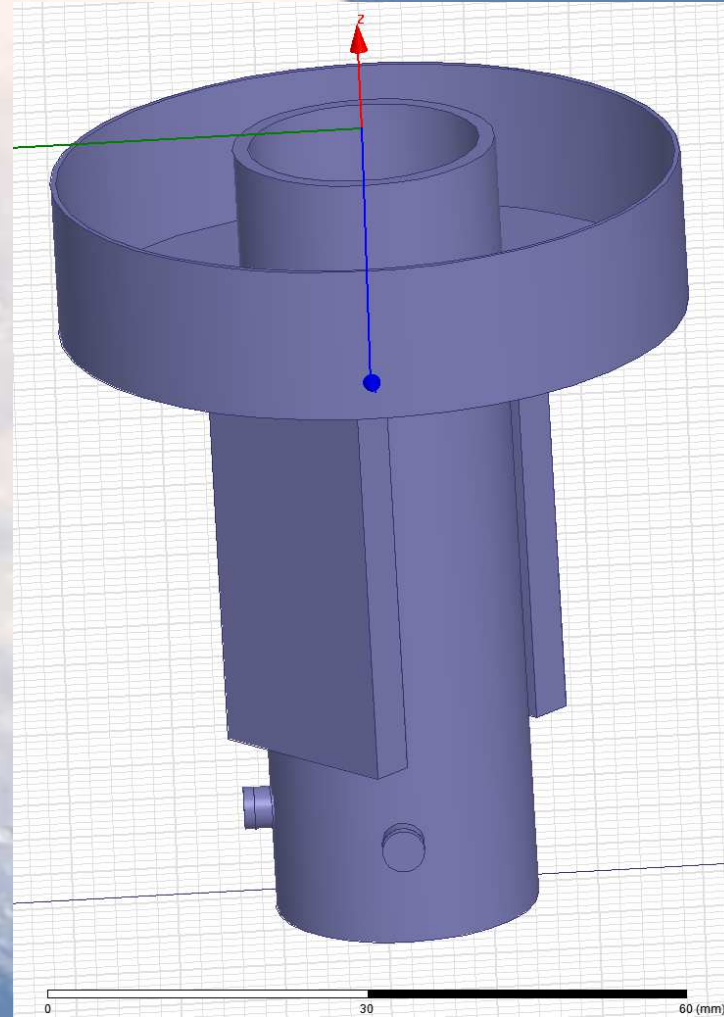
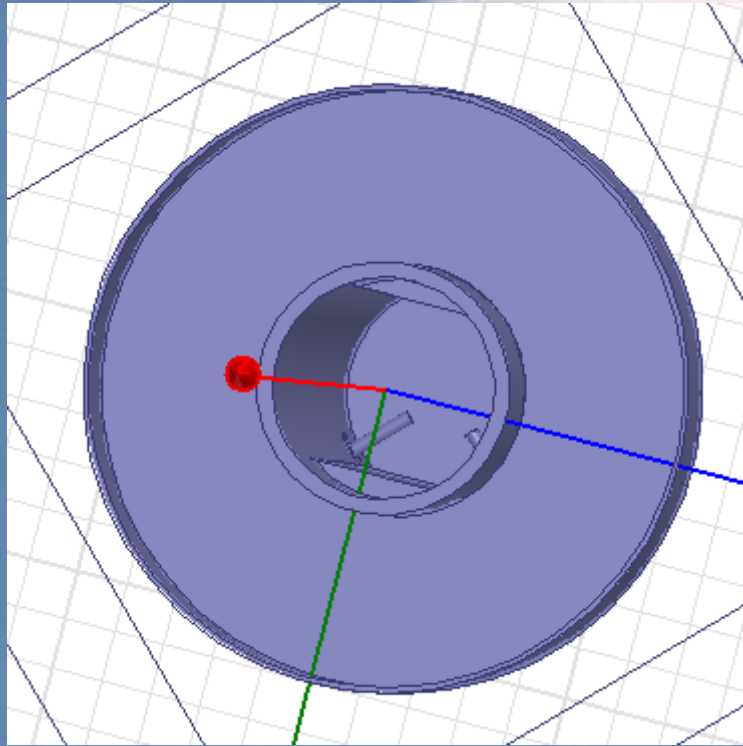

S11, S22 and S21

SM6FHZ

S11, S22 & S21 combined

SM6FHZ_0795wl_3cm_Squeeze_feed1

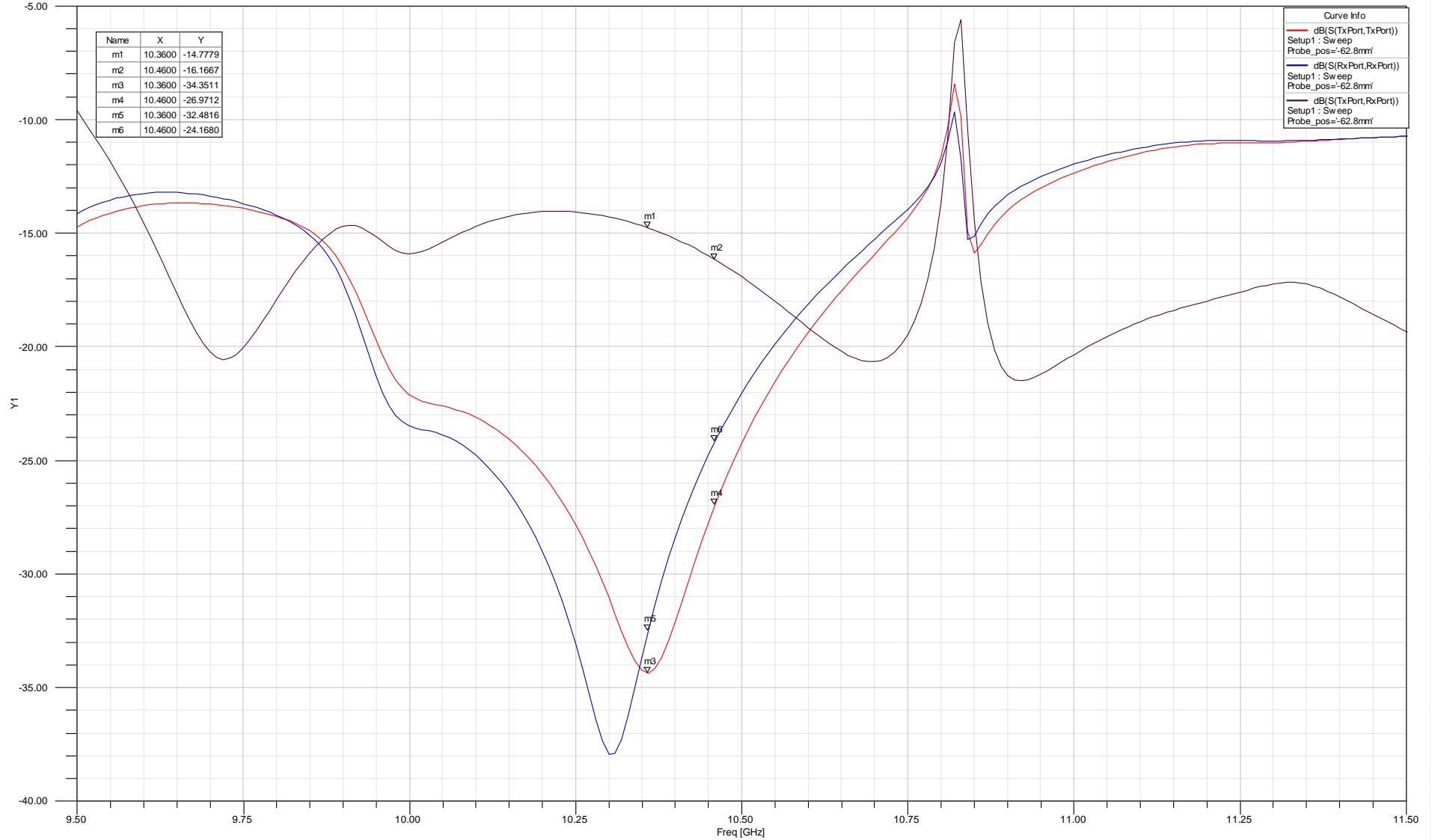

Far Field pattern Phi=90 deg

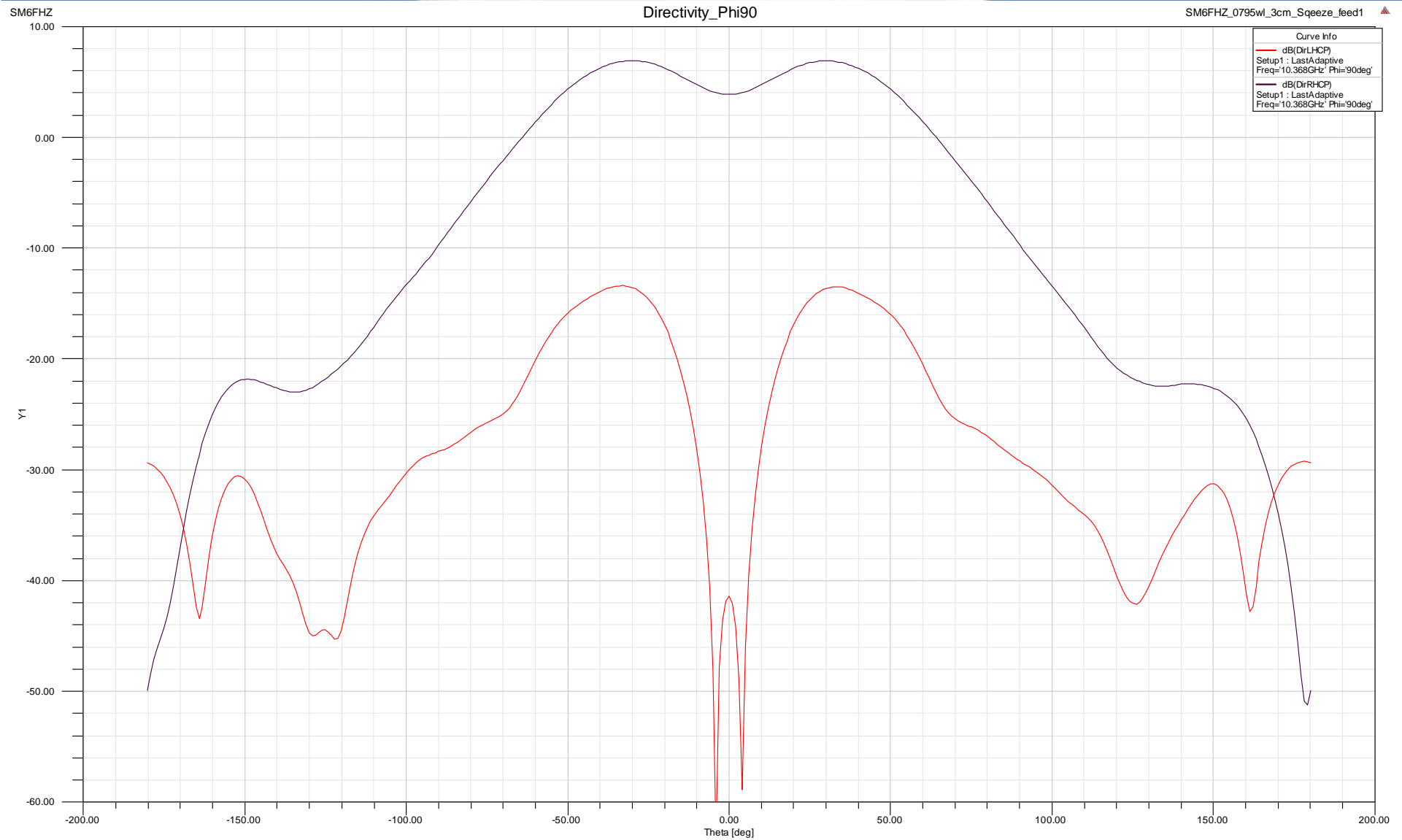

Axial Ratio

SM6FHZ

AxialRatio

SM6FHZ_0795wl_3cm_Squeeze_feed1 ▲

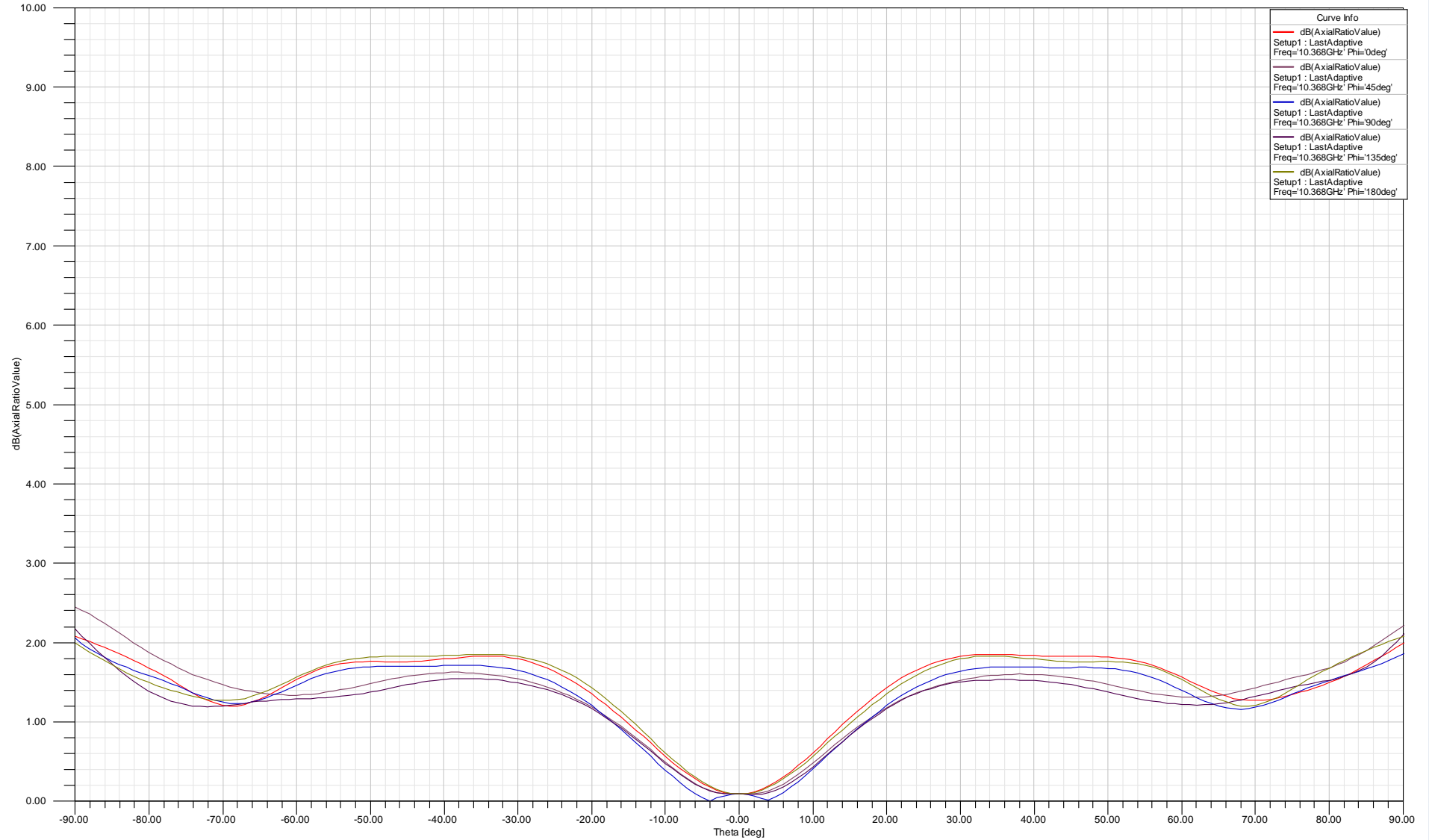

Model of the 6cm feed

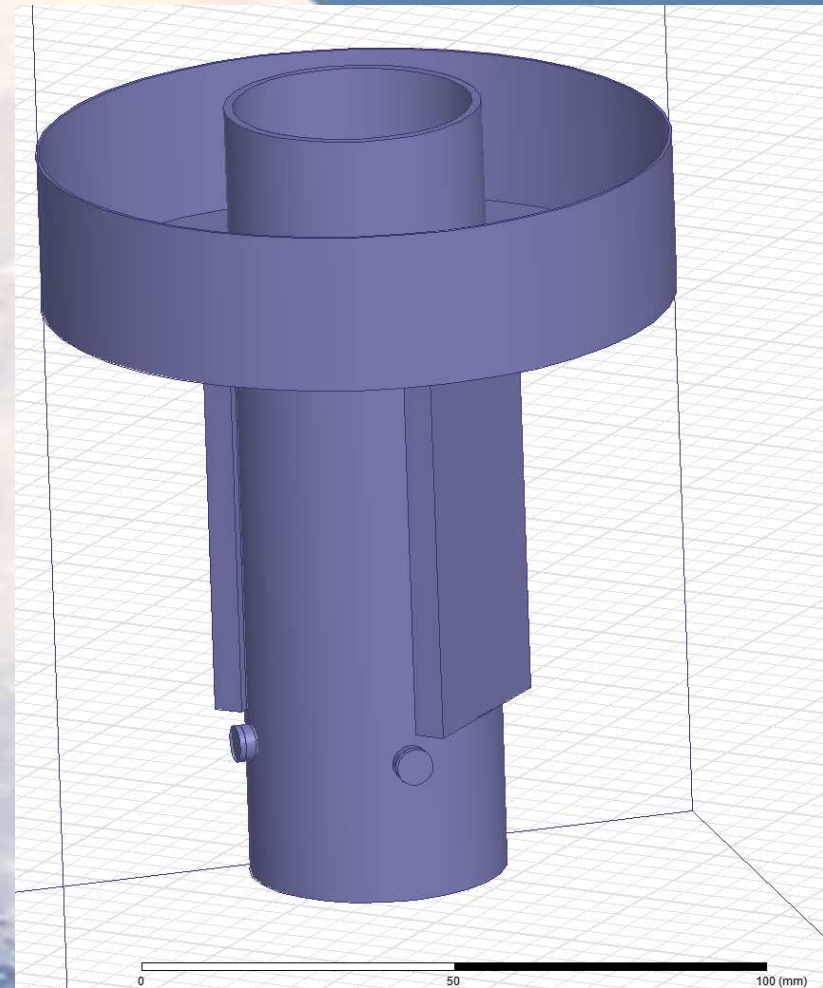
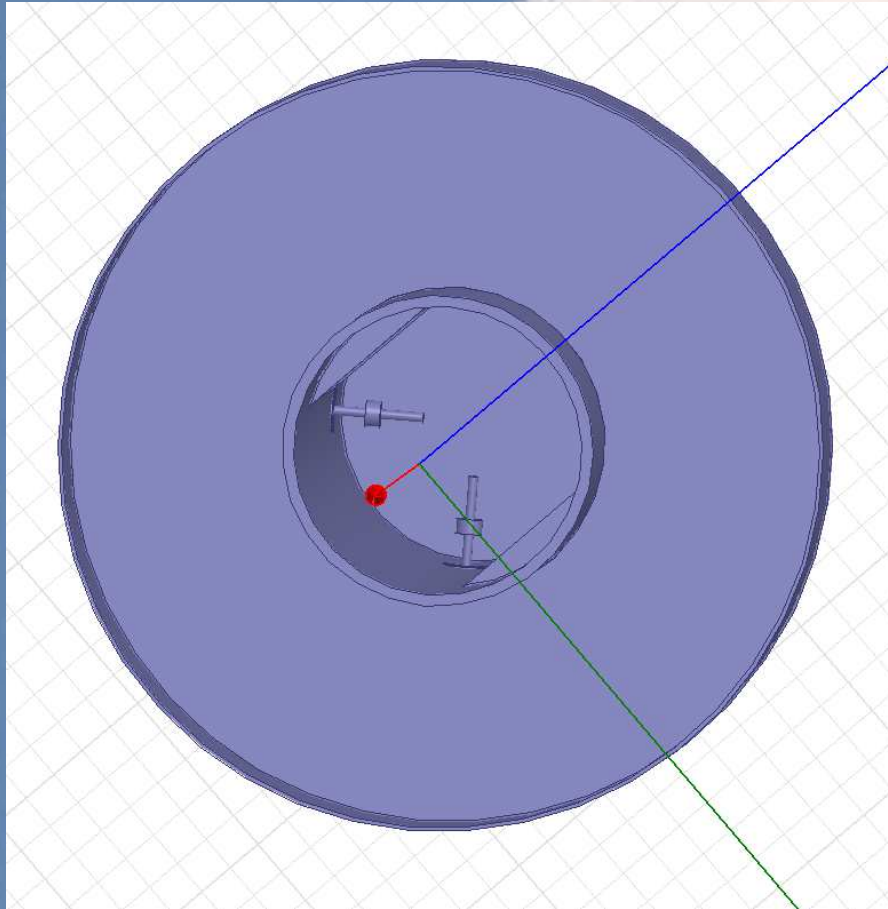

S11, S22 and S21

SM6FHZ

S11, S22 and S21

SM6FHZ_Kumar_feed_squeeze_pol3 ▲

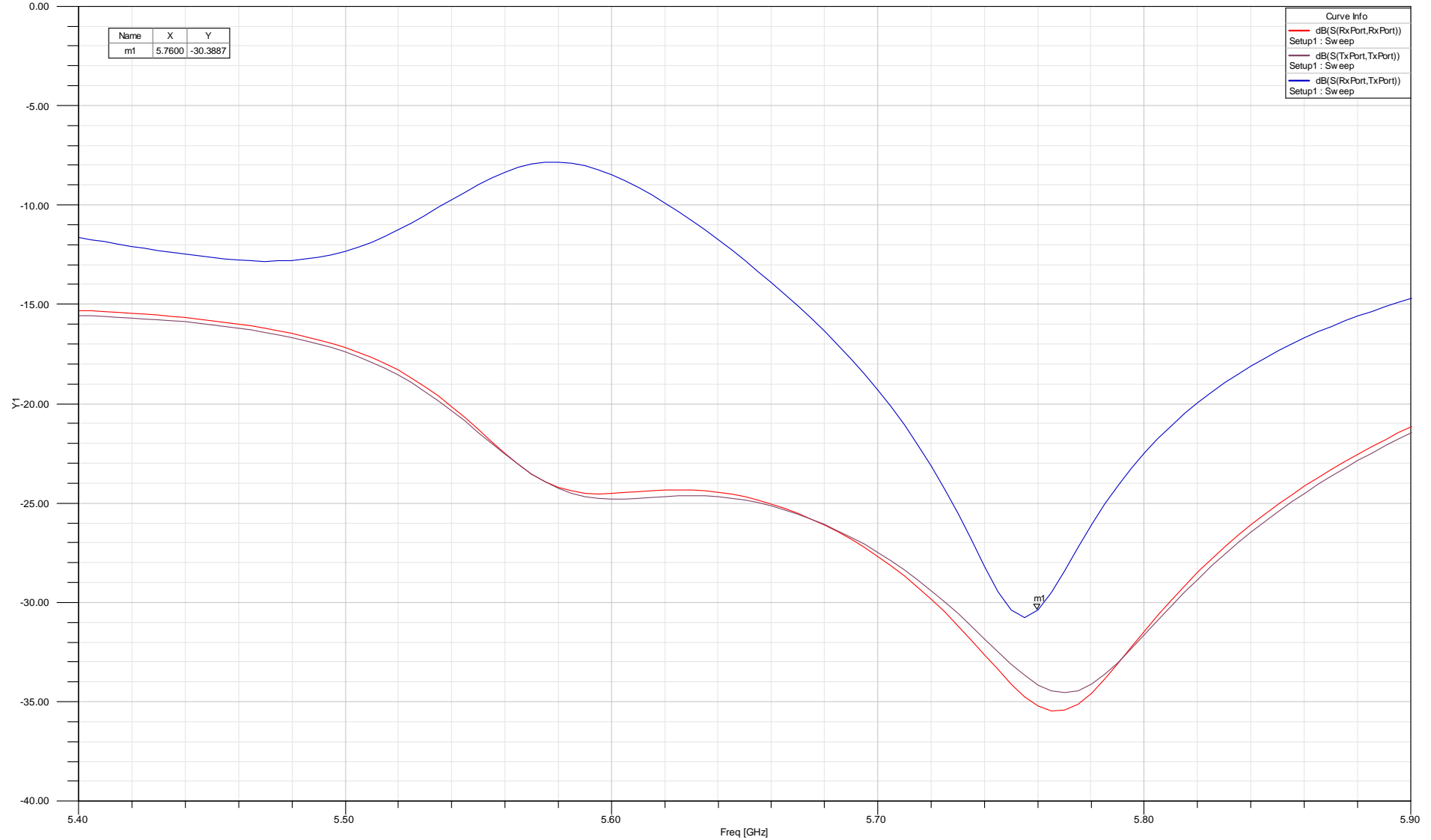

Far Field pattern Phi=90 deg

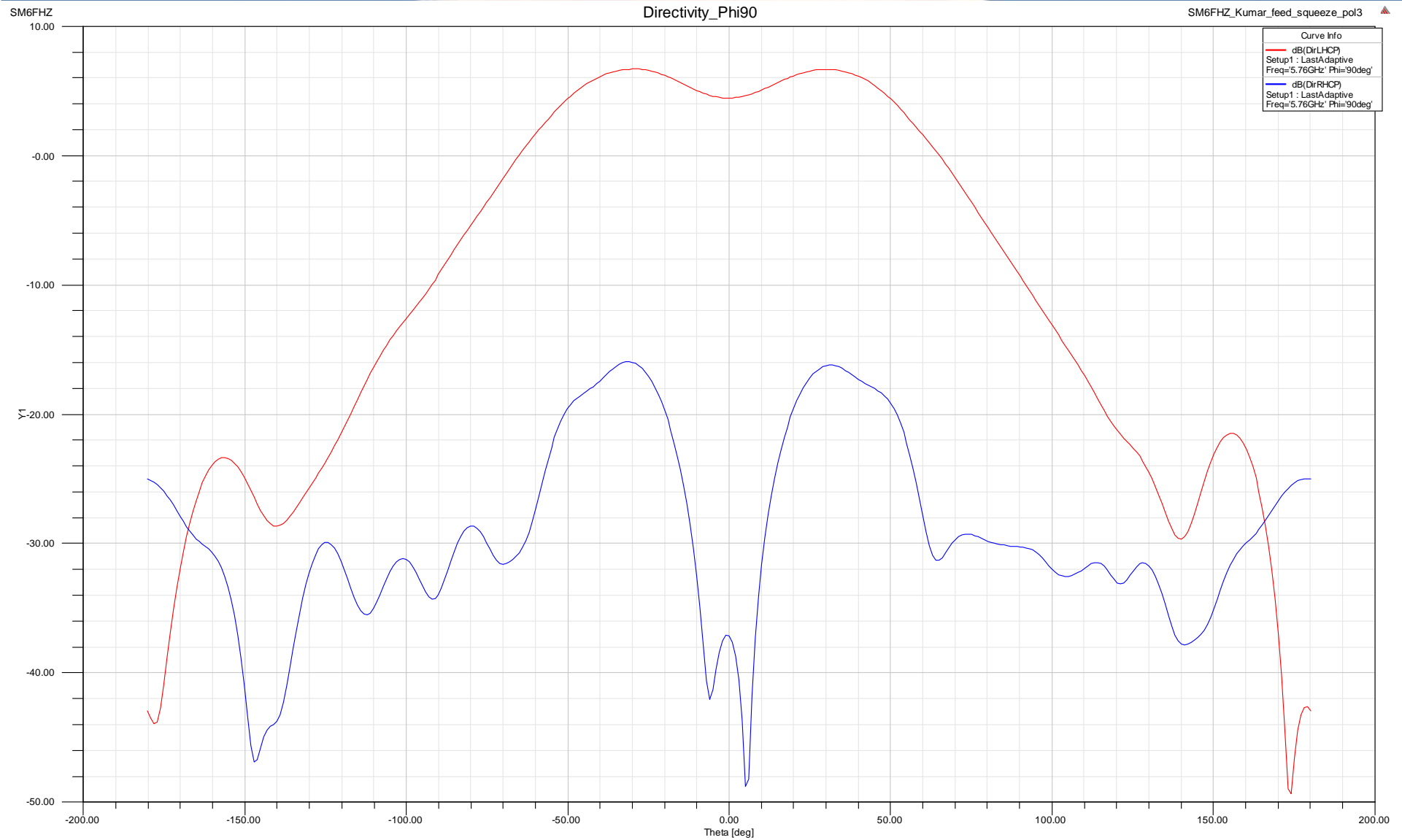

Axial Ratio

SM6FHZ

AxialRatio

SM6FHZ_Kumar_feed_squeeze_pol3 ▲

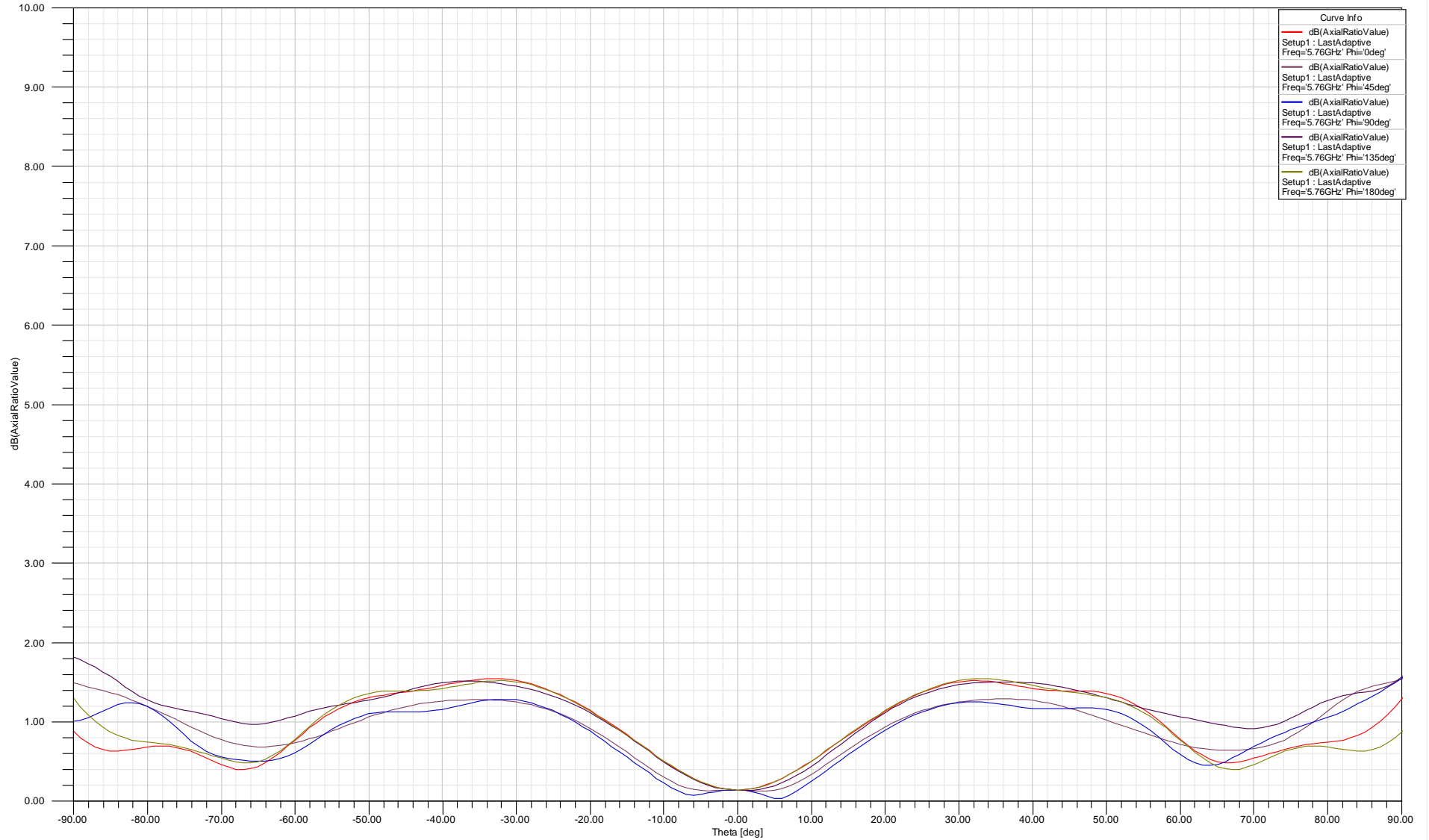

Conclusions Squeezed Polarizer

- Performance very similar to the SM6FHZ Kumar Septum feed
- The squeezed WG polarizer is sensitive to the intrusion depth of the squeeze. Has to be within $<0.05\text{mm}$ in order to get full performance. The septum design seems to be less critical, even if it is quite critical on 10 GHz as well
- It is more or less up to the builder to choose what he seems to be the easiest one to build



Theory and simulations versus “reality”

Can we rely on EM-simulation results?

Simulation validity / accuracy



- Simulations versus measurements analysis
- 5.7 GHz feed example
- S-parameters measured on a professional network analyzer
- Radiating parameters measured on a professional far field antenna measurement range
- Results analyzed and presented in Matlab using dedicated scripts

Simulated S-parameters

SM6FHZ

S11, S22 and S21 combined

SM6FHZ_septum_feed_w_choke_42_22

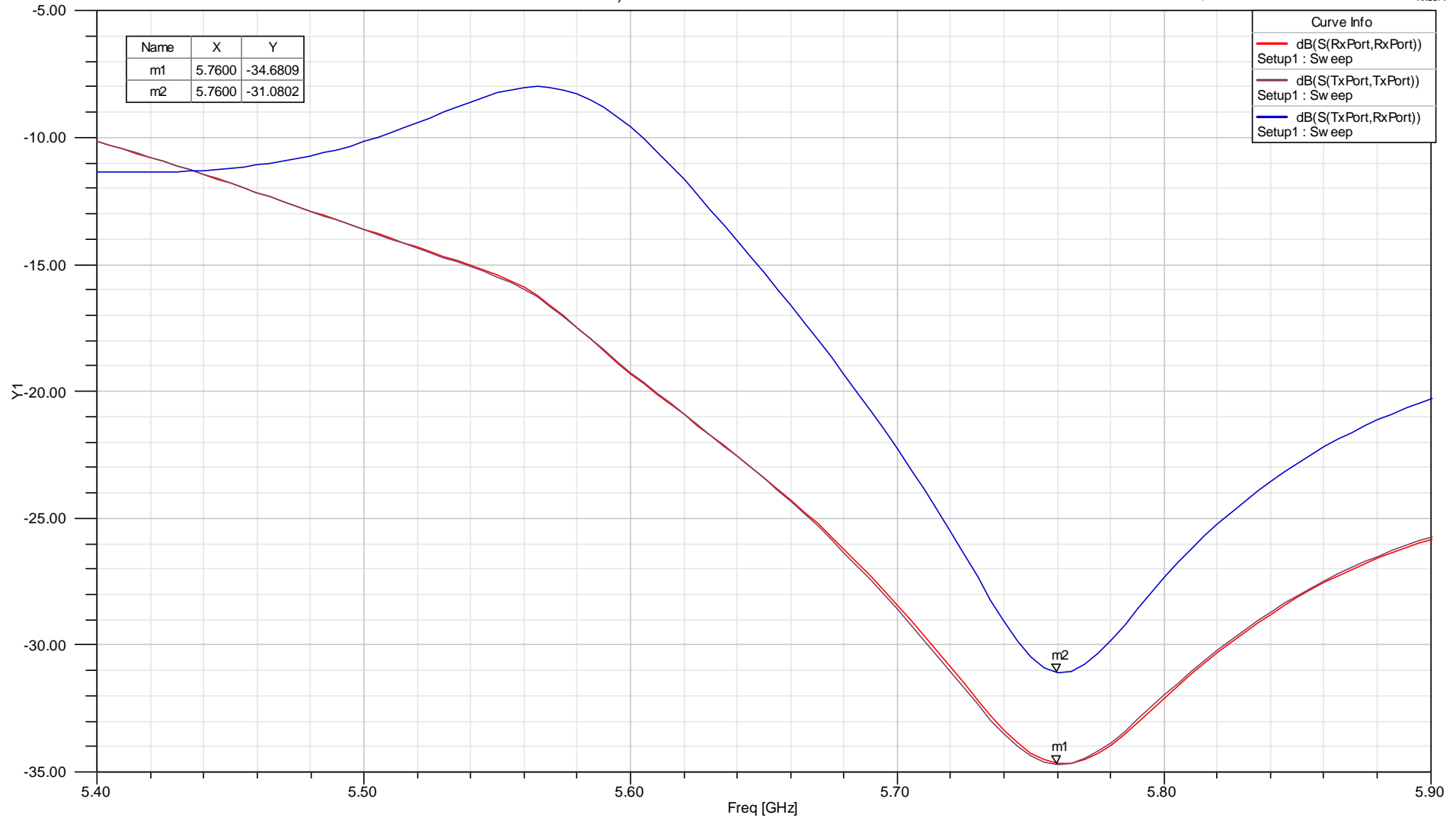

Measured S-parameters

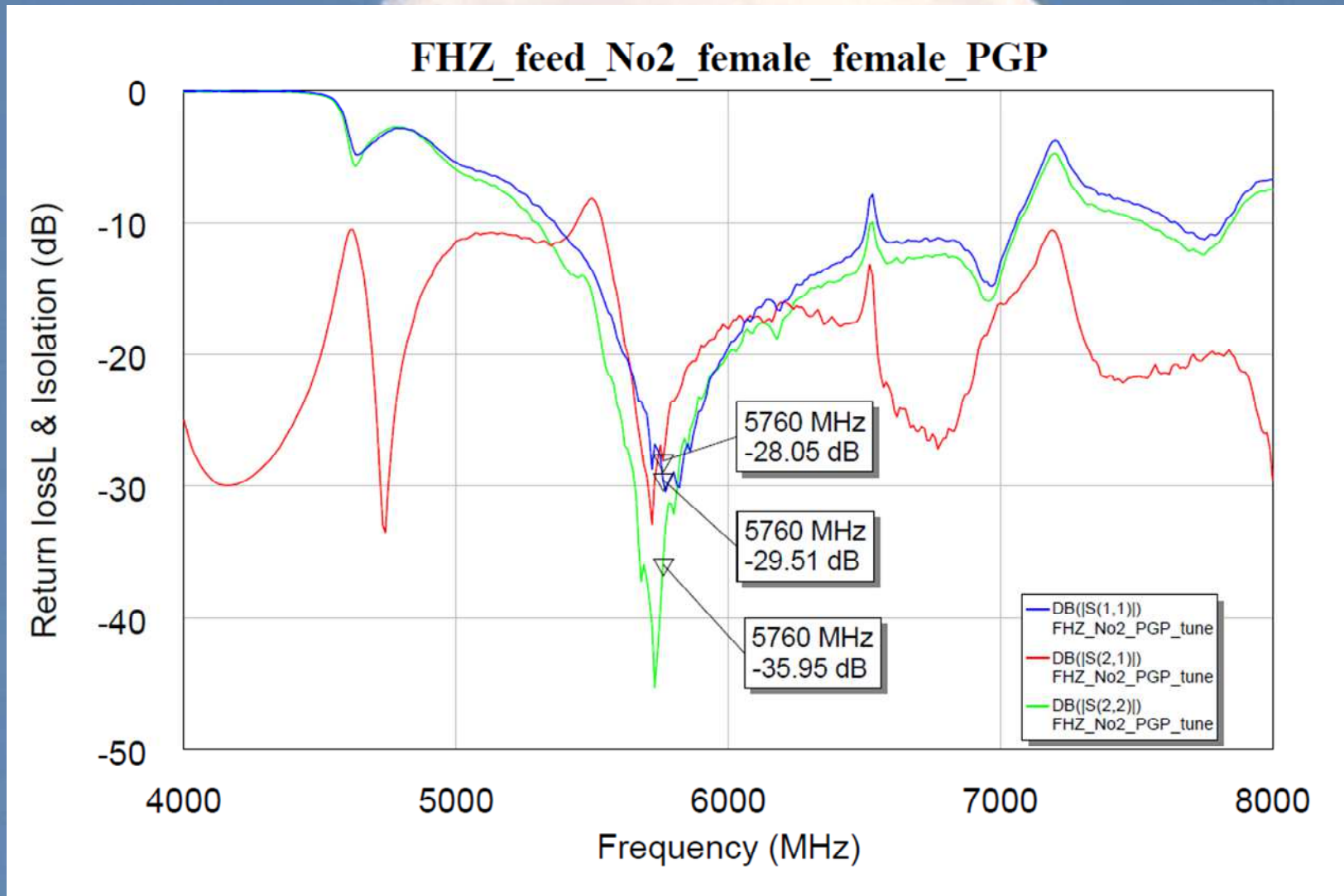

Far Field pattern performance comparison, measured vs. simulated for $\Phi=-90$ deg

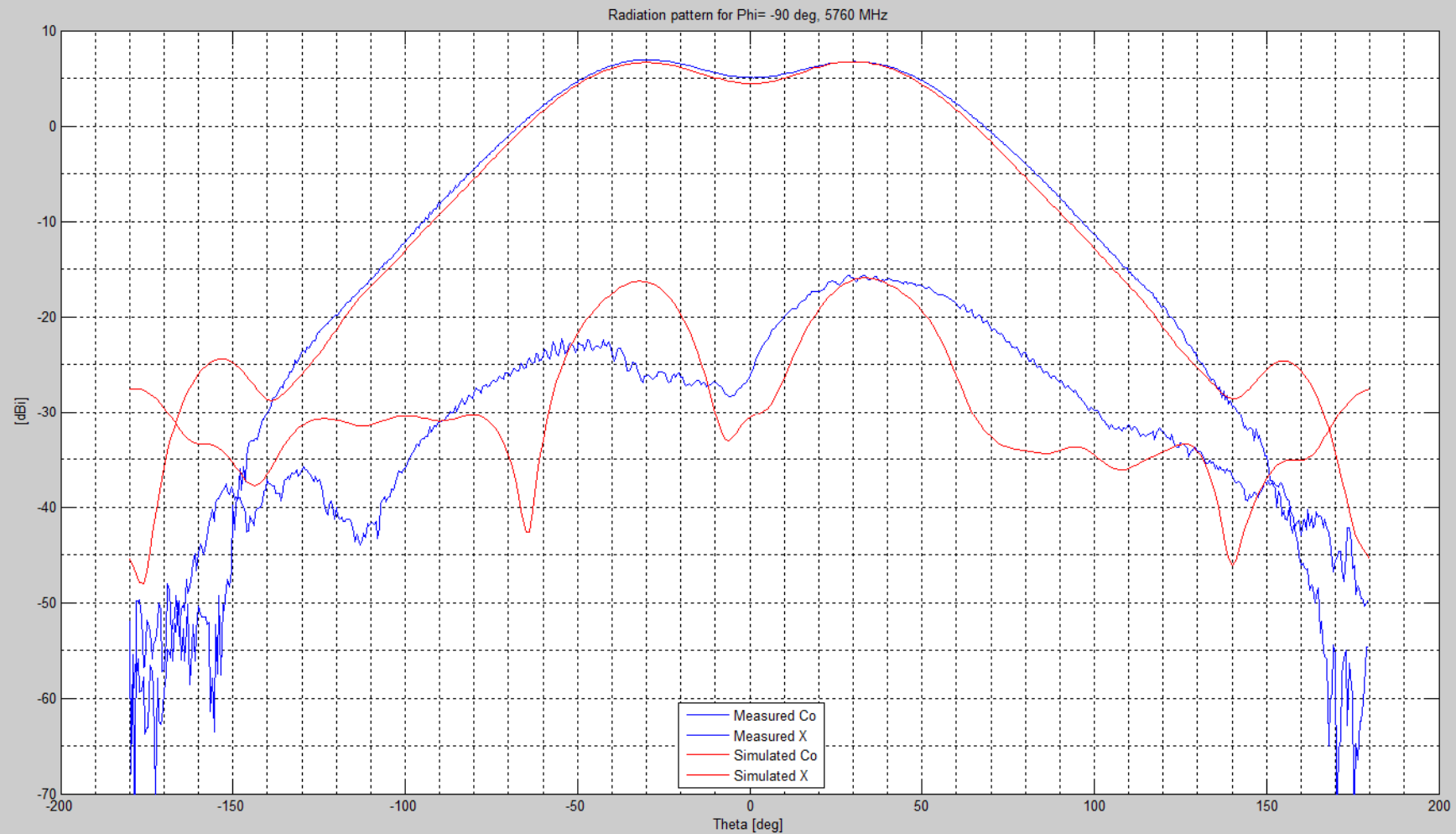

Conclusions from measurements

- Very good agreement between simulations and measurements. Well within the expected accuracy's of both simulations and measurements.
- Most of the discrepancies can be explained by the differences in the environment in the simulations and the measurements
- The 5.7 GHz measurements can serve as a guidance of the accuracy of the simulations on the other feeds presented in Örebro in 2013 / 2015 as well as other simulations done at feeds before and after that.
- The result also shows that it is possible to build the feeds with enough accuracy to preserve and achieve the performance predicted in the simulations
- This gives good confidence in using EM-simulation S/W to design high performance feeds and to judge the performance of feed descriptions that show up in different ham radio magazines.

Wave Guide interface

- Standard WR-90 wave guide interface towards user
- Resonant slot matching / coupling from WR-90 into the circular TE₁₁ wave guide in approximately the same position as the coaxial probe
- The dimensions and position of the slot all determines the matching into the TE₁₁ wave guide (slot length and width, wall thickness, distance to back wall, position in the WR-90 WG as well as the angle to the septum)
- The wave guide interface gives the same performance as the coaxial probe interface and is used in all configurations

Port definition

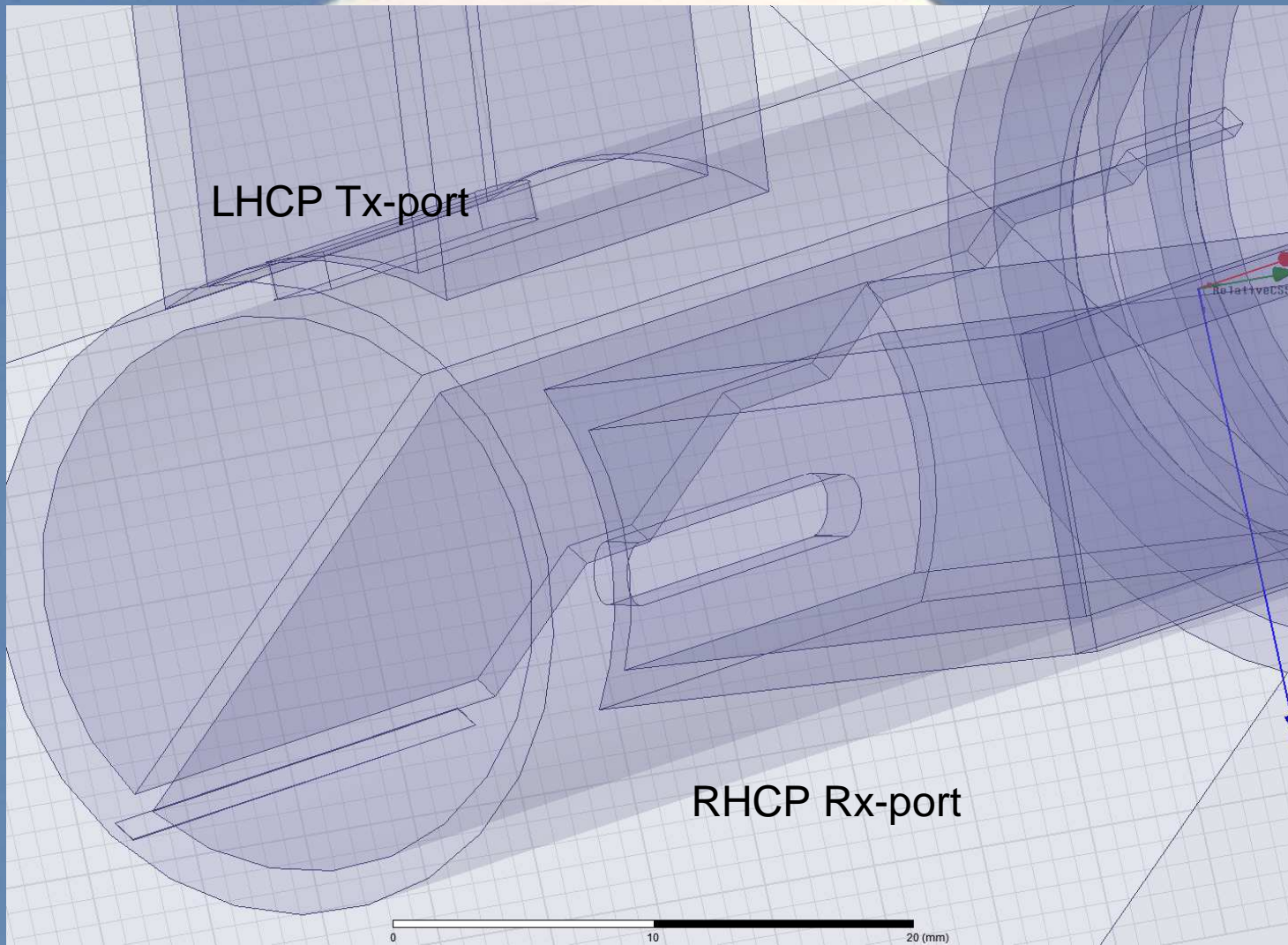

Port definition

Circular polarization convention
for EME according to Crawford
Hill Bulletin No 1:

Tx RHCP in space
Rx LHCP in space

Take polarization reversal into
account when using reflector
antennas.

LHCP Tx-port

RHCP Rx-port

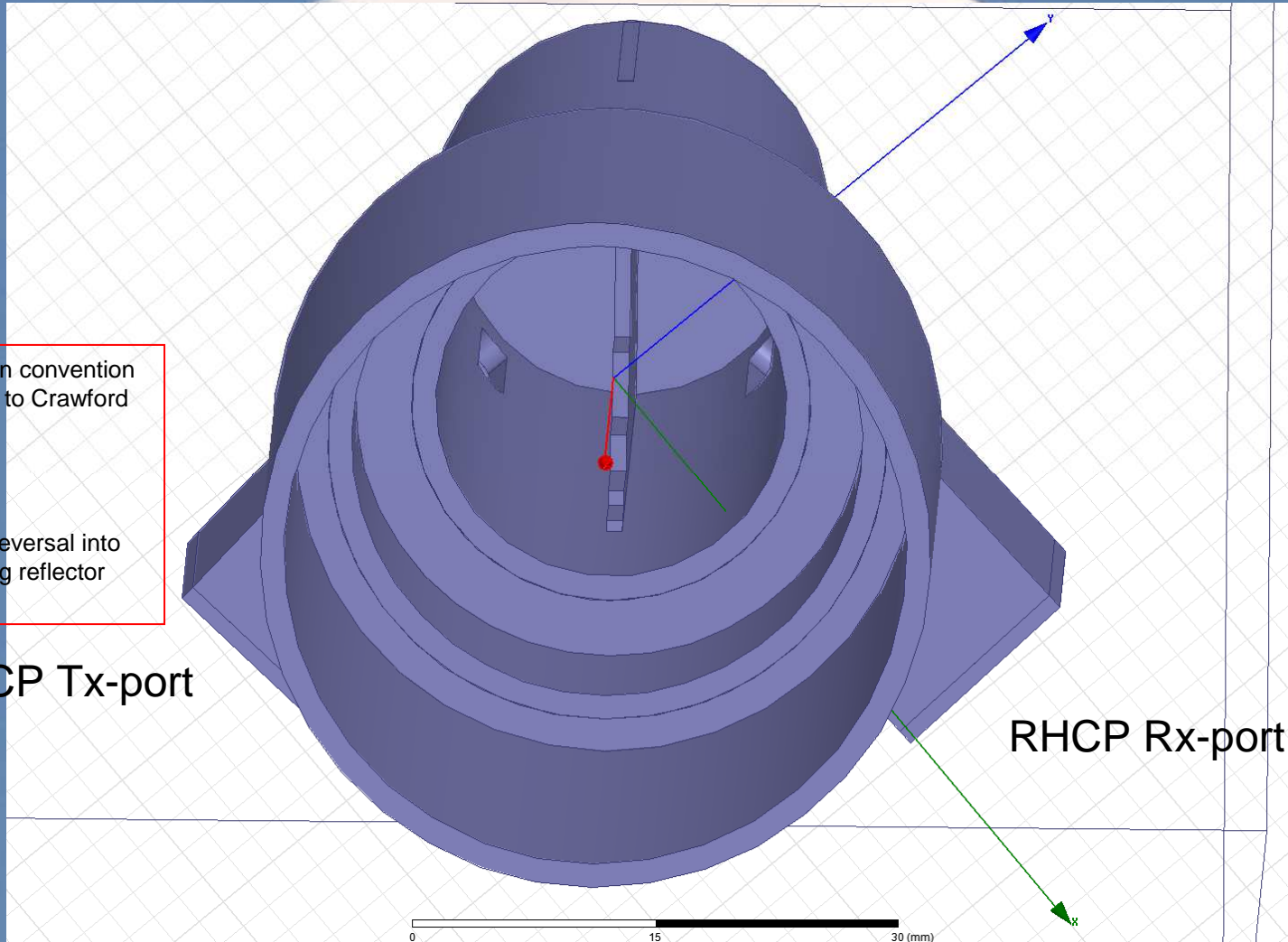

WG-interface and Slot dimensions

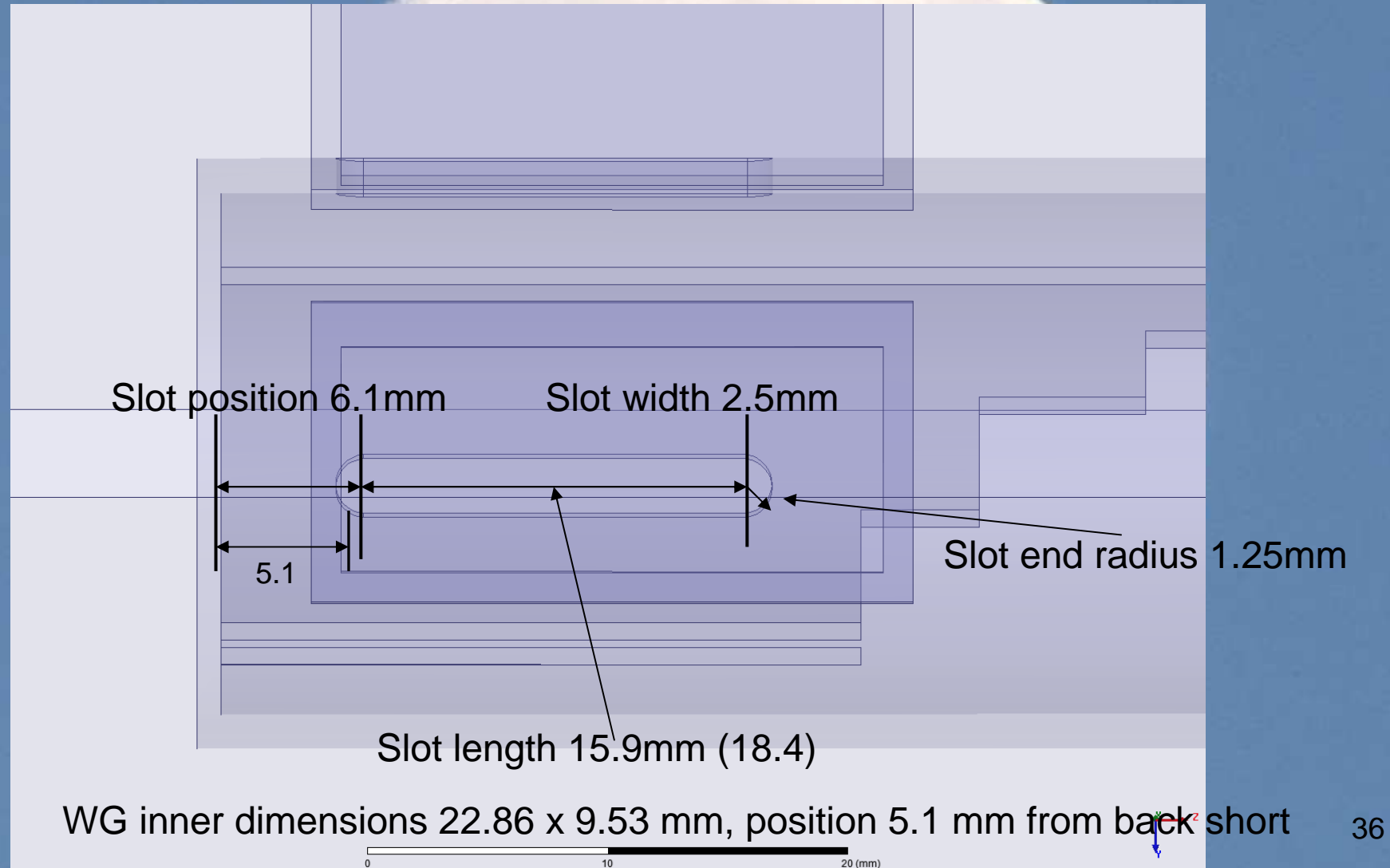

S11, S22, S21 combined

(3 cm WG interface metric and inch-based comparison)

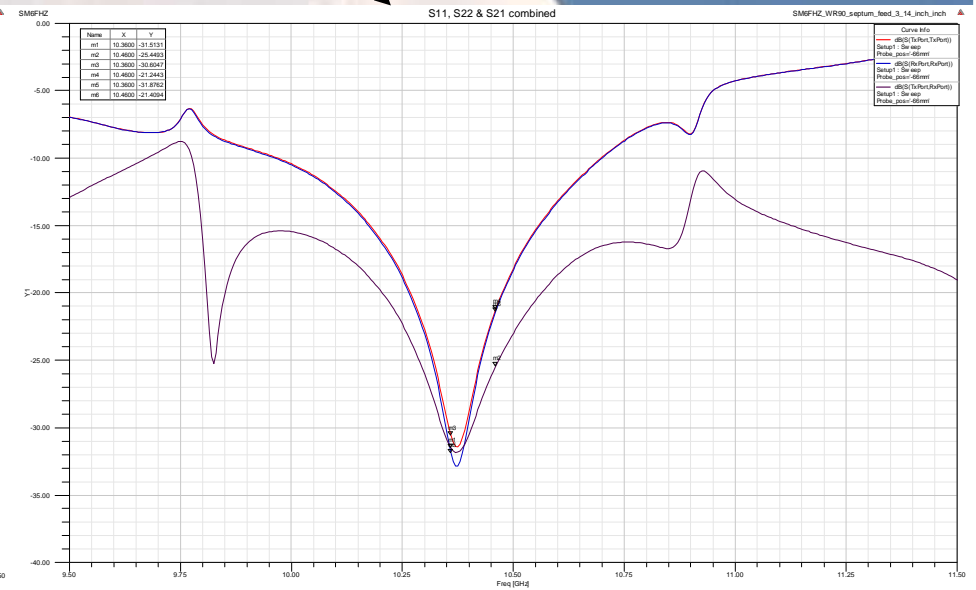
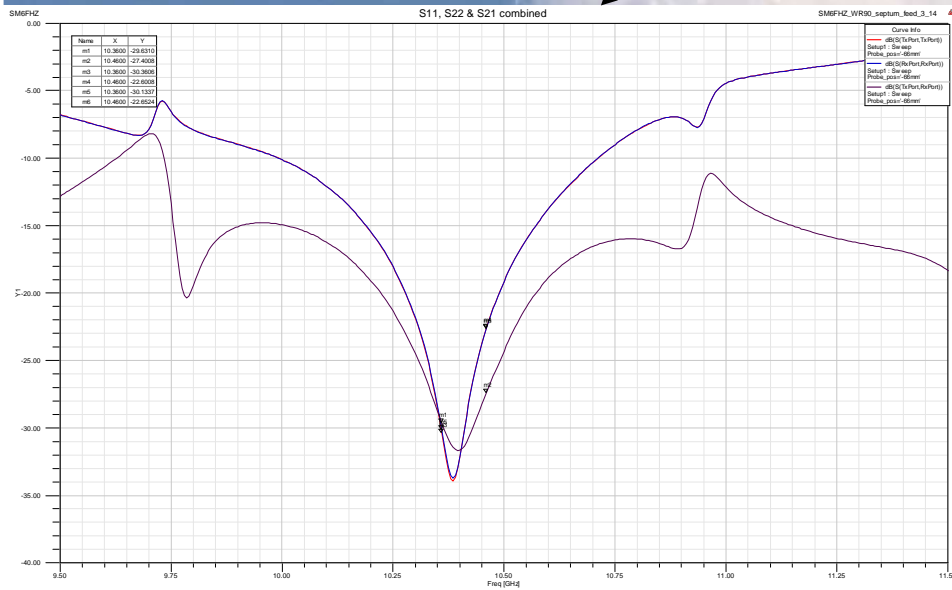

RHCP port (Rx)

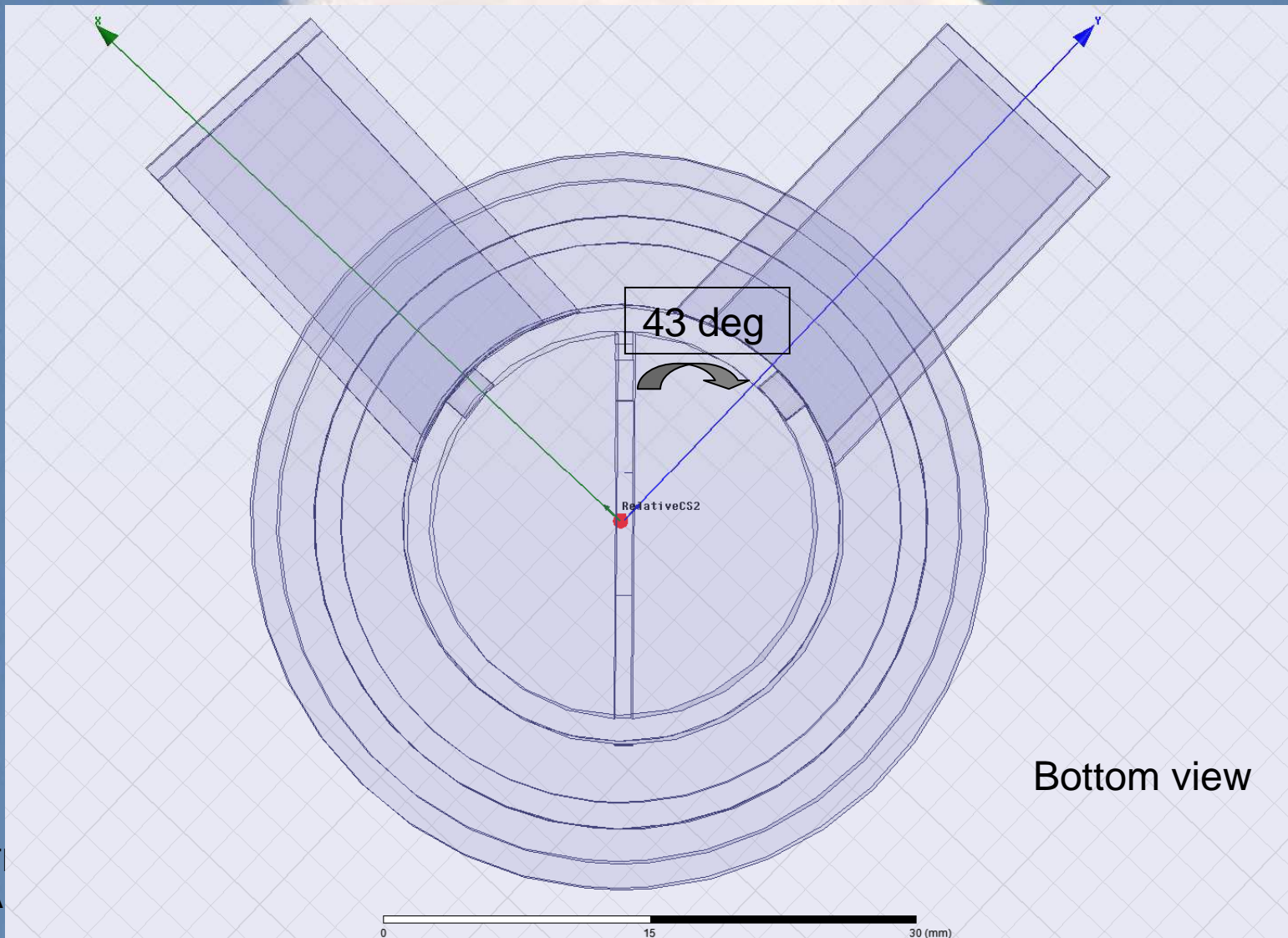

RHCP slot (Rx)

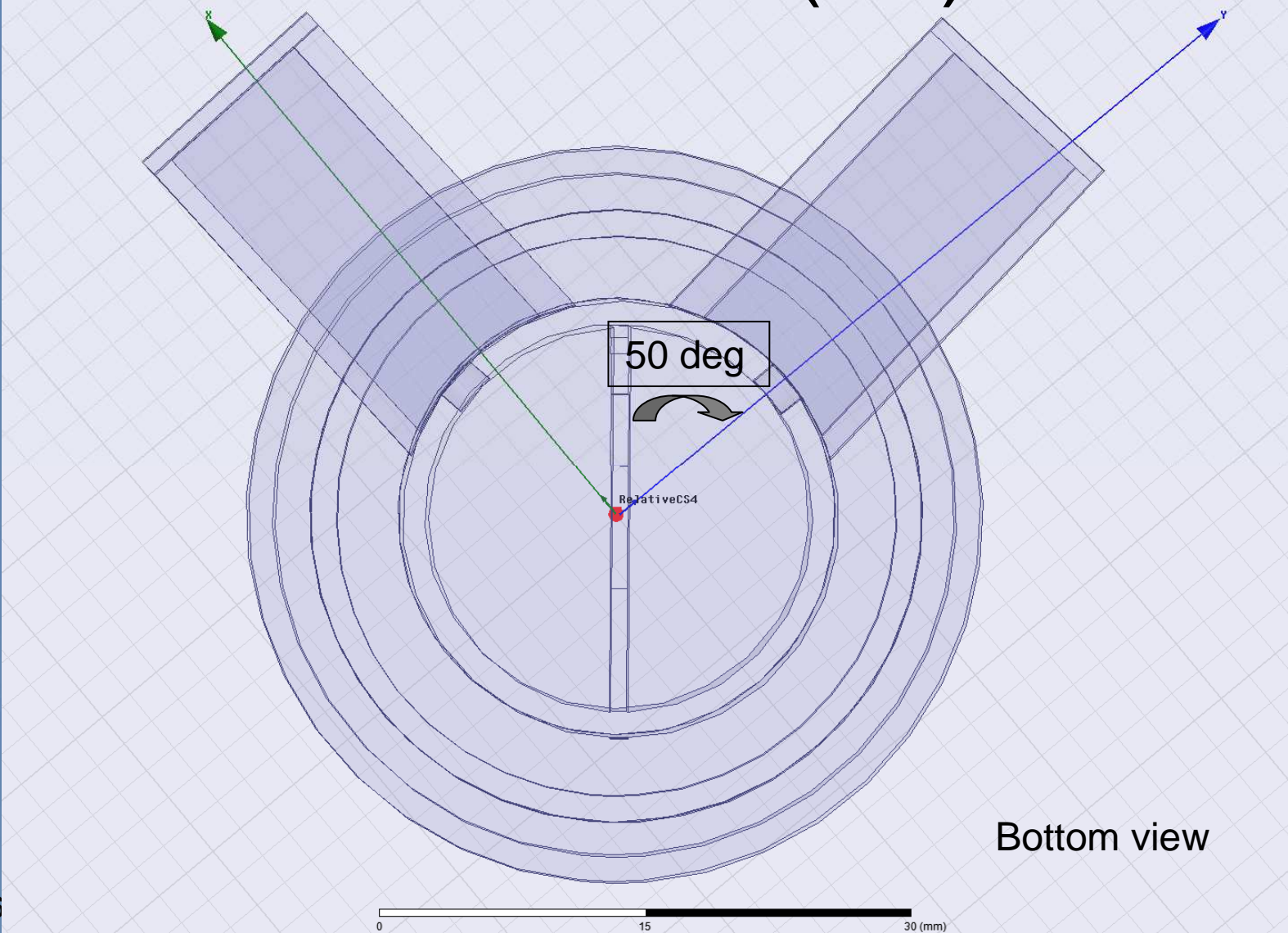

LHCP port (Tx)

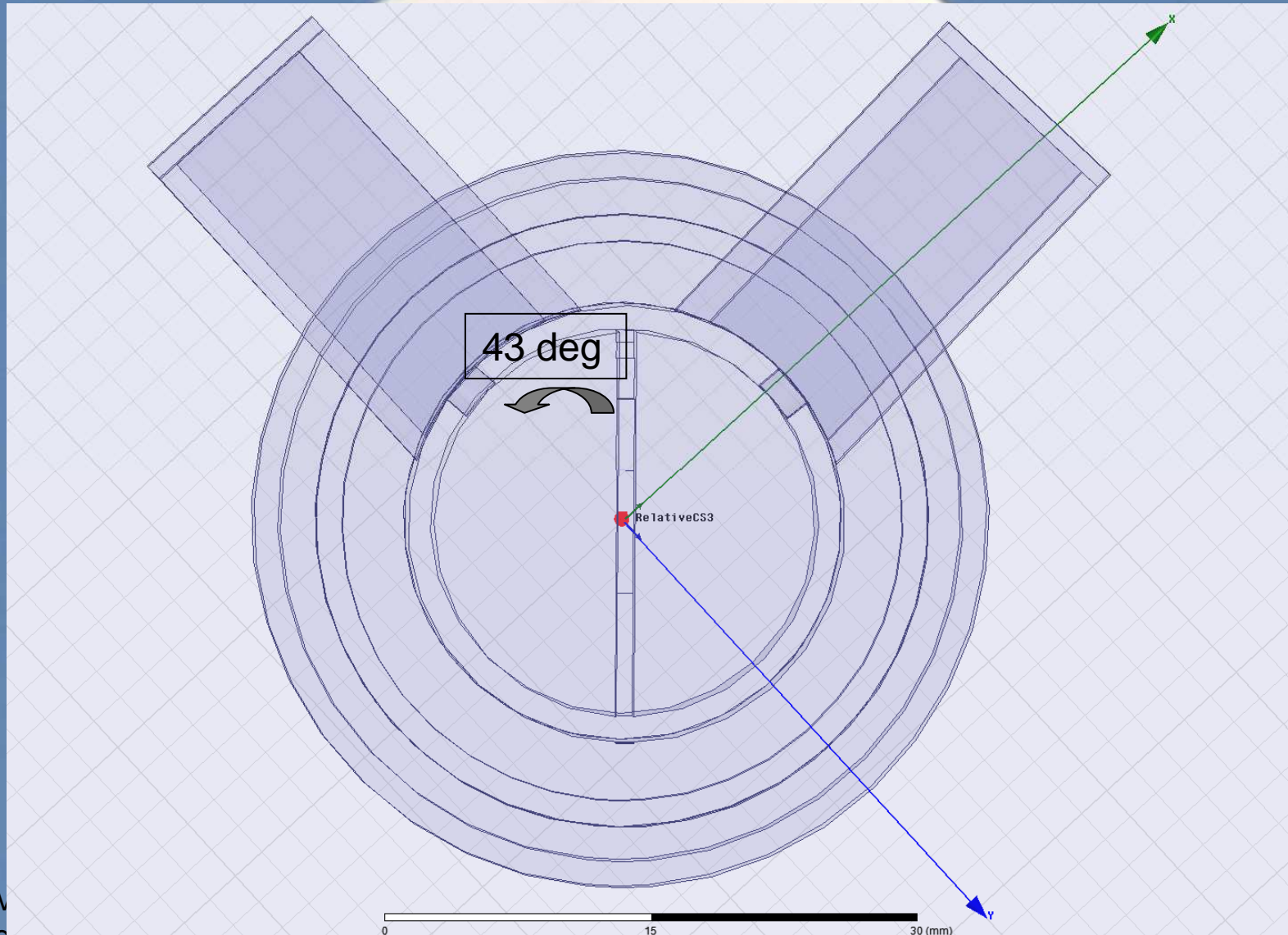

LHCP slot (Tx)

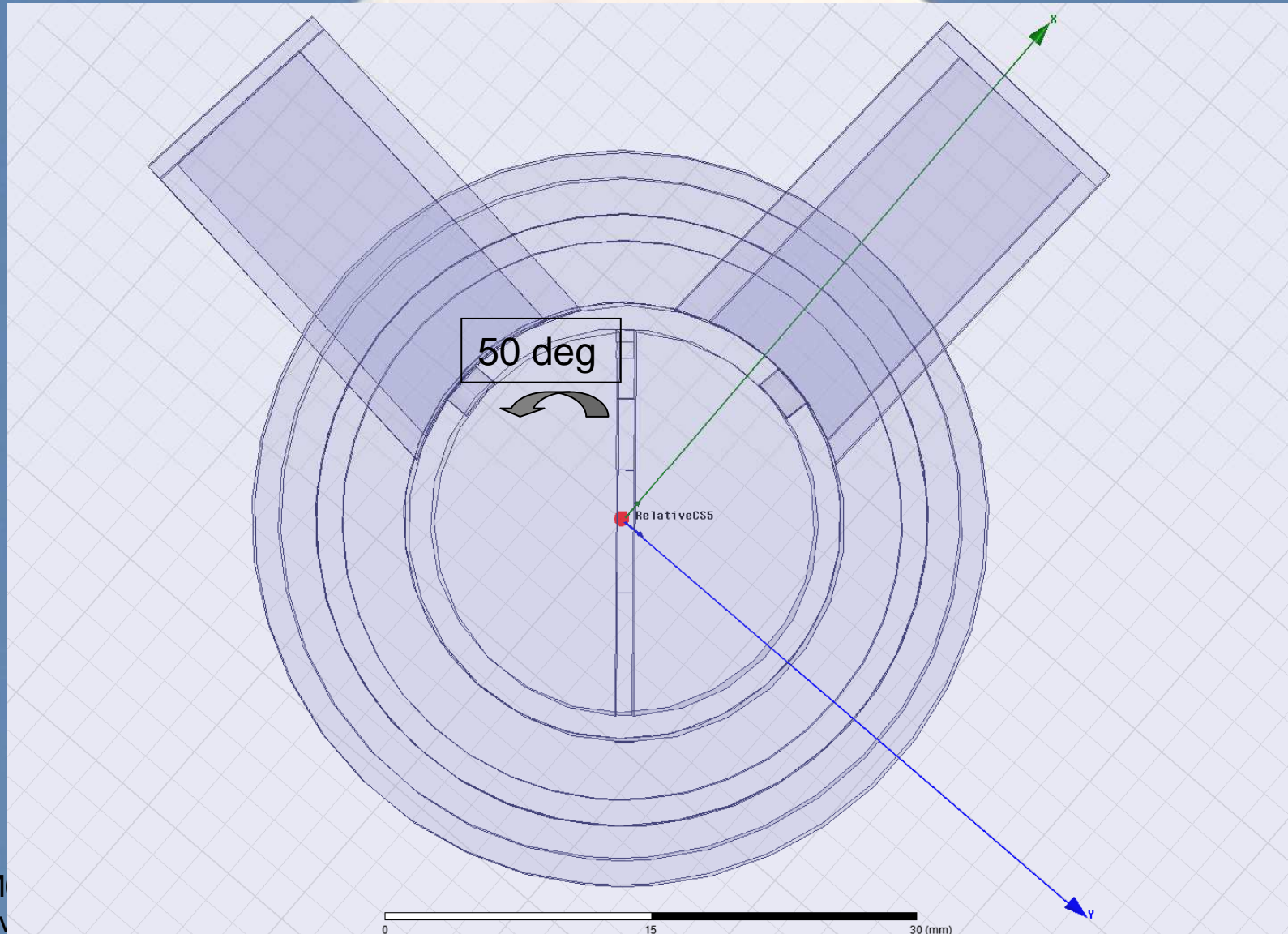

WG-dimensions

(3 cm 0.760 wl WG, Dual Mode 39mm)

Circular polarization convention for EME according to Crawford Hill Bulletin No 1:

Tx RHCP in space
Rx LHCP in space

Take polarization reversal into account when using reflector antennas.

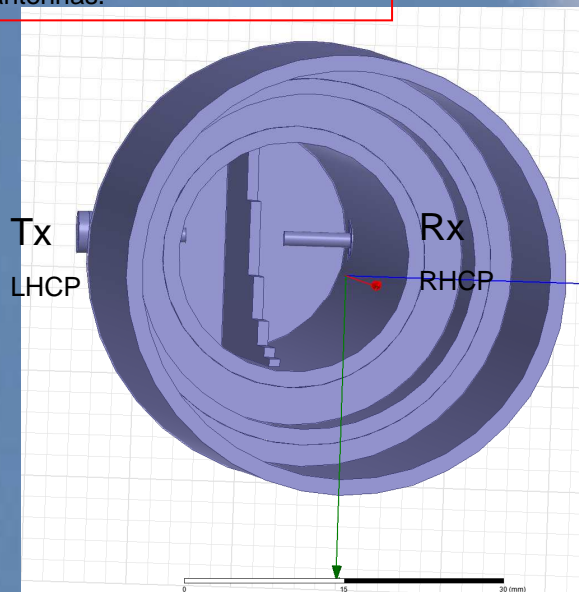

SM6FHZ 2015-05-26
Rev A

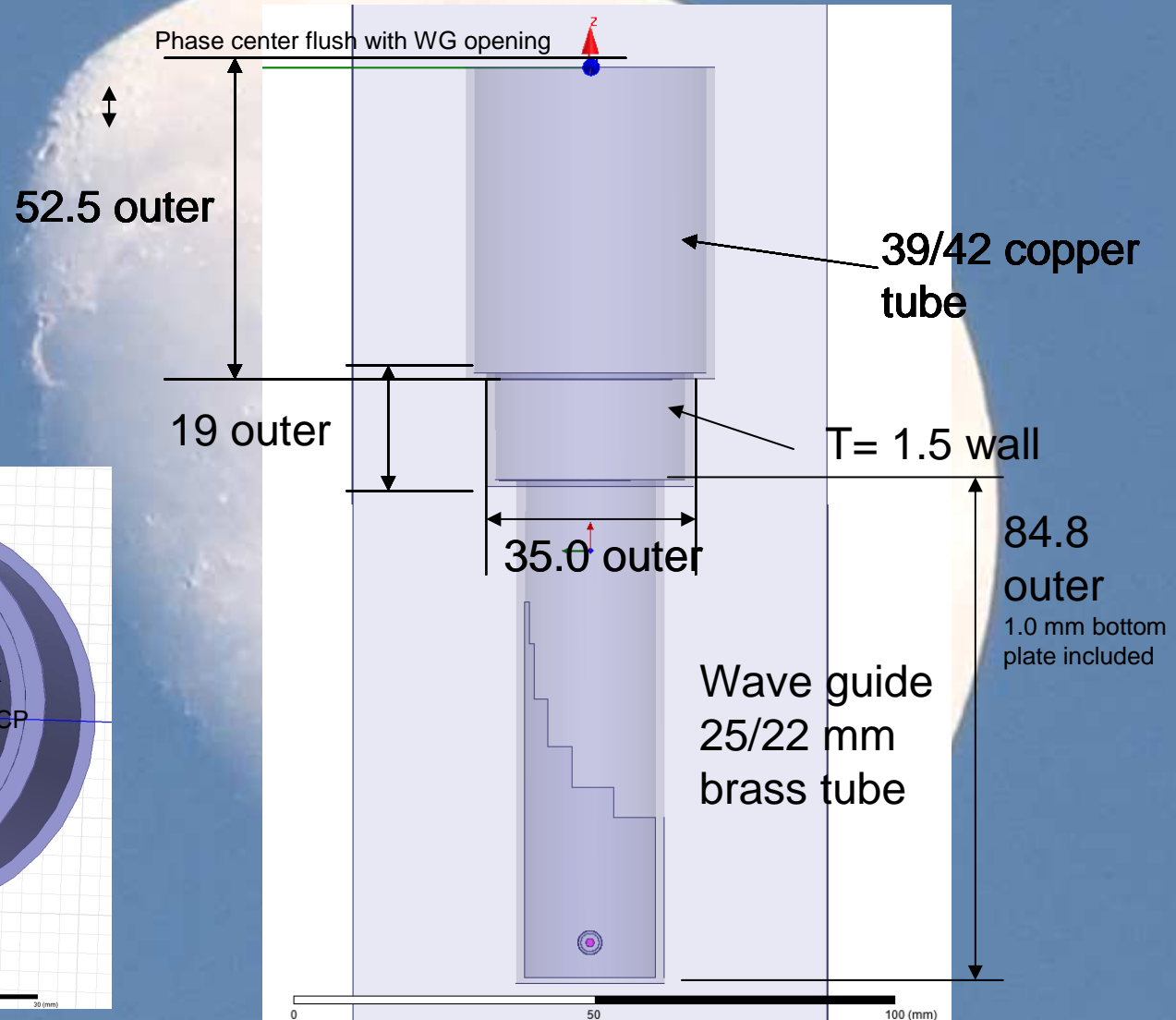

Swedish EME-meeting May 2015

Detail of WG / transformer and output section

(3 cm 0.760 wl WG, Dual Mode 39mm)

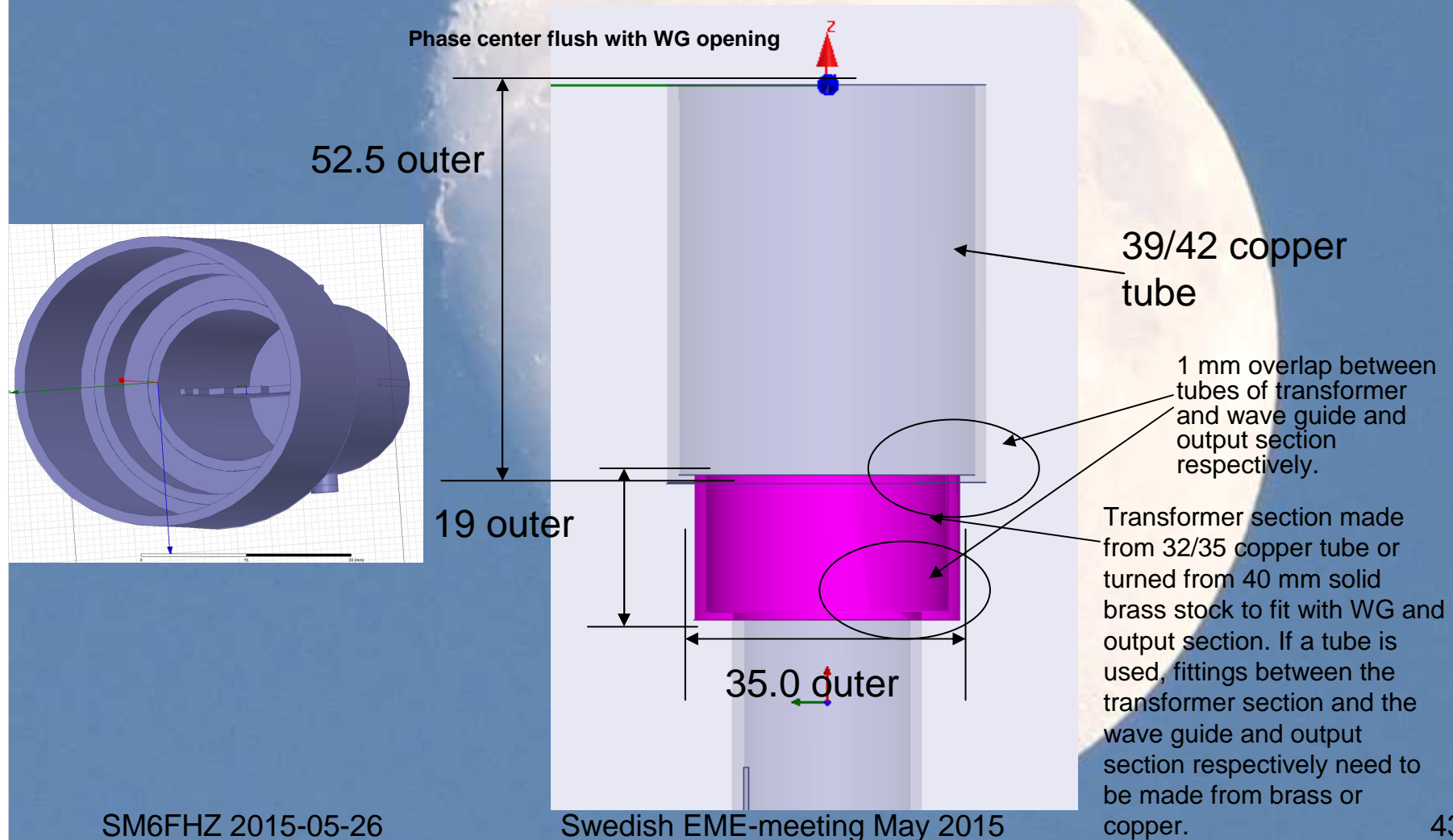

Septum dimensions

(3 cm 0.760 wl WG Dual Mode 39mm)

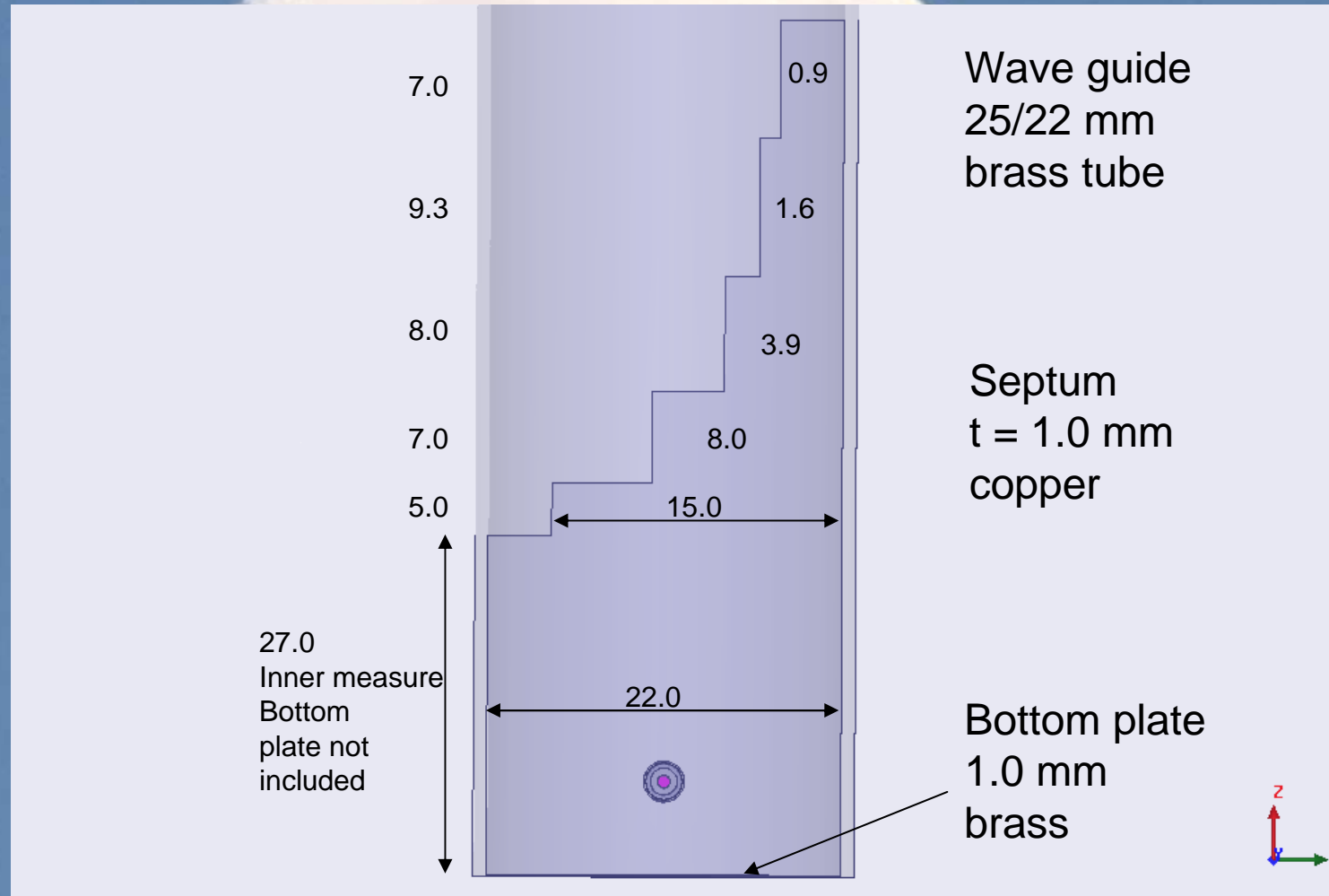

A large, bright, cratered moon is shown in a clear blue sky. The moon is the central focus, with its surface covered in numerous craters of various sizes. The text is overlaid on the moon's surface.

InDish Performance

A quick look at all 3 feed aperture variations

InDish Performance 3 cm (0.6 m dish)

SM6FHZ 3cm Kumar Septum Feed 0.692w1 WG

SM6FHZ 3cm Kumar Septum Feed 0.760w1 WG

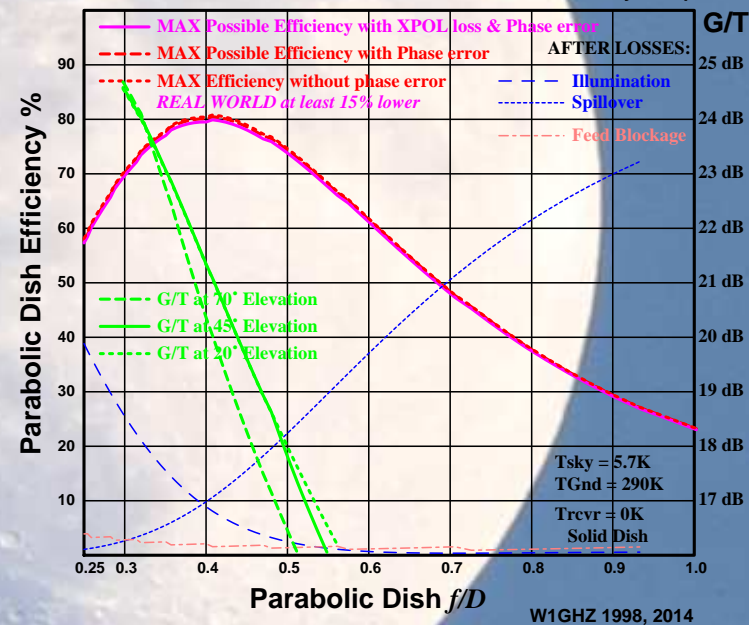
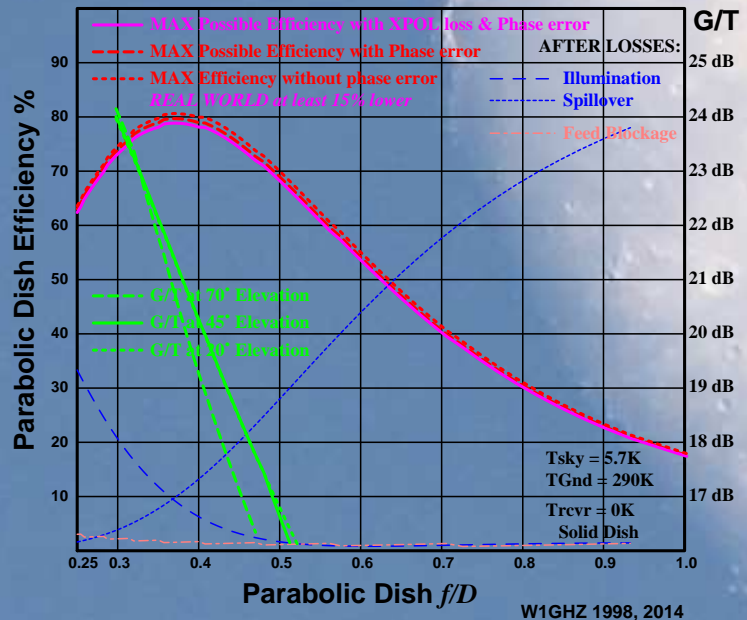
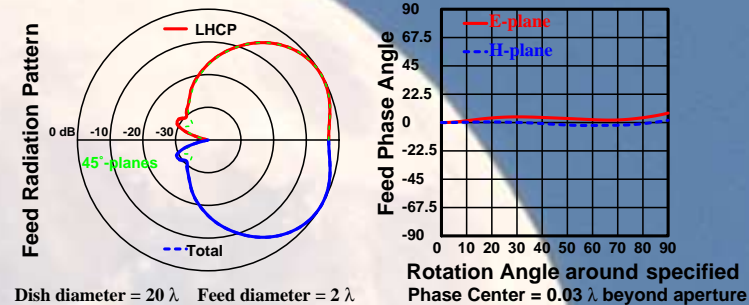
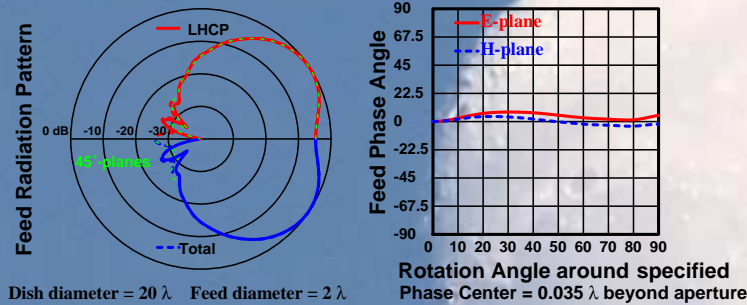

3 cm 0.692 L W/G feed performance

3 cm 0.760 L W/G feed performance

InDish Performance 3 cm (0.6 m dish)

SM6FHZ 3cm DualMode Septum Feed

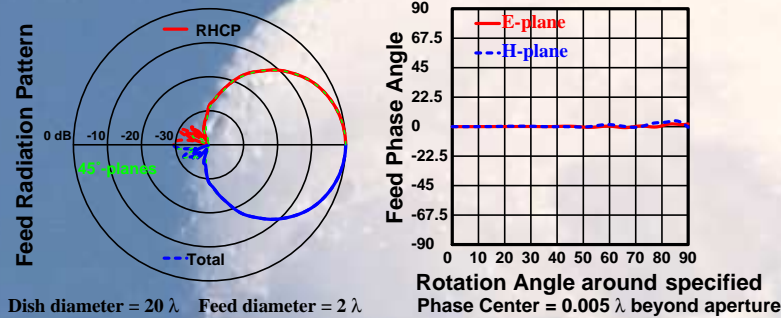

Dish diameter = 20λ Feed diameter = 2λ

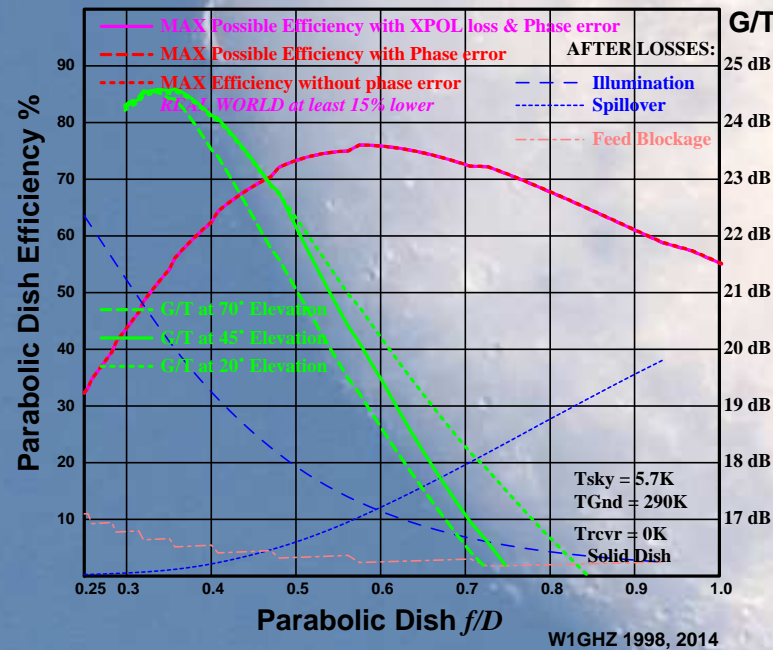

3 cm 0.760 L W/G Dual Mode feed performance

Realization

9, 6 and 3 cm feeds comparison

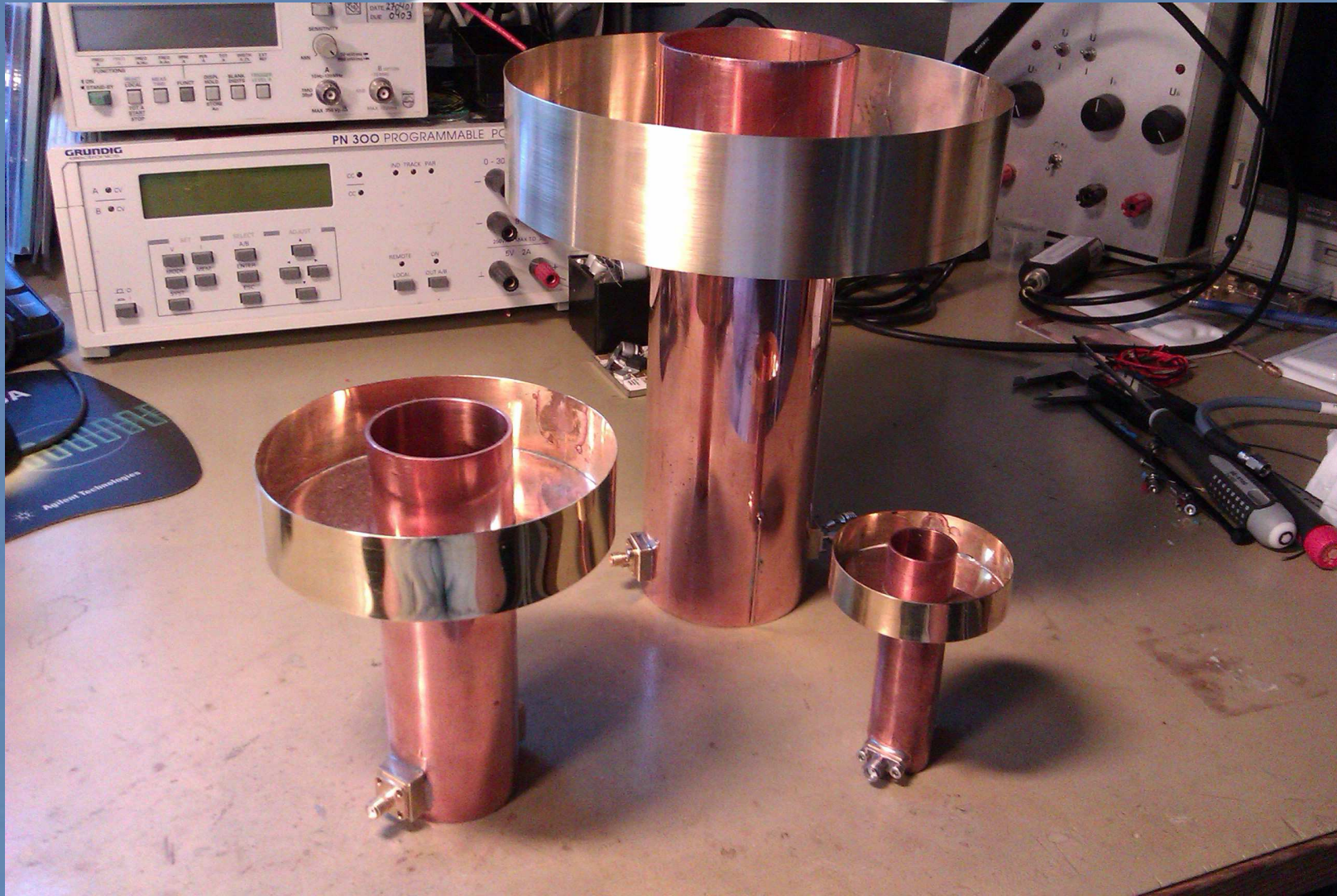

Lessons Learned

- Scaling feed dimensions from a one band design to another band is at your own risk
 - The material used (thickness etc) plays a important role. It is not obvious how to scale material thickness. **I argue that you will not know what radiation pattern you will get if scaled.**
- Soldering of the septum to 100% is crucial
 - This is true for all soldering joints in the feed
- The inner WG diameter is sensitive to tolerances
 - 0.2 mm larger diameter on 10 GHz moved the optimum isolation >100 MHz down

Acknowledgements



- Thanks to all who inspired me to do this work and that gave me so many good ideas:
 - W1GHZ, Paul
 - VE4MA, Barry
 - W2IMU, Dick
 - SM6PGP, Hannes
 - WD5AGO, Tommy
 - N2UO, Marc
 - RA3AQ, Dmitry
 - OK1DFC, Zdenek
 - OM6AA, Rasto
 - Plus many others

References

- Copper tubes (9 cm, 6 cm and 3 cm feeds) can be found here:
 - <http://www.rinkabyror.se/artiklar/ror-och-rordelar/harda-kopparror-prisol/>
 - http://www.engineeringtoolbox.com/copper-tube-working-pressure-d_20.html
 - http://www.onlinemetals.com/merchant.cfm?id=84&step=2&top_cat=79
 - <http://www.hpb.se/vvs/156-koppar>

Conclusion

- 6 new septum feeds on 3 cm have been presented, all of them show very good performance
- The feeds are based on standard metric and inch Cu or brass tubes for easy manufacturing
- The rationale behind the designs and solutions has been discussed
- An alternative polarizer solution has been assessed
- Validity of EM-simulations has been assessed and discussed

Thank you for your attention

See you all via the moon on the higher bands



A large, bright, cratered moon is shown against a clear blue sky. The moon is the central focus, with its surface covered in numerous craters of various sizes. The text is overlaid on the moon's surface.

Details of all the feeds

**Dimensions and performance for
all variations**

A large, bright, cratered moon is shown against a clear blue sky. The moon is the central focus, with its surface covered in numerous craters of various sizes. The text is overlaid on the moon's surface.

SM6FHZ 3 cm 5 step septum
feed

0.692 lambda W/G

Solid and transparent models from the simulation (3 cm 0.692 wl WG)

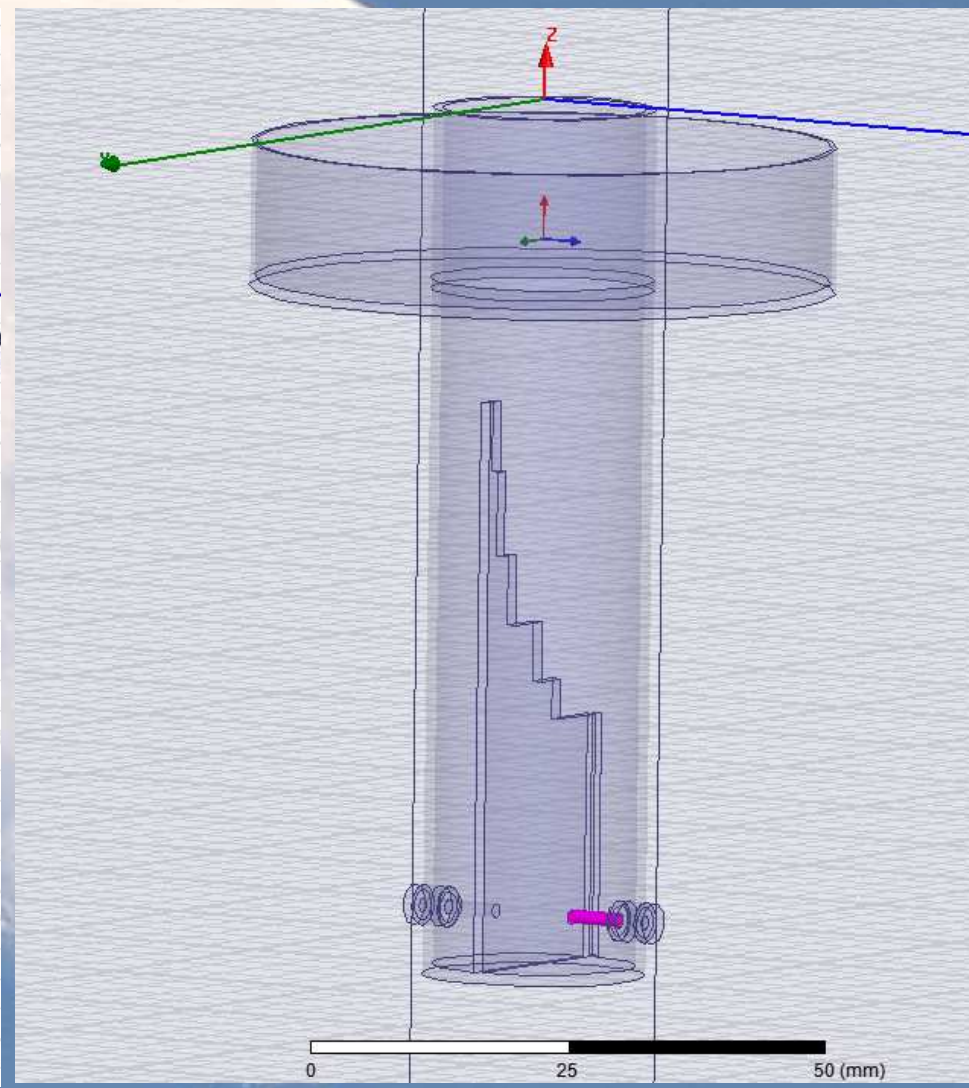
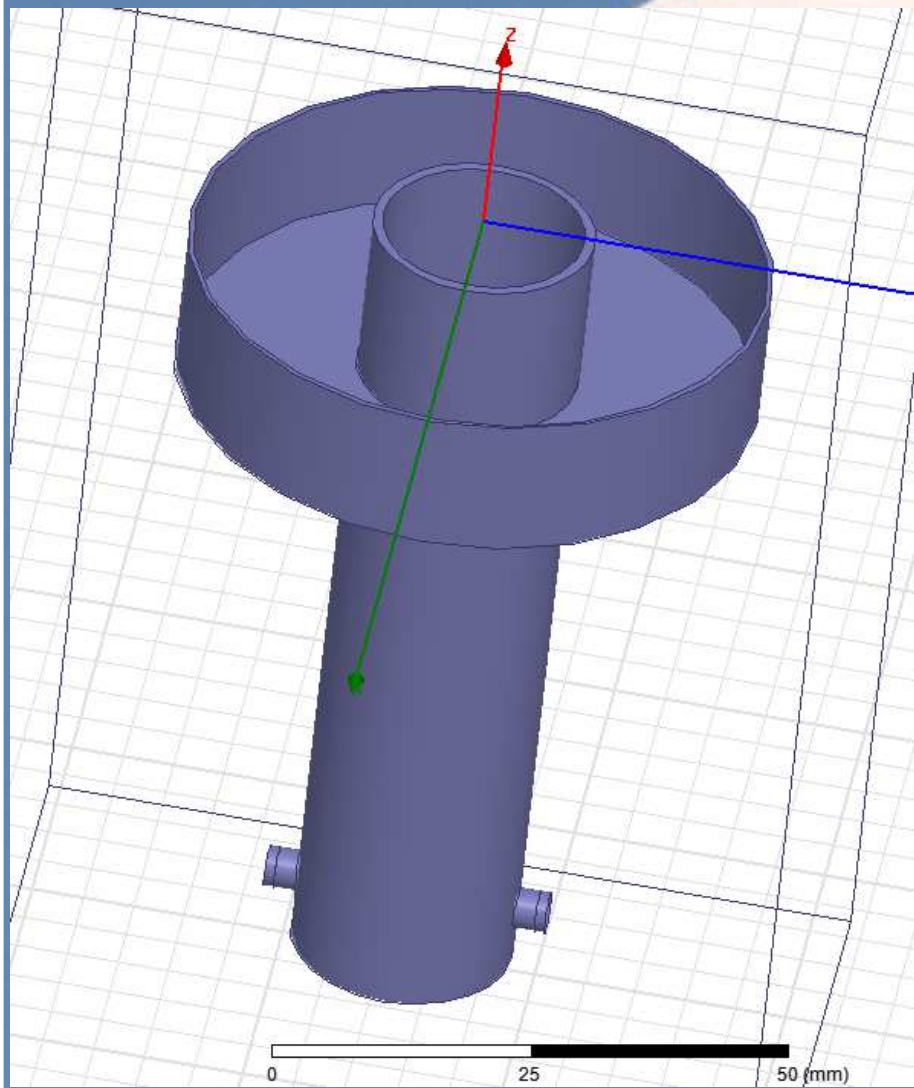

WG and choke dimensions (3 cm 0.692 wl WG)

Circular polarization convention for EME according to Crawford Hill Bulletin No 1:

Tx RHCP in space
Rx LHCP in space

Take polarization reversal into account when using reflector antennas.

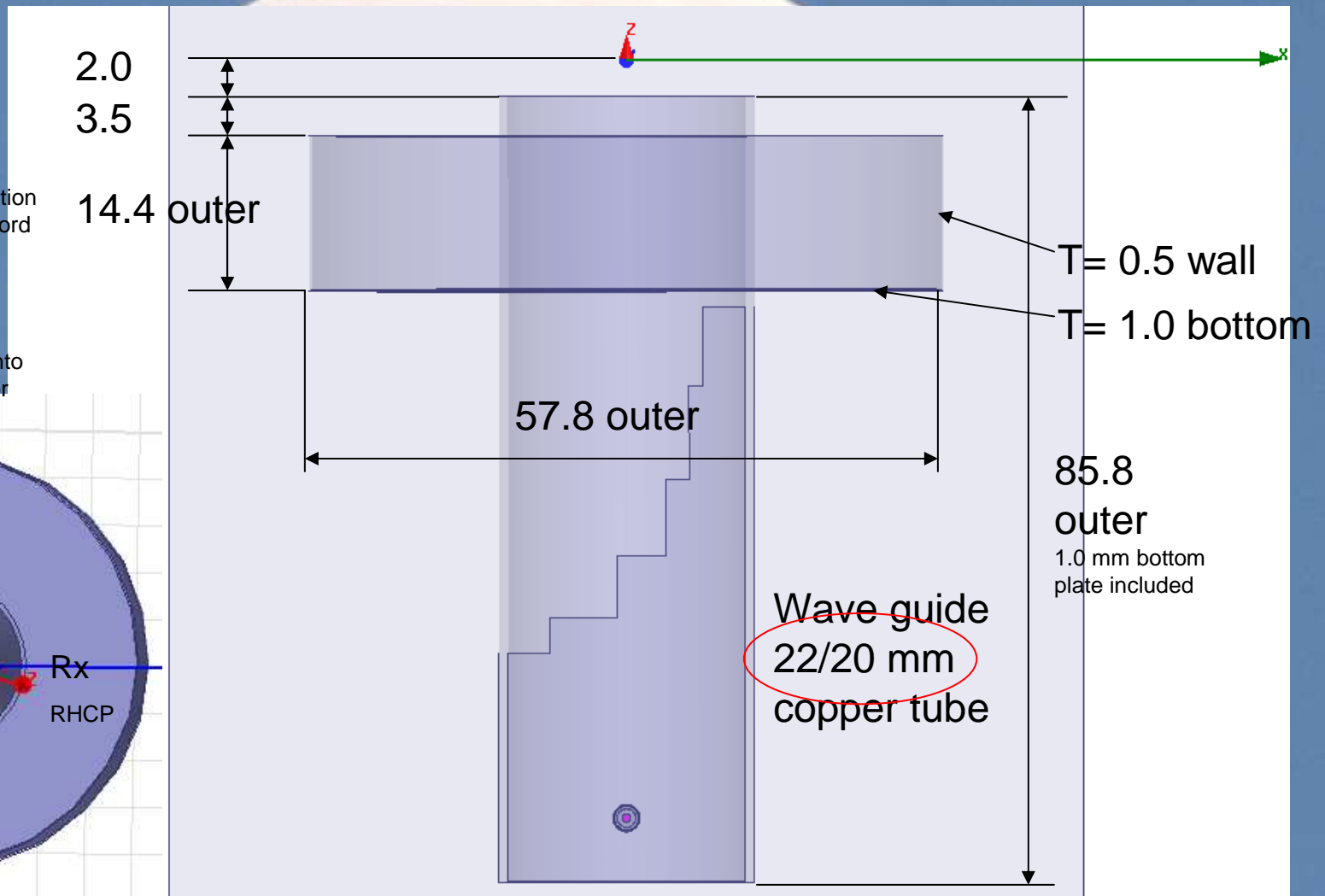
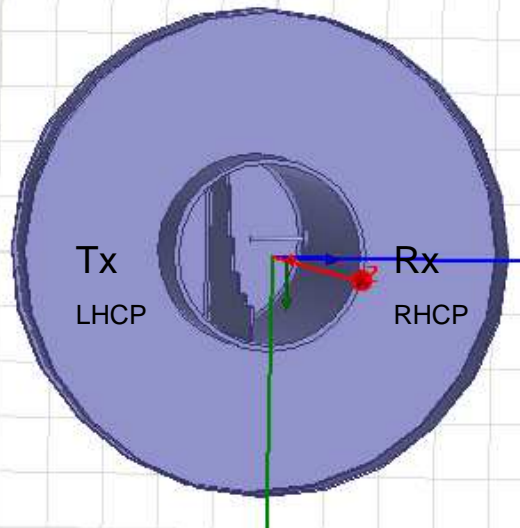

Septum dimensions (3 cm 0.692 wl WG)

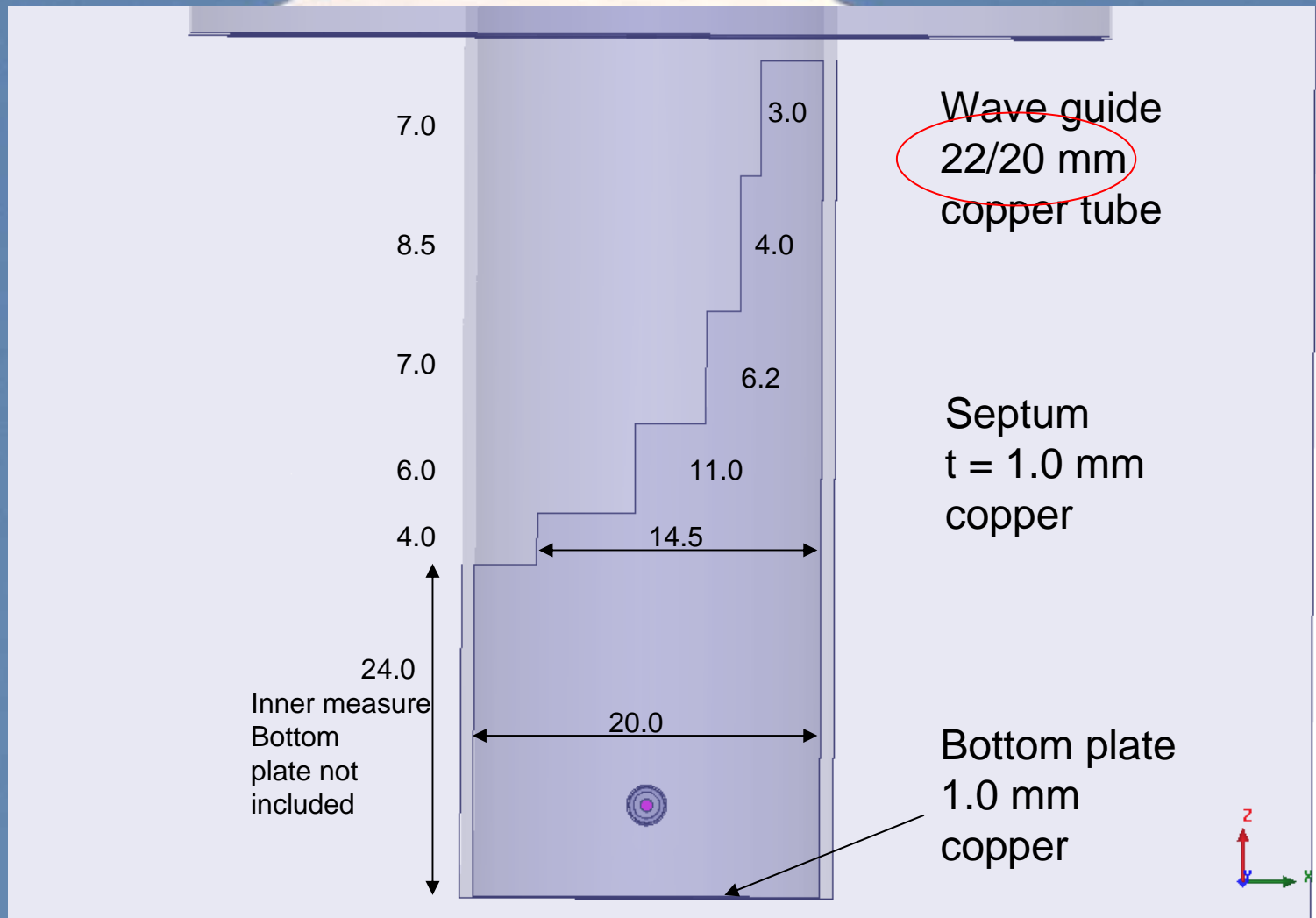

Probe dimensions (3 cm 0.692 wl WG)

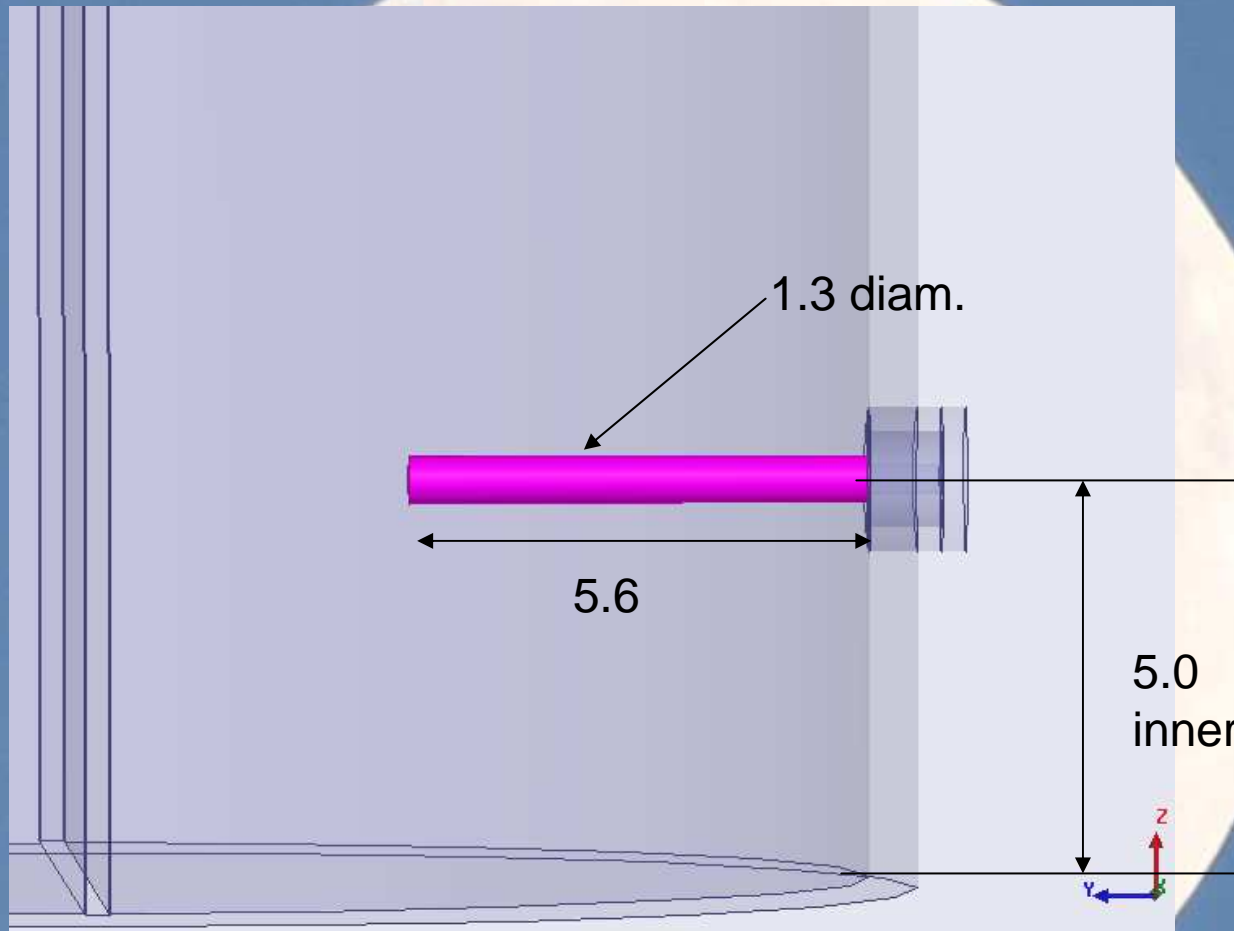

S11, S22, S21 combined

(3 cm 0.692 wl WG)

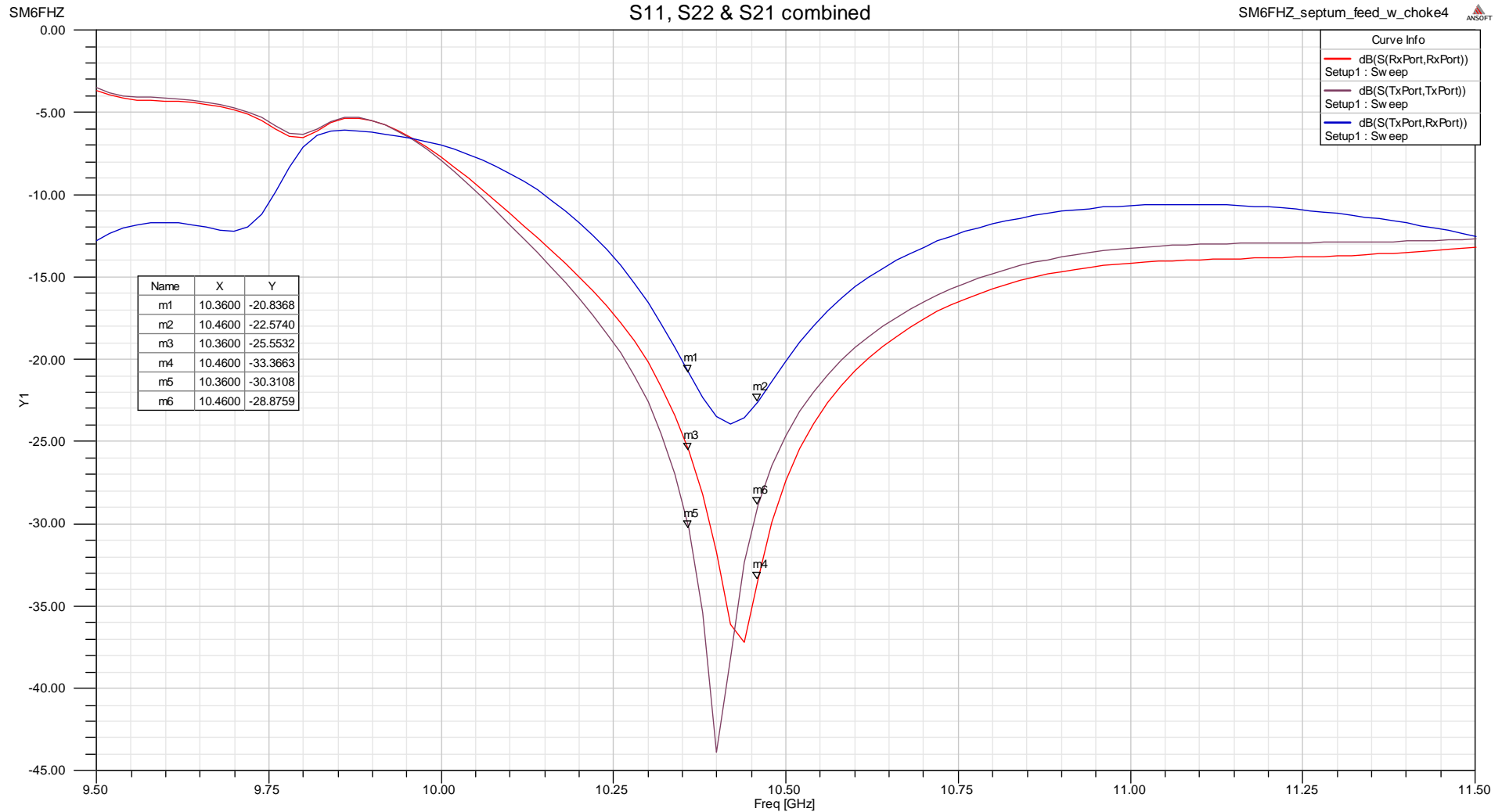

3D Total Power Far Field pattern

(3 cm 0.692 wl WG)

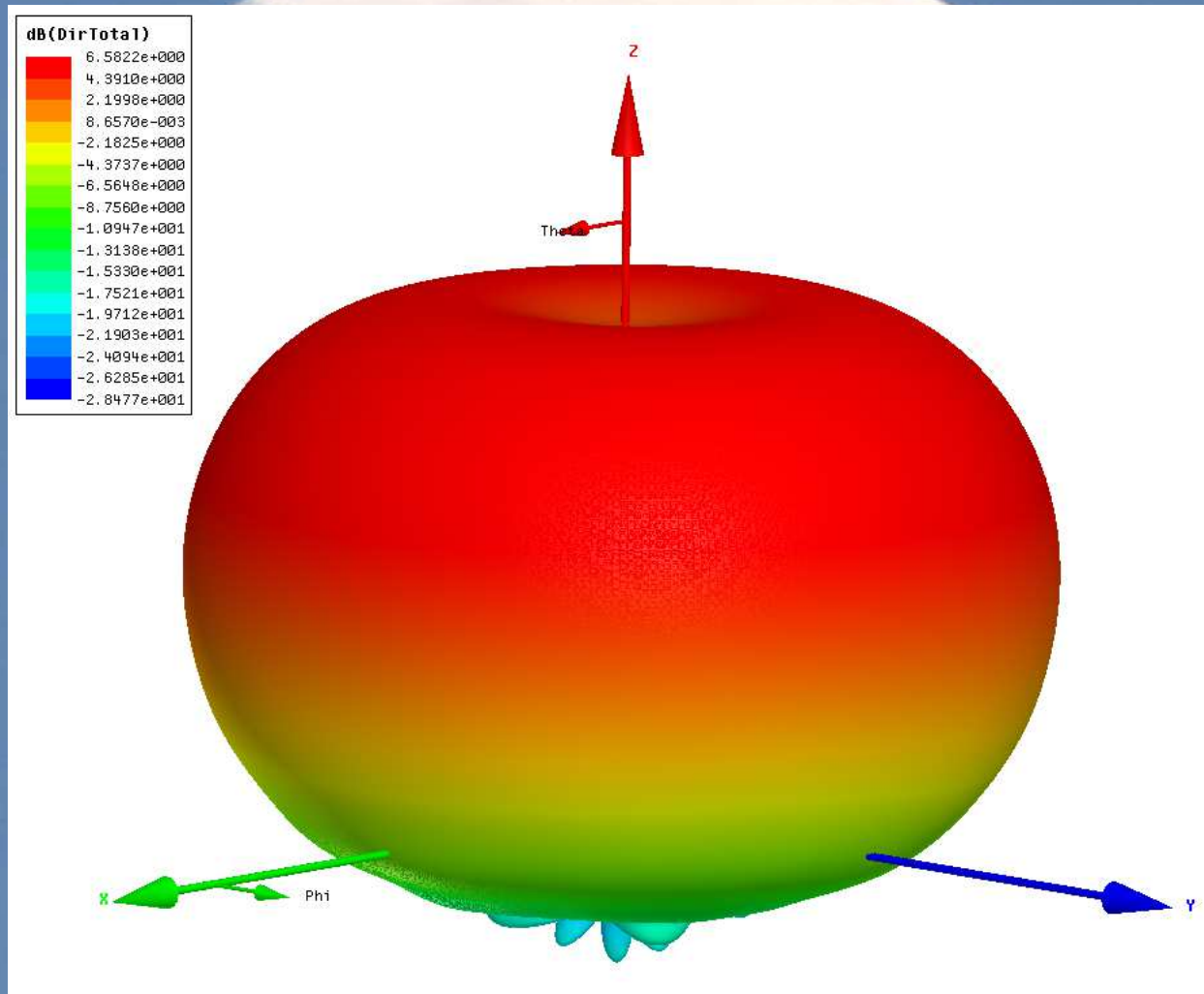

Far Field Pattern 0 deg (3 cm 0.692 wl WG)

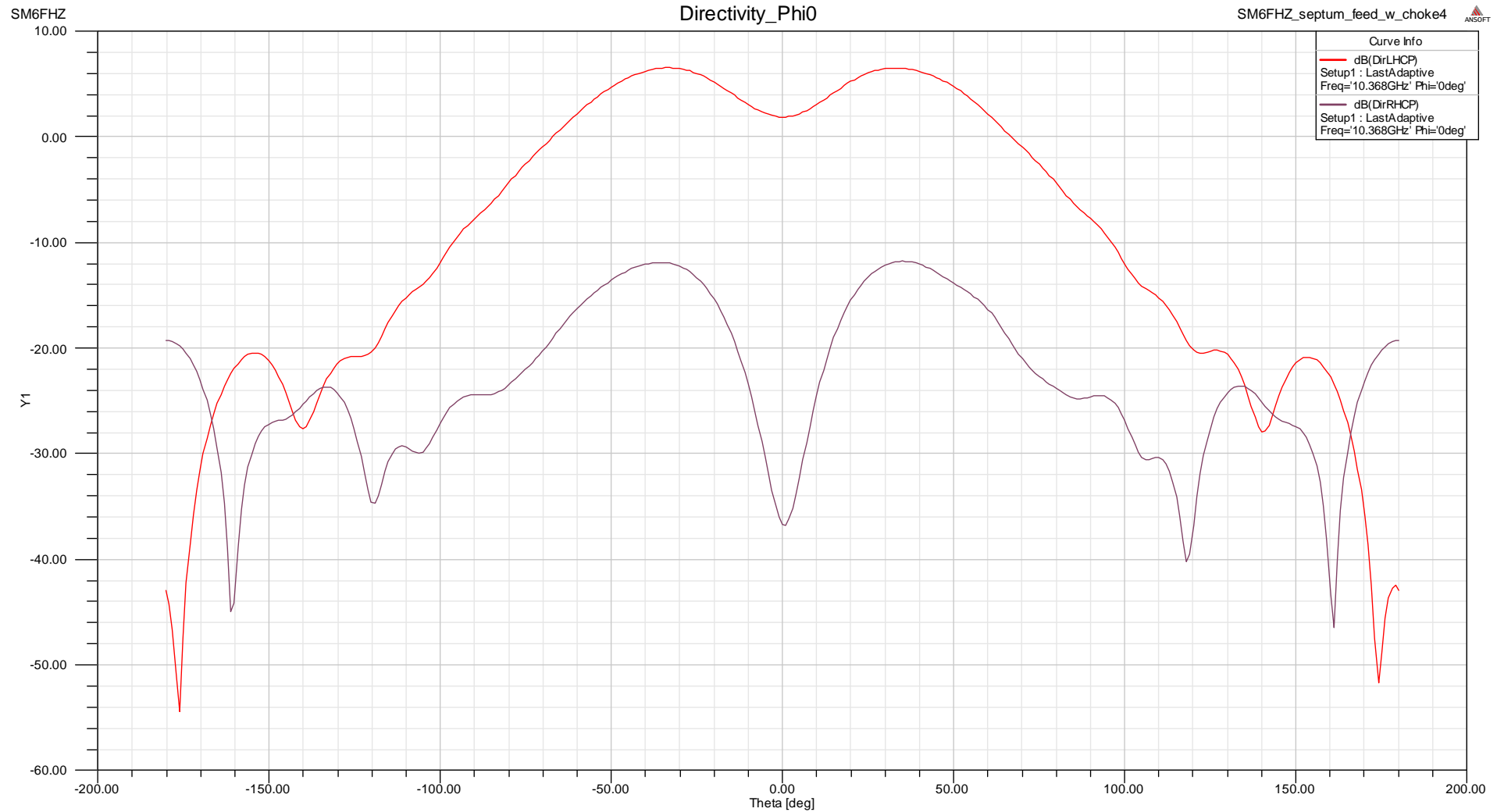

Far Field Phase (3 cm 0.692 wl WG)

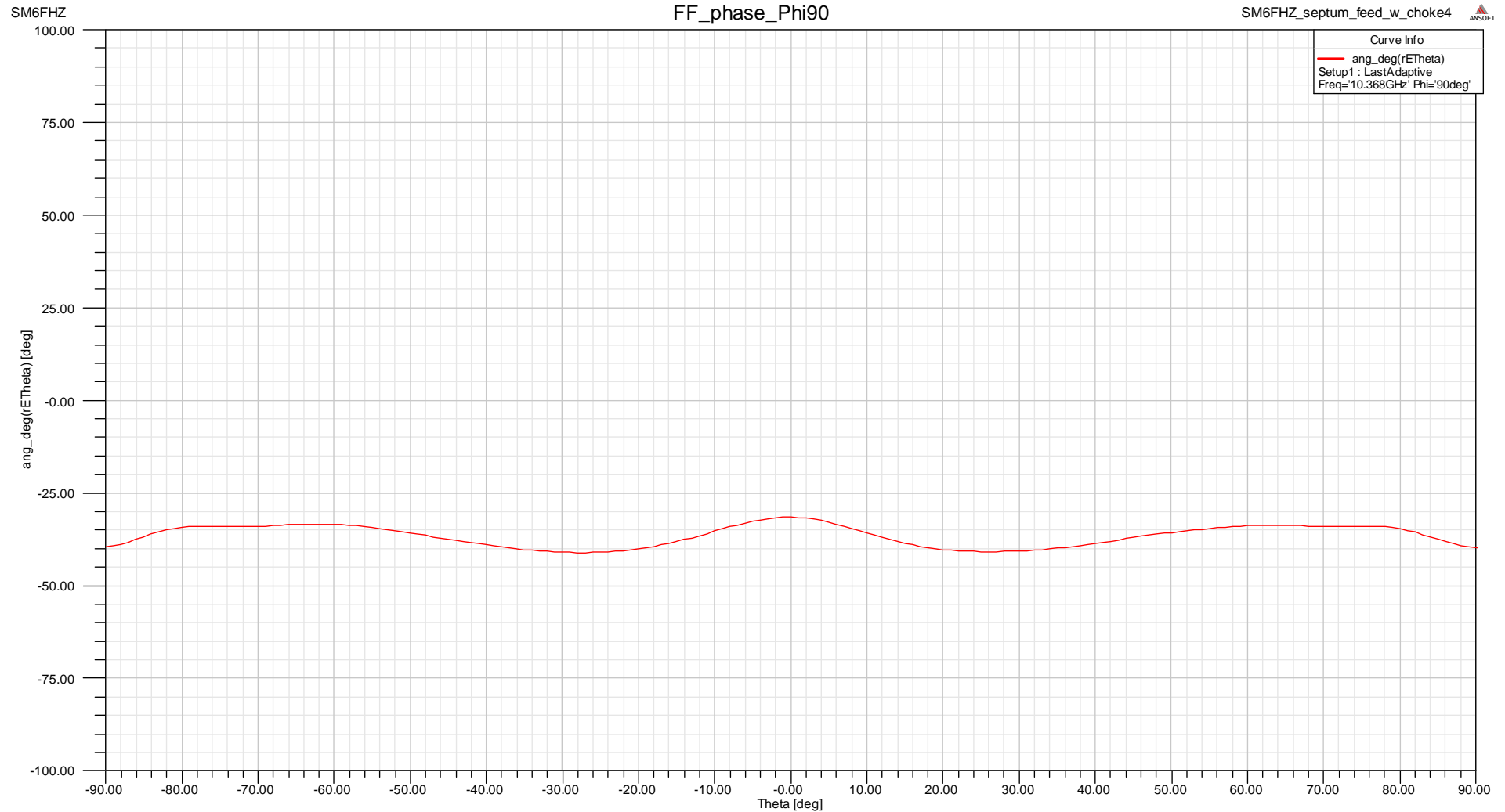

Cross Polar Ratio (3 cm 0.692 wl WG)

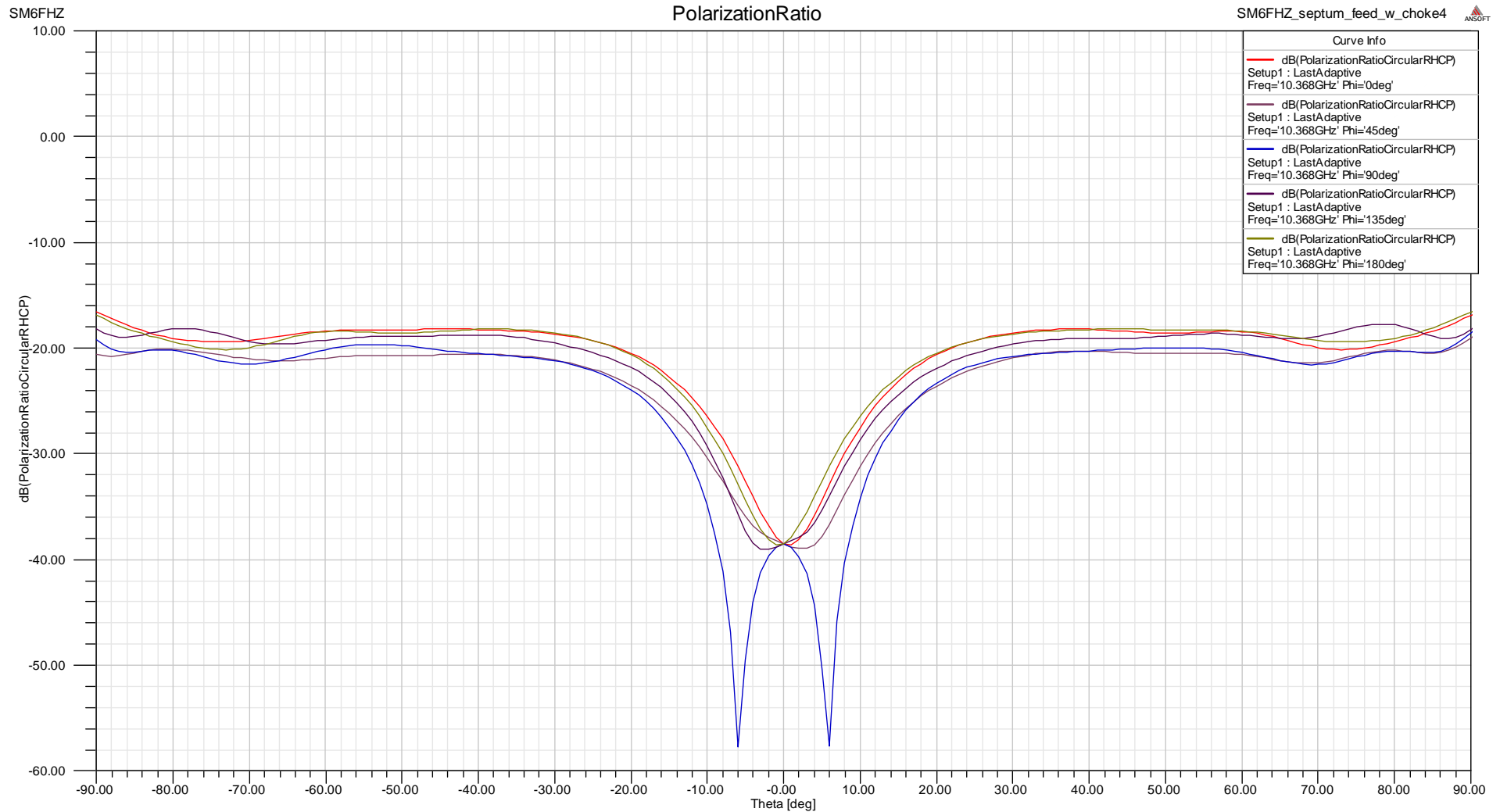

Axial Ratio (3 cm 0.692 wl WG)

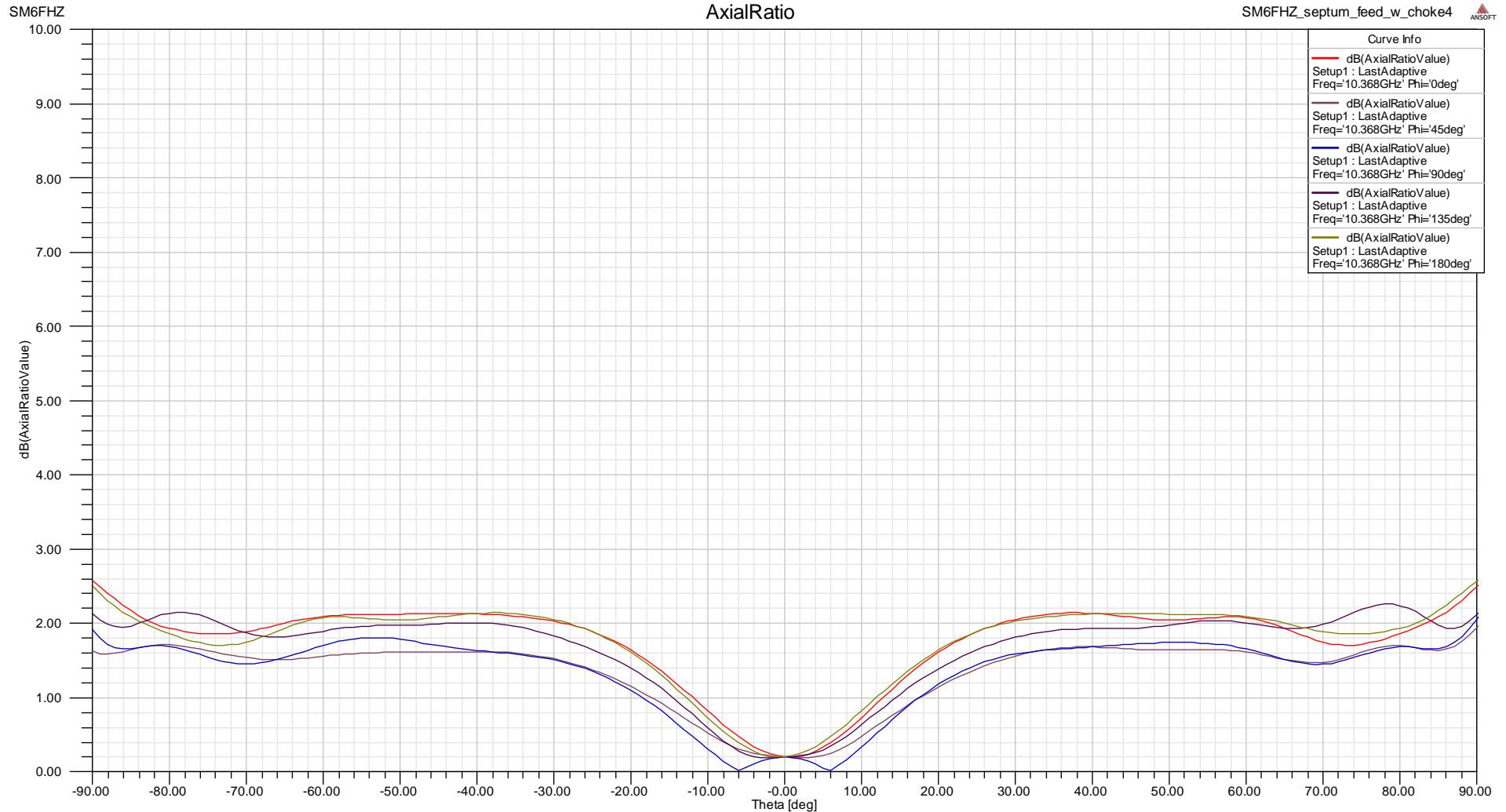

Realization (3 cm 0.692 wl WG)

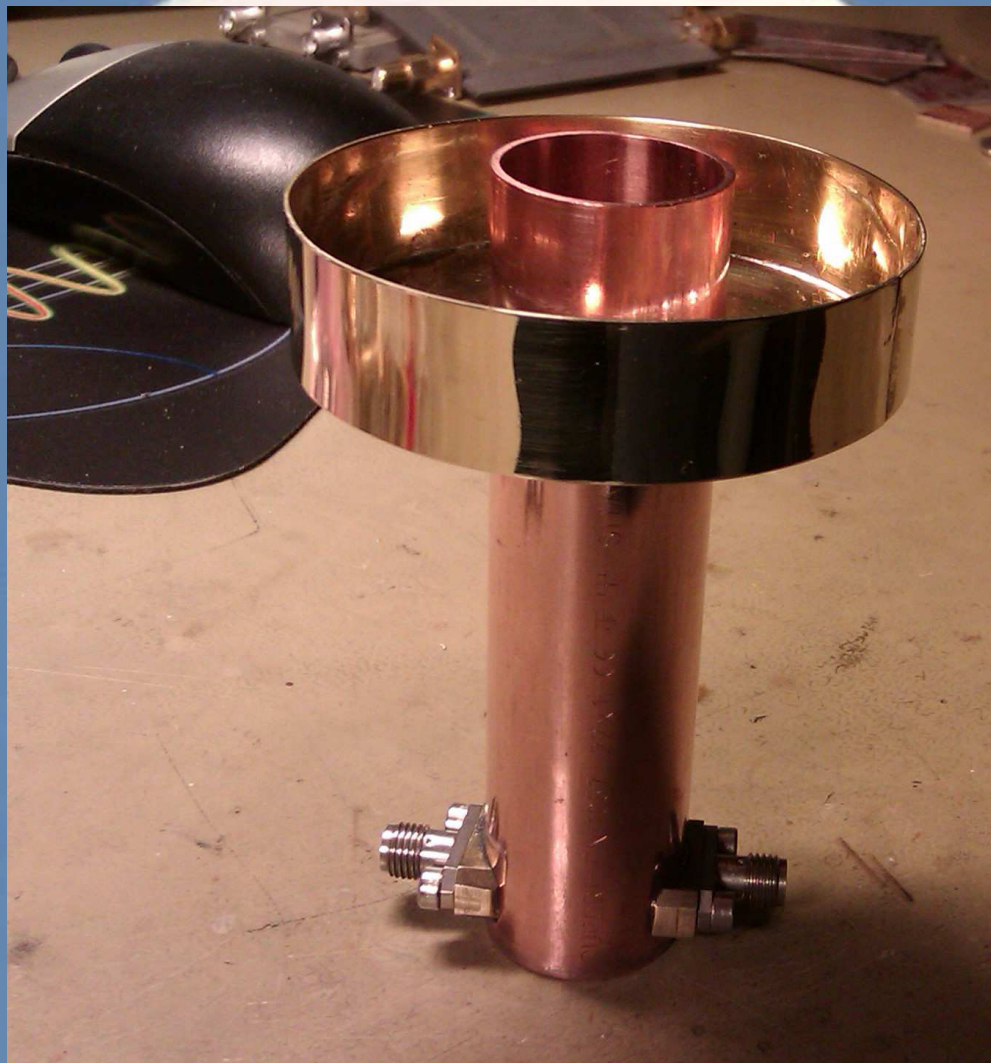

+0.2 mm WG-diam, +1 mm septum, +1 mm WG-length (3 cm 0.692 wl WG)

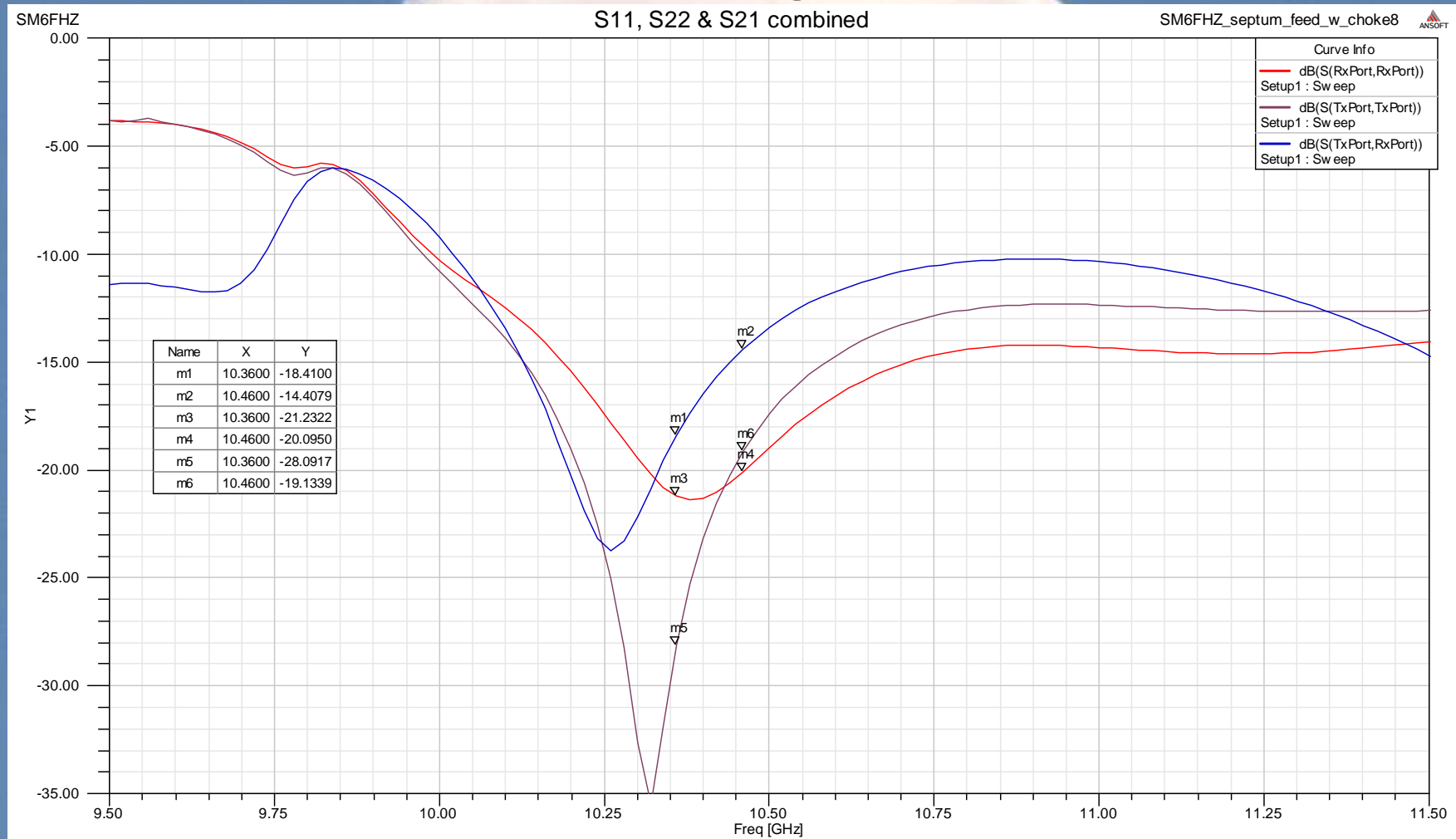

WG and choke dimensions (3 cm 0.692 wl WG)

Circular polarization convention for EME according to Crawford Hill Bulletin No 1:

Tx RHCP in space
Rx LHCP in space

Take polarization reversal into account when using reflector antennas.

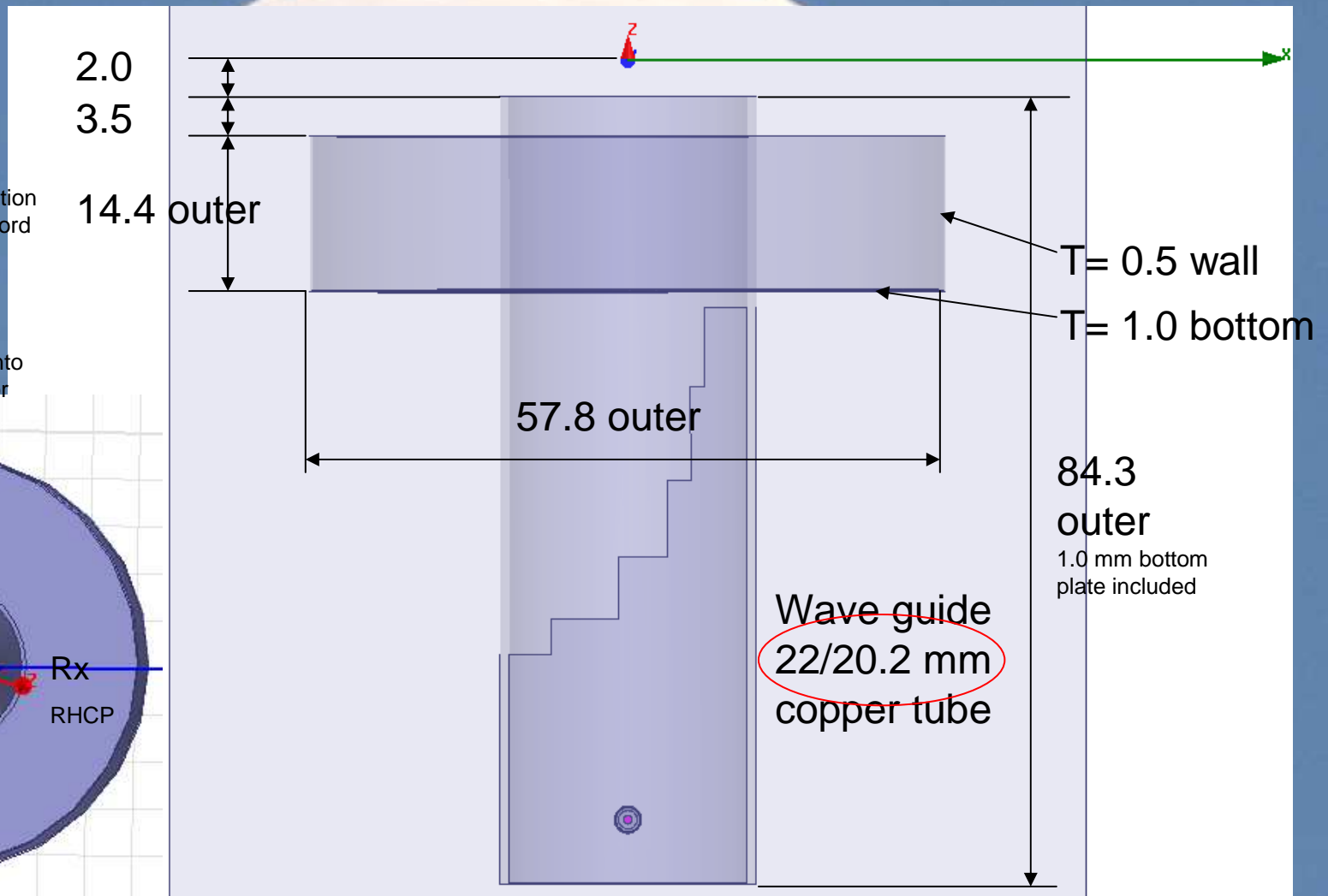
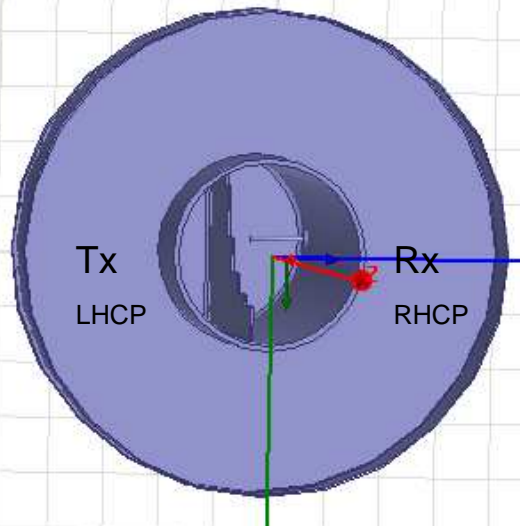

Septum dimensions (3 cm 0.692 wl WG)

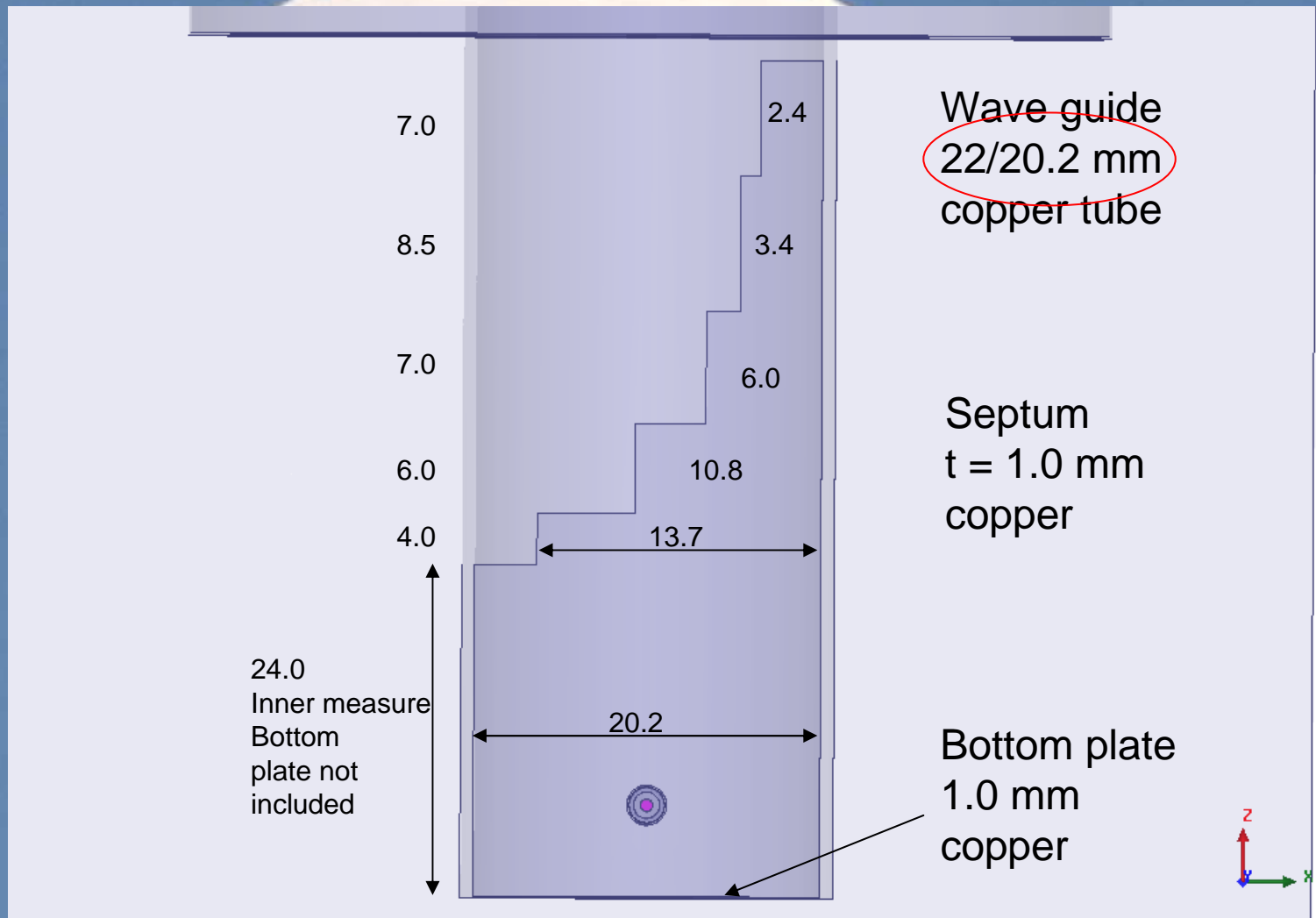

Probe dimensions (3 cm 0.692 wl WG)

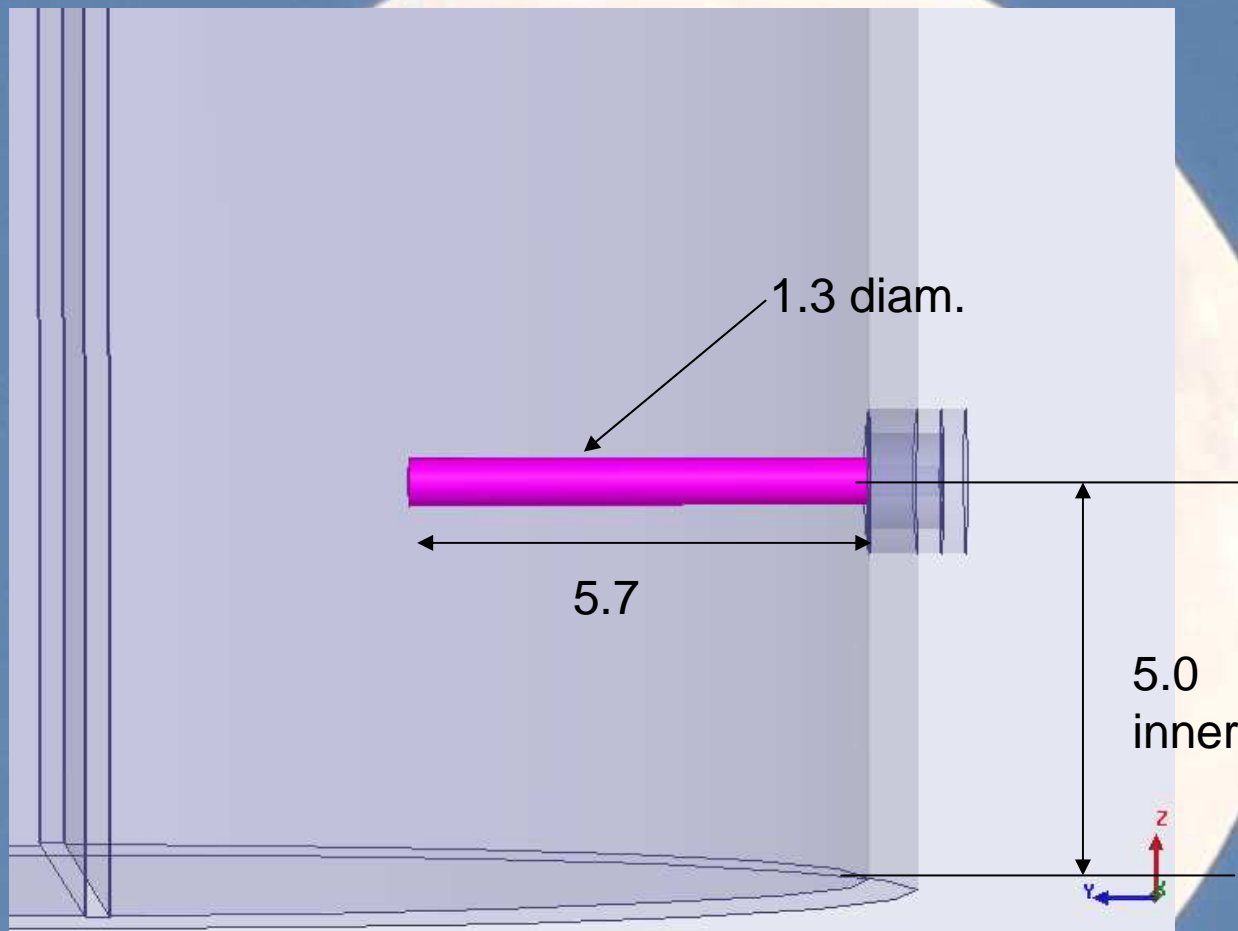

Short-cut for tuning Return Loss

- SM6PGP, Hannes, found that a small slug on the probe eased the tuning for optimum Return Loss
- Dimensions used;
Length: 2.3mm
Diameter: 2.5mm
Drill a 1.3mm hole for the connector pin.
Slide it along the probe for optimum performance

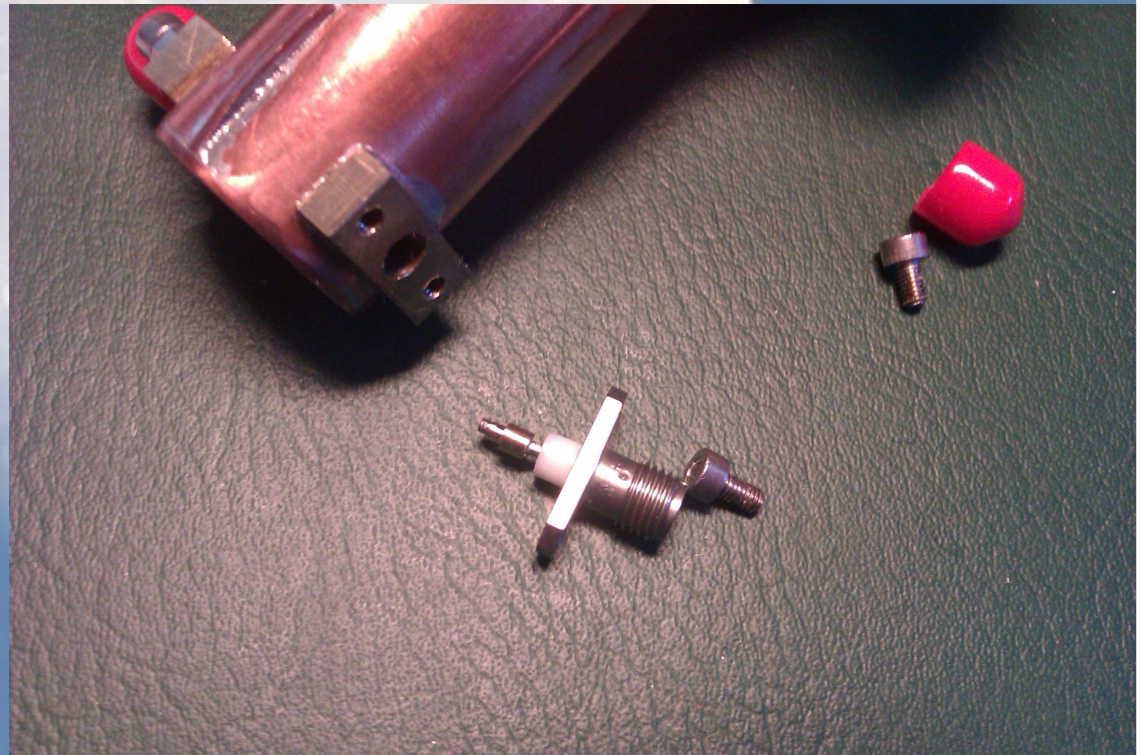

20,2 mm WG-inner diam optimized

(3 cm 0.692 wl WG)

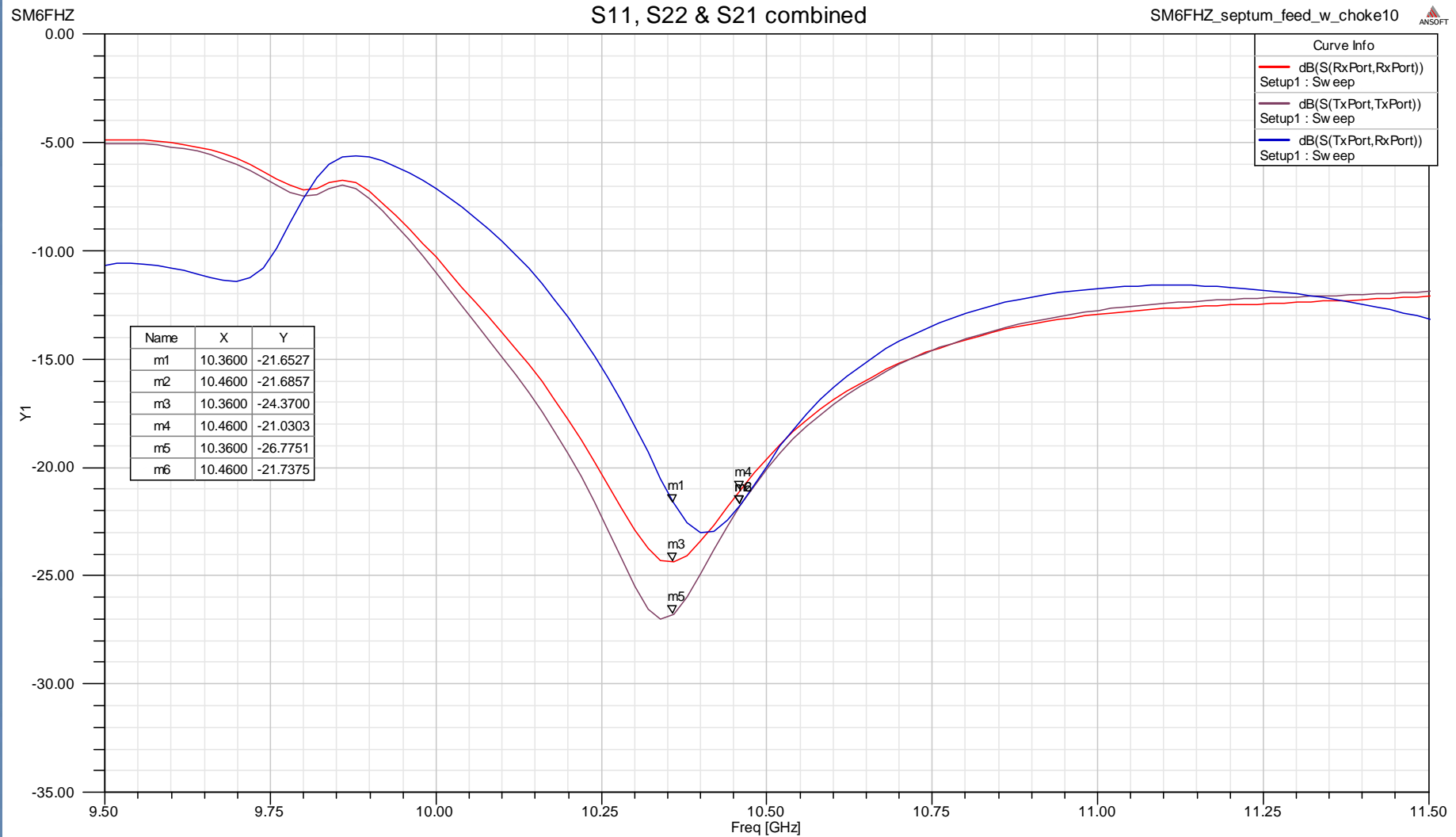

Measurements (3 cm 0.692 wl WG)

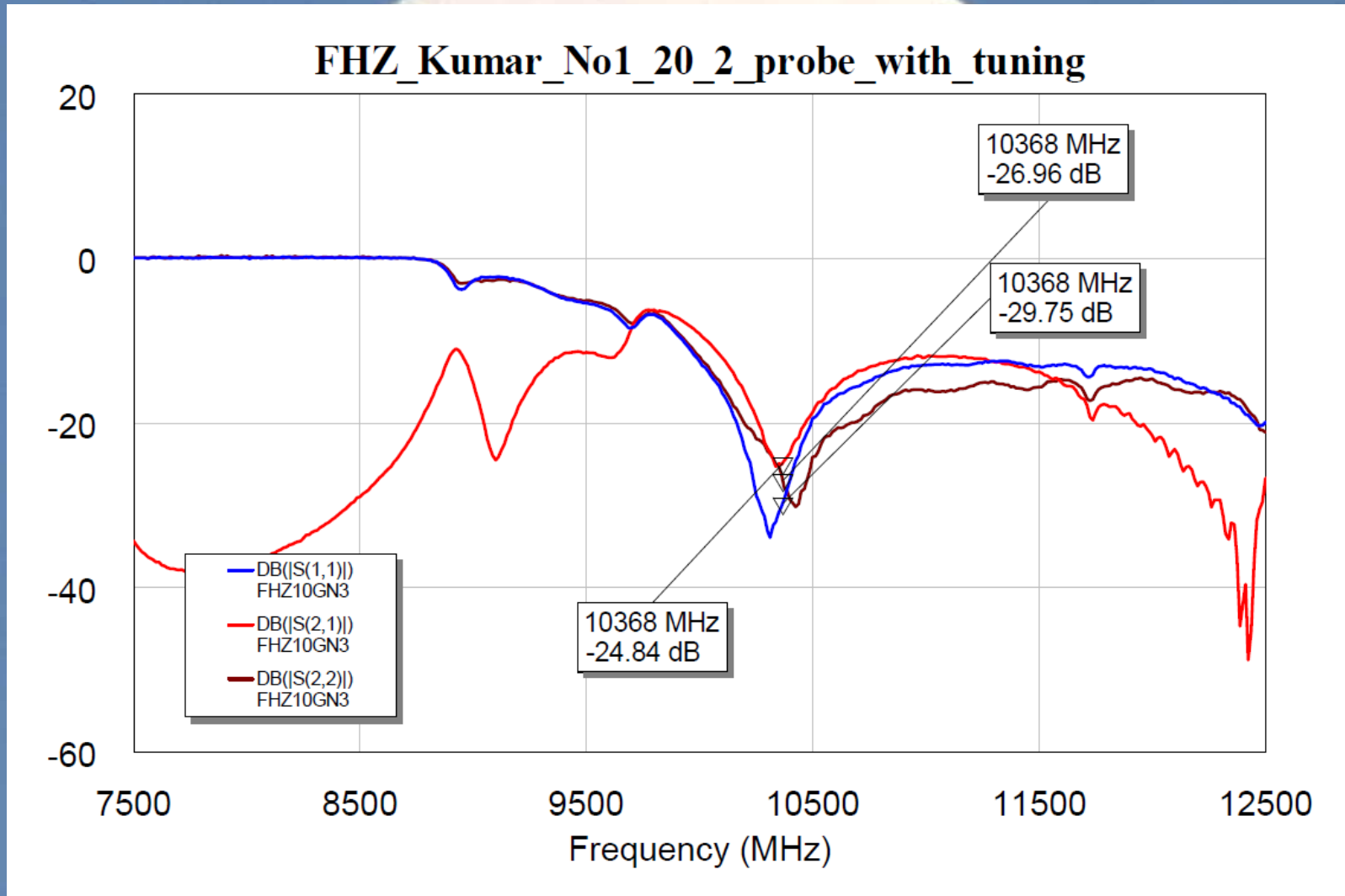

Far Field Pattern 0 deg (3 cm 0.692 wl WG)

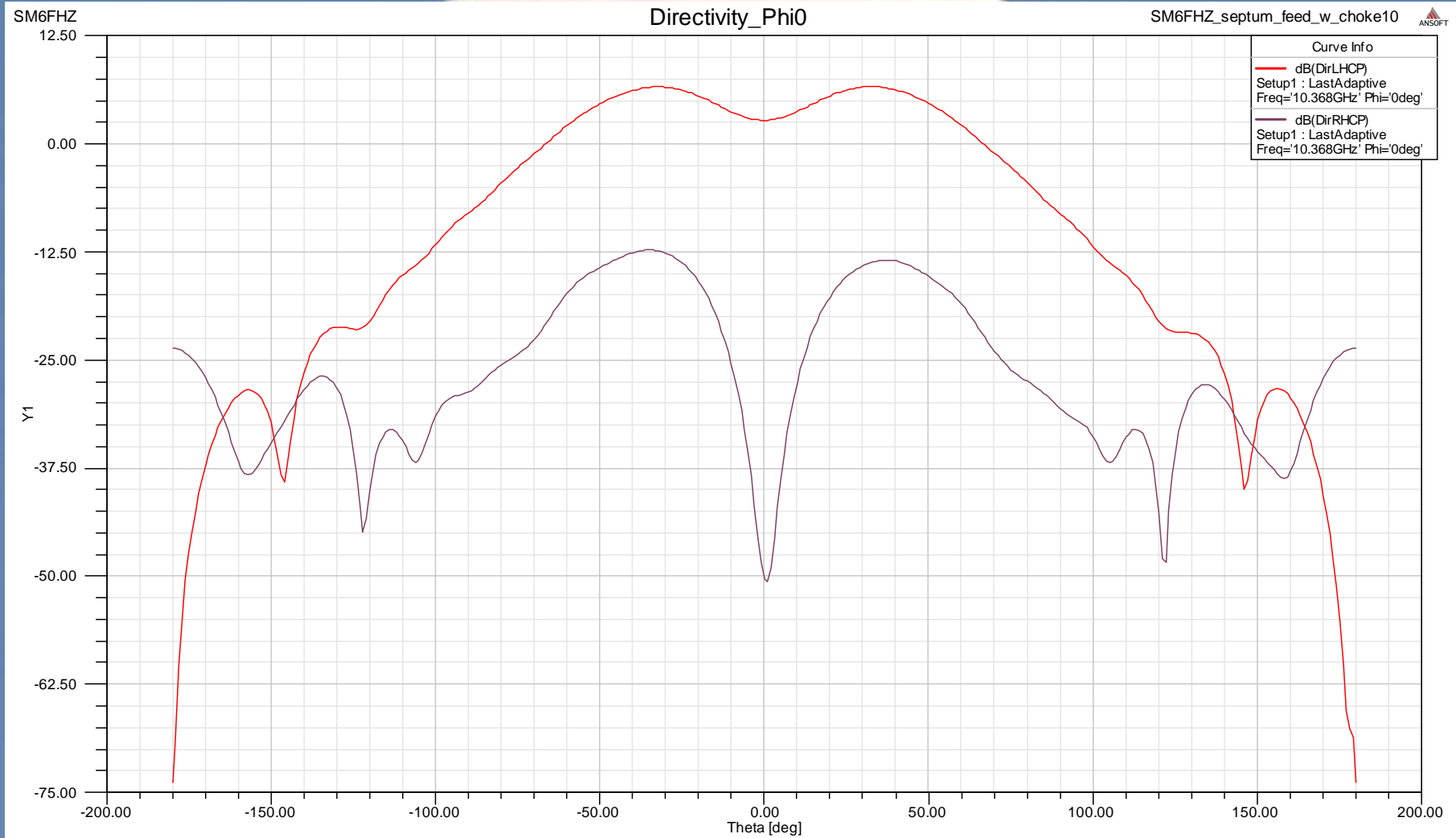

FF Phase error (3 cm 0.692 wl WG)

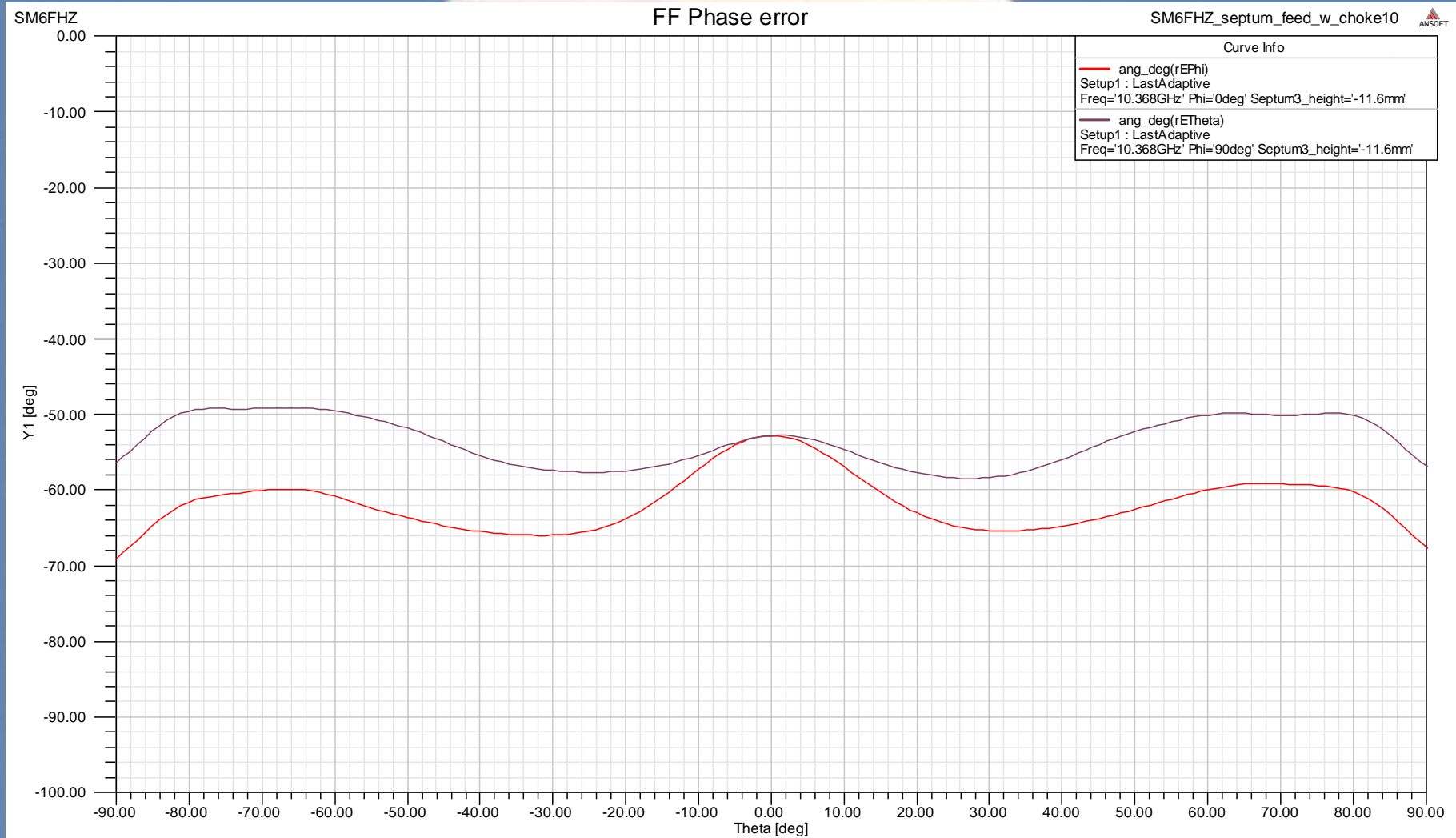

Axial Ratio (3 cm 0.692 wl WG)

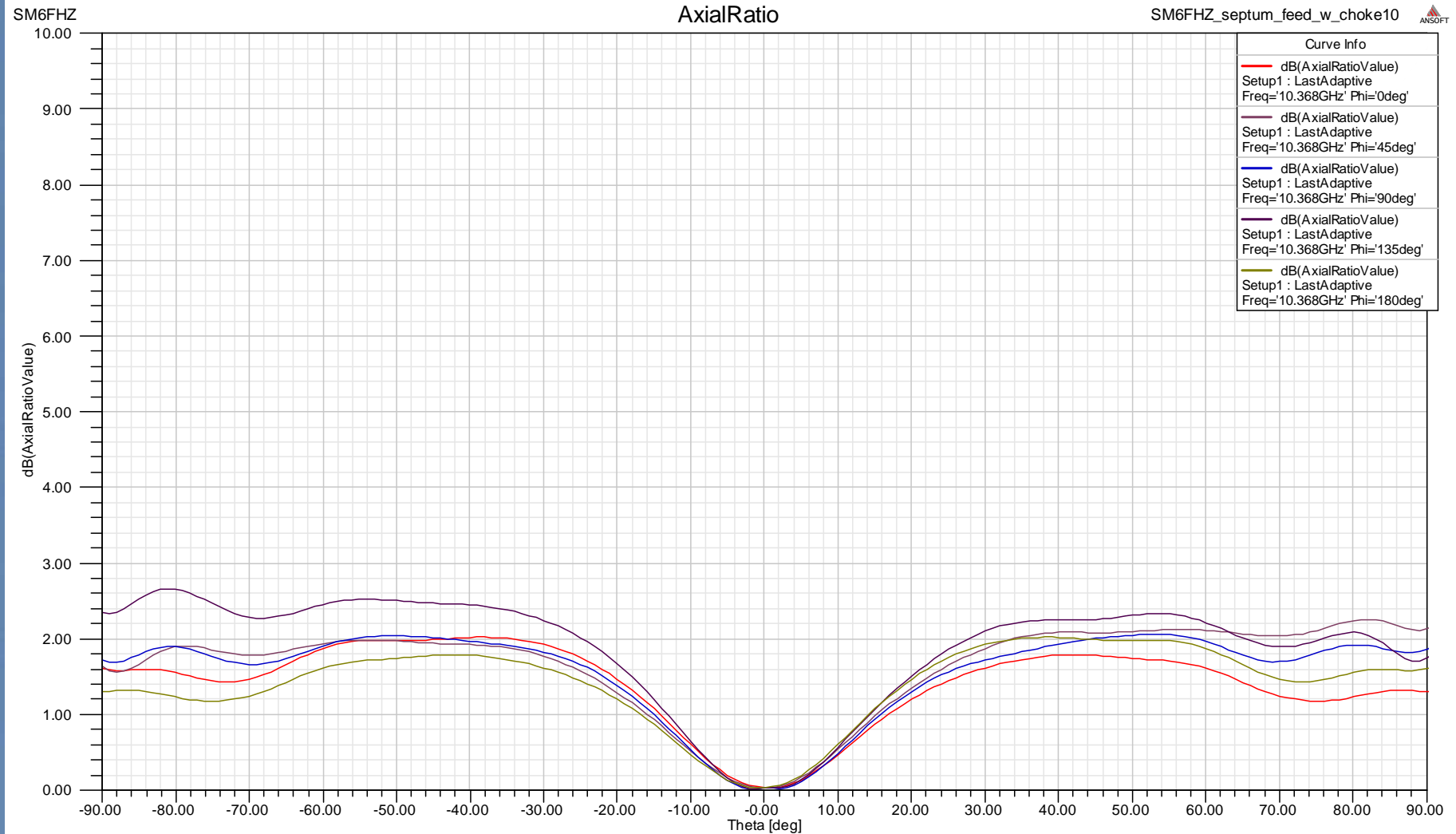



SM6FHZ 3 cm 5 step septum
feed

0.760 lambda W/G

Solid and transparent models from the simulation (3 cm 0.760 wl WG)

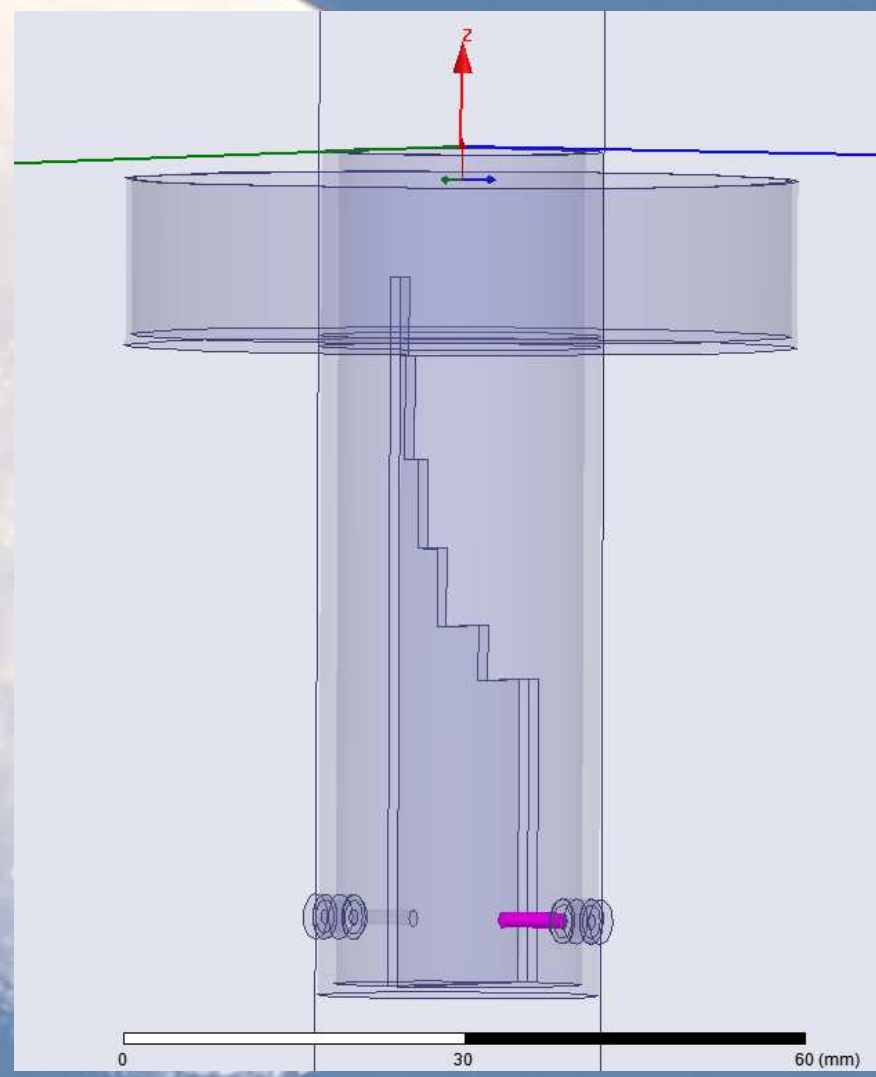
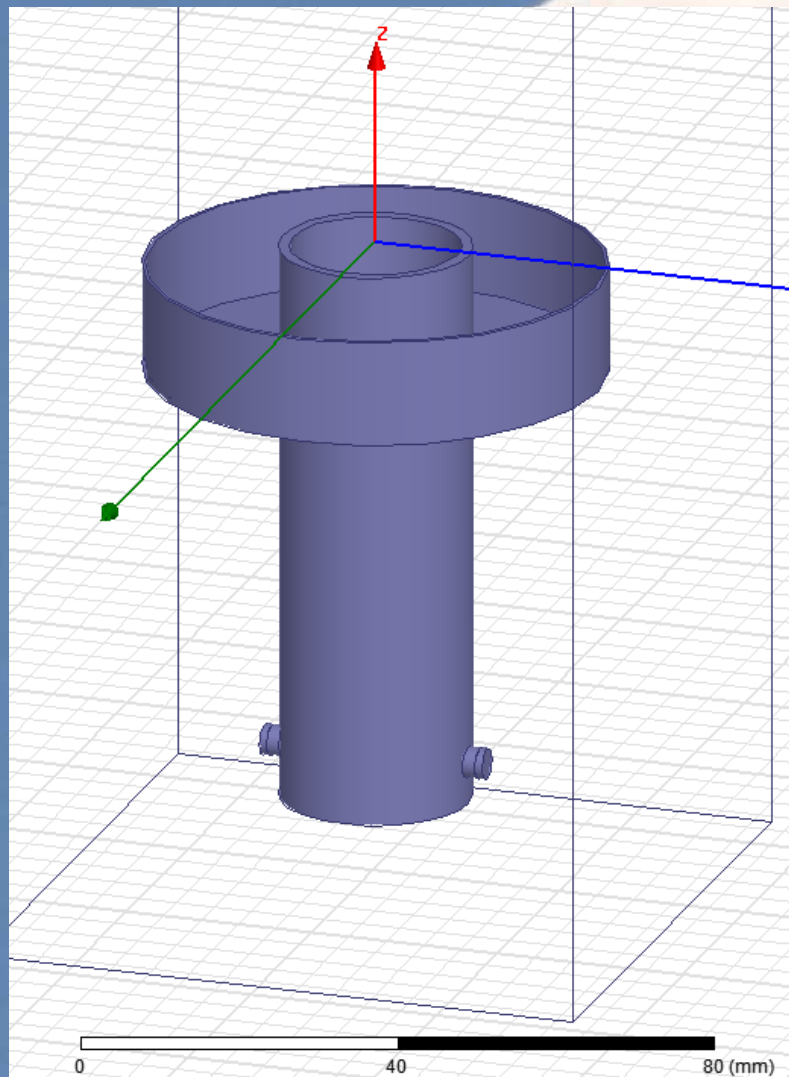

WG and choke dimensions (3 cm 0.760 wl WG)

Circular polarization convention for EME according to Crawford Hill Bulletin No 1:

Tx RHCP in space
Rx LHCP in space

Take polarization reversal into account when using reflector antennas.

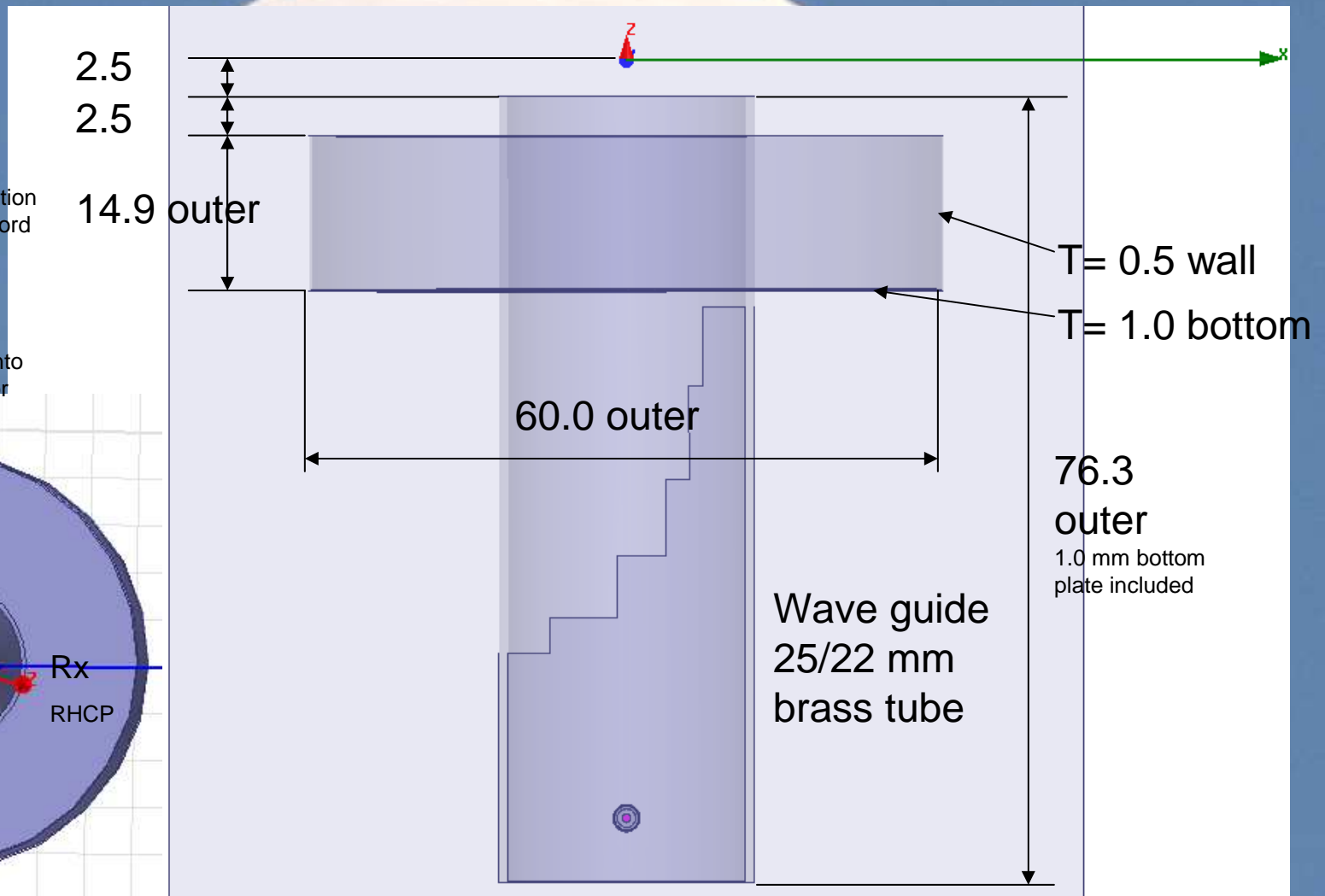
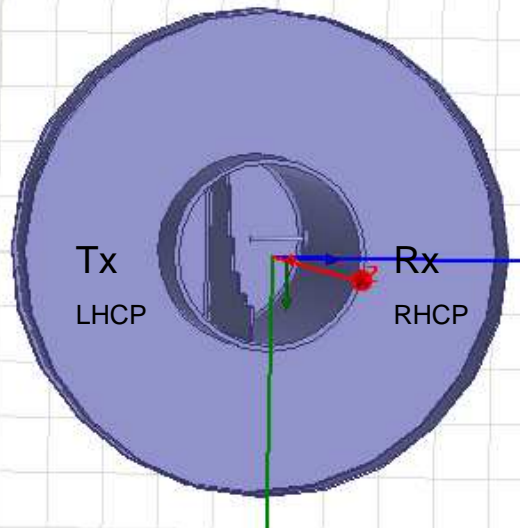

Septum dimensions (3 cm 0.760 wl WG)

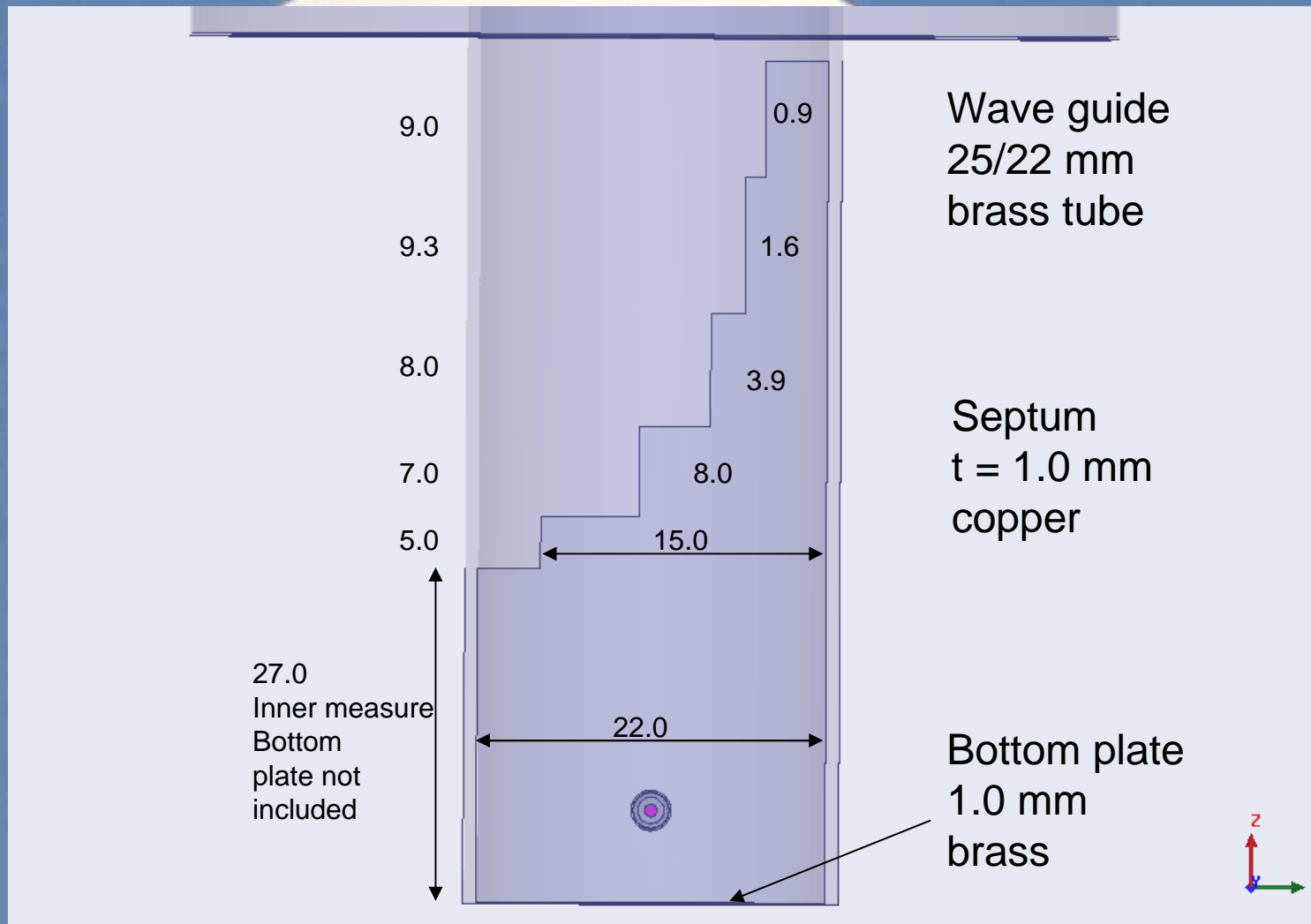

Probe dimensions (3 cm 0.760 wI WG)

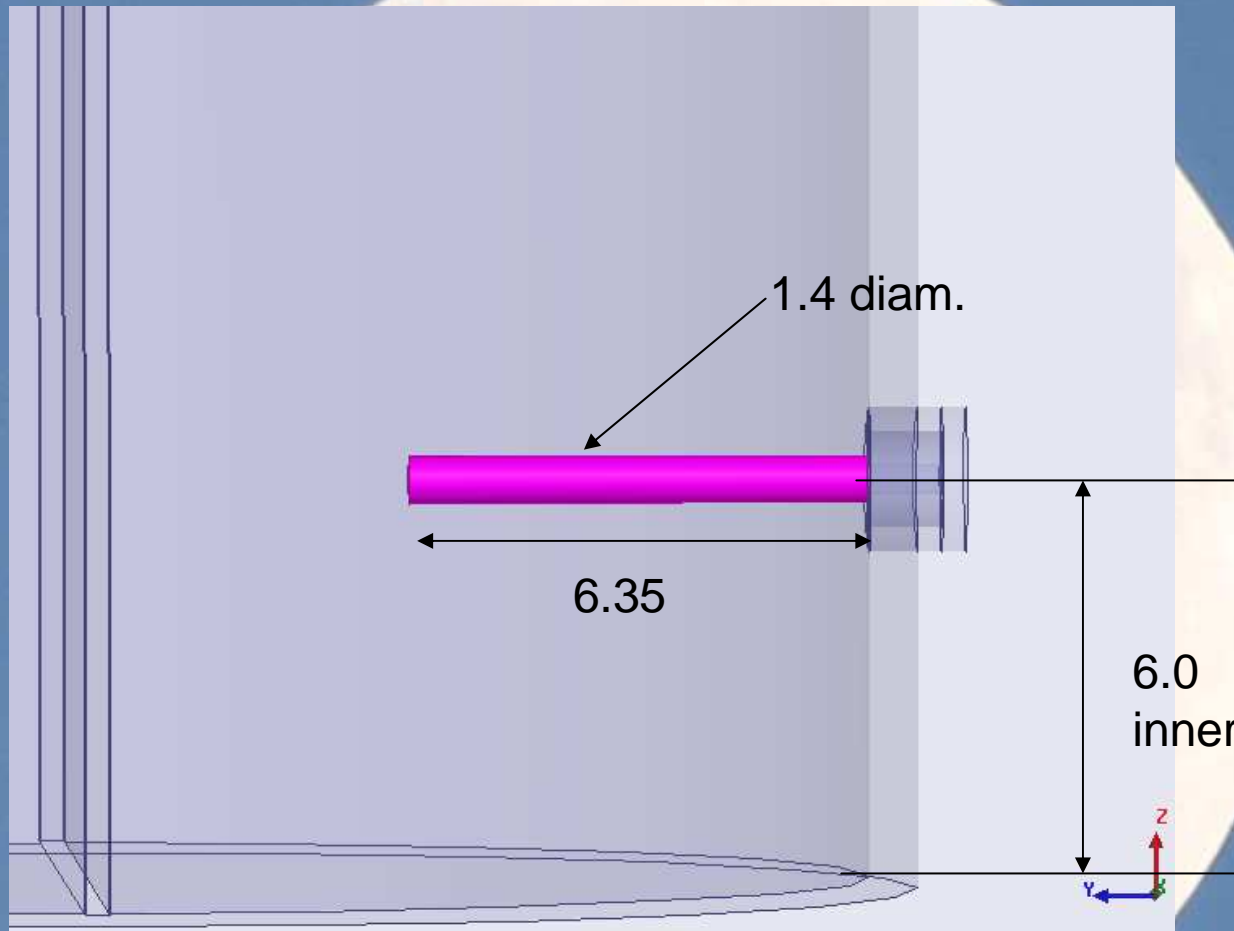

S11, S22, S21 combined

(3 cm 0.760 wl WG)

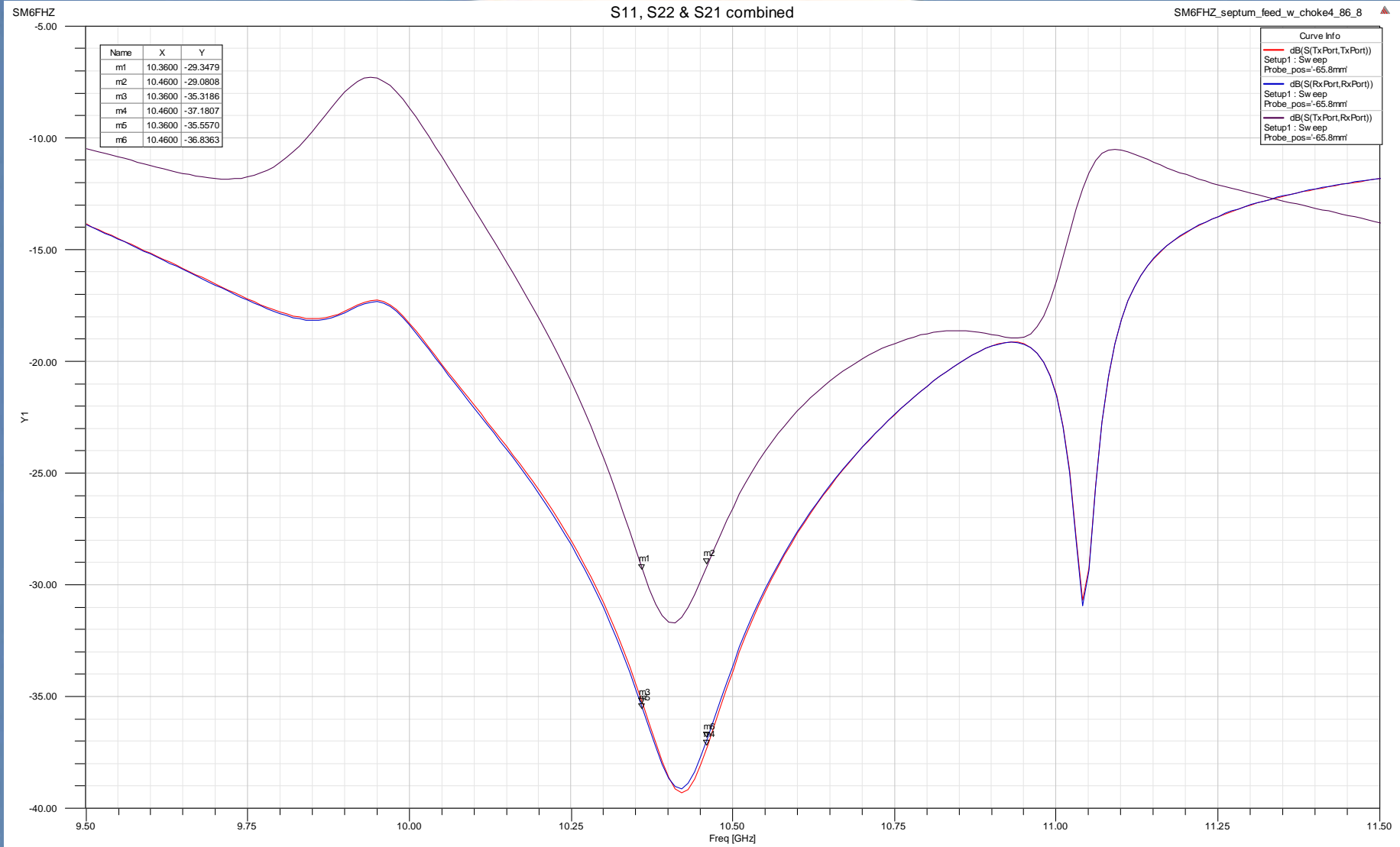

3D Total Power Far Field pattern

(3 cm 0.760 wl WG)

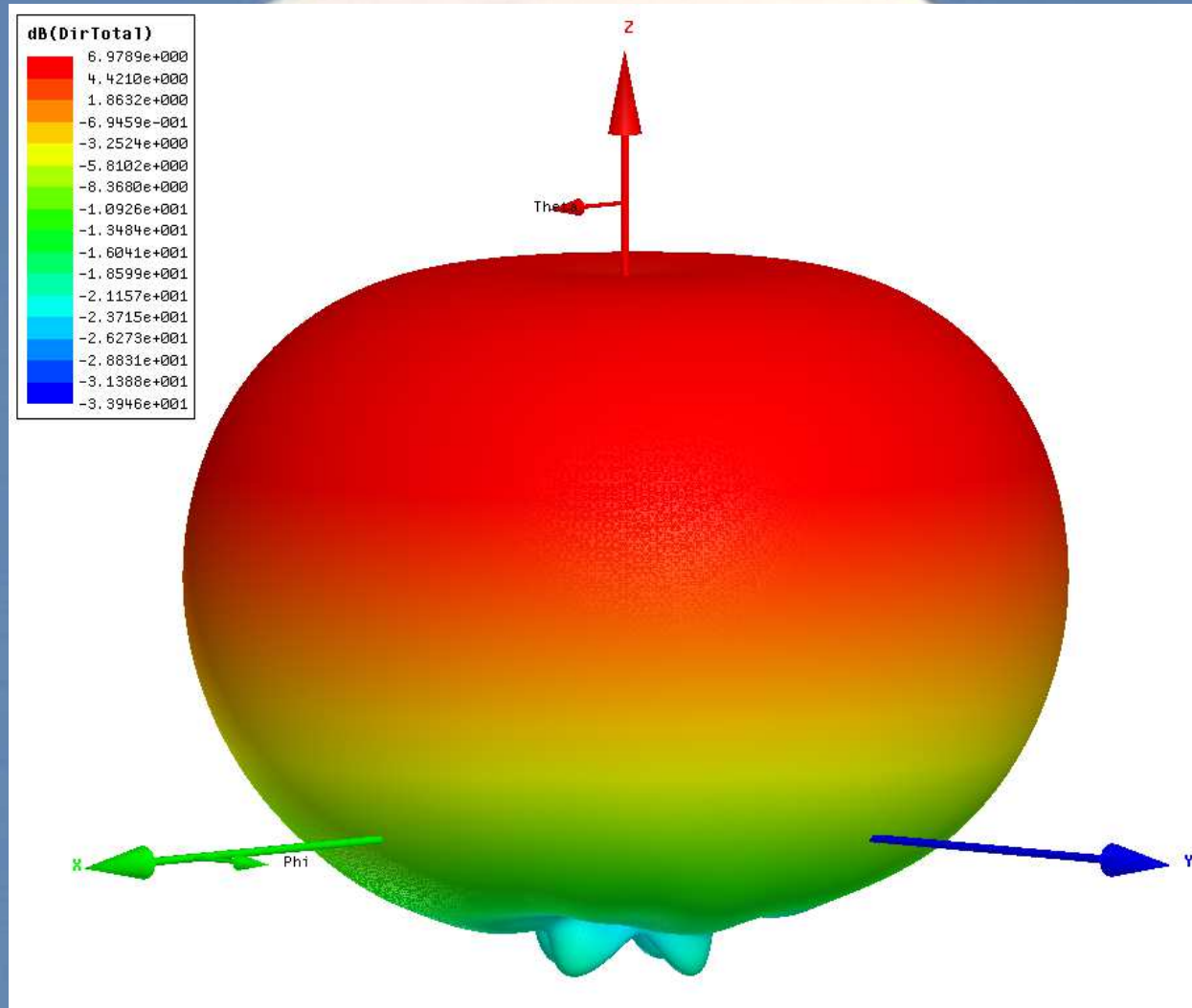

Far Field Pattern 0 deg (3 cm 0.760 wl WG)

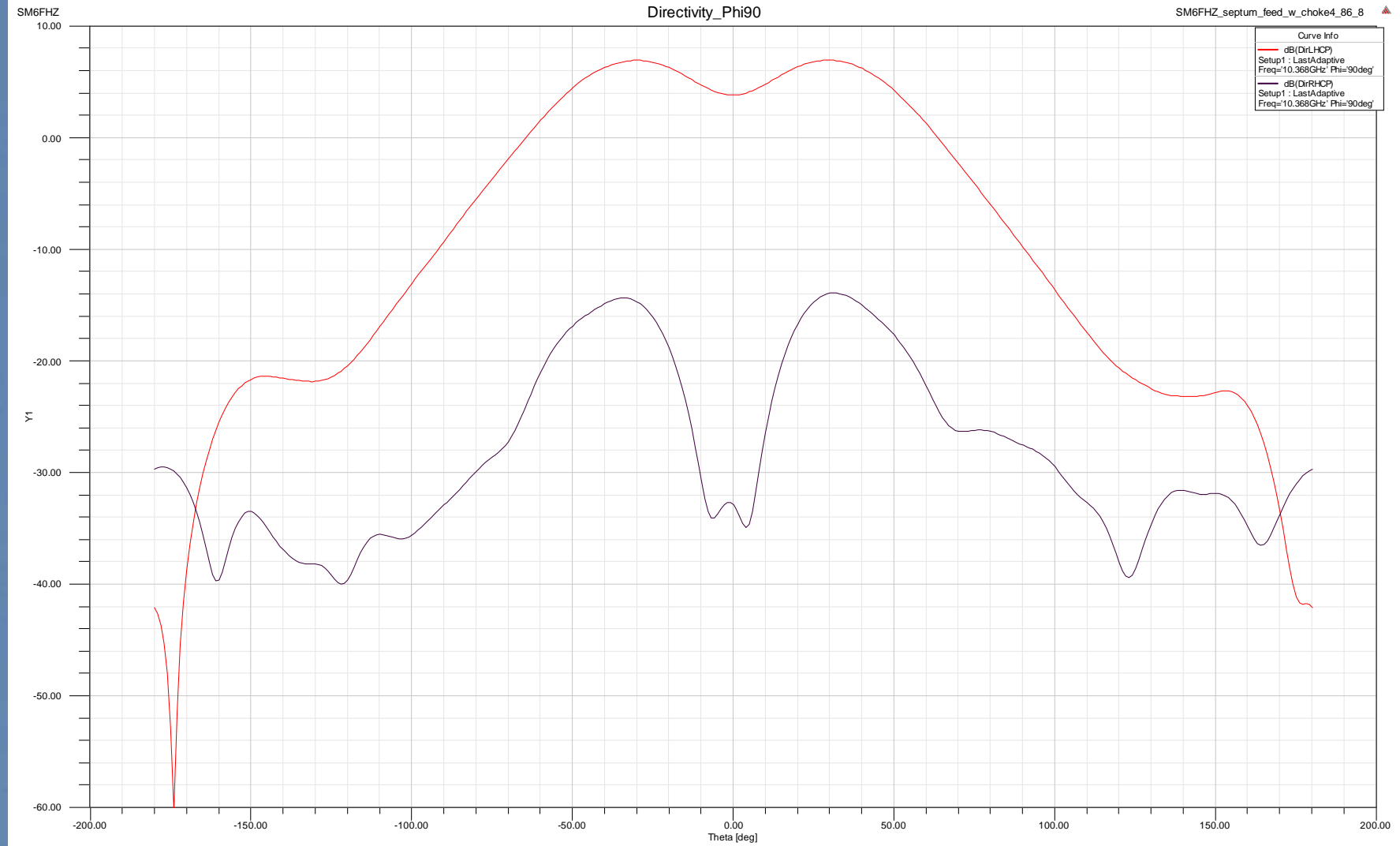

Far Field Phase error (3 cm 0.760 wl WG)

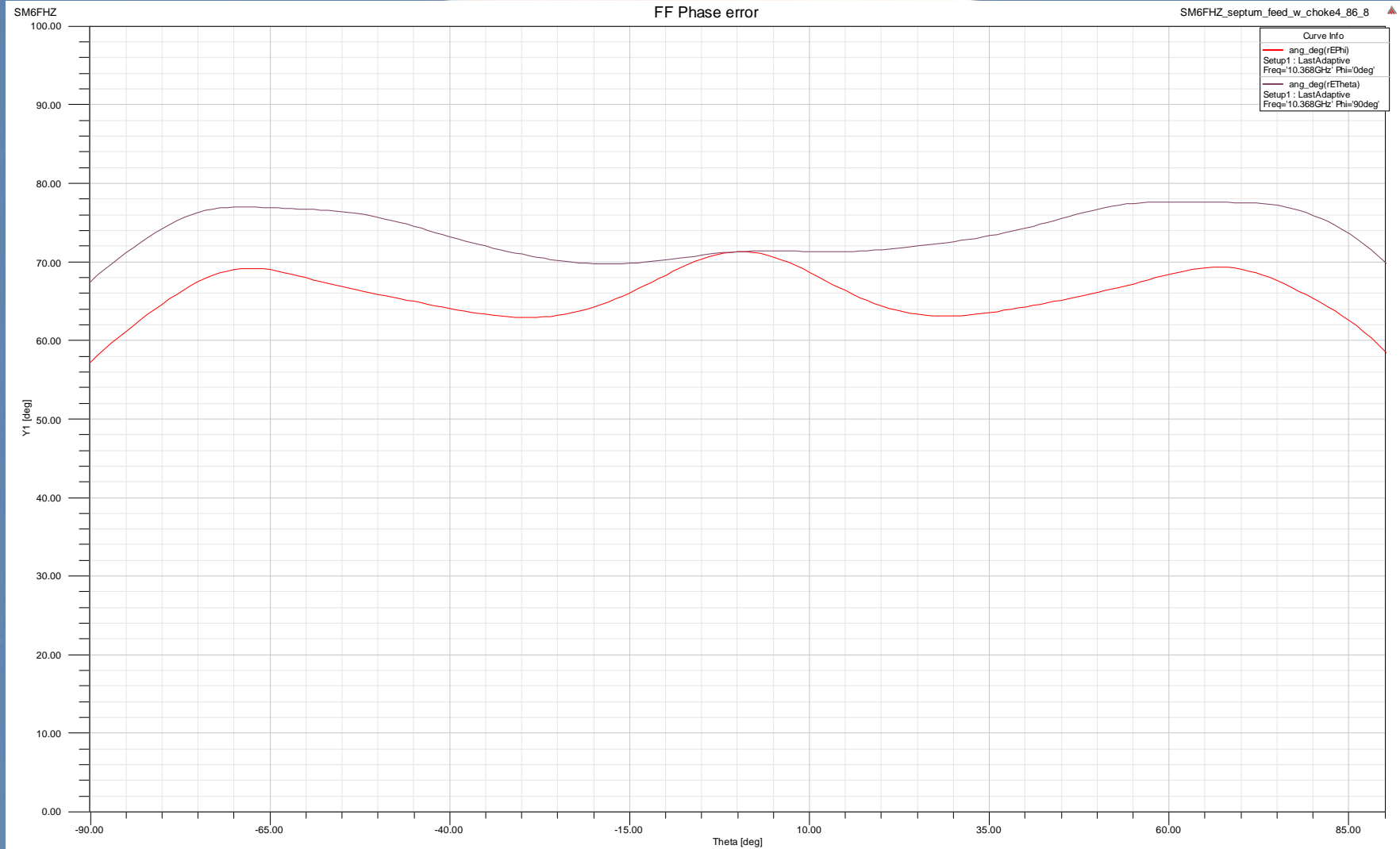

Cross Polar Ratio (3 cm 0.760 wl WG)

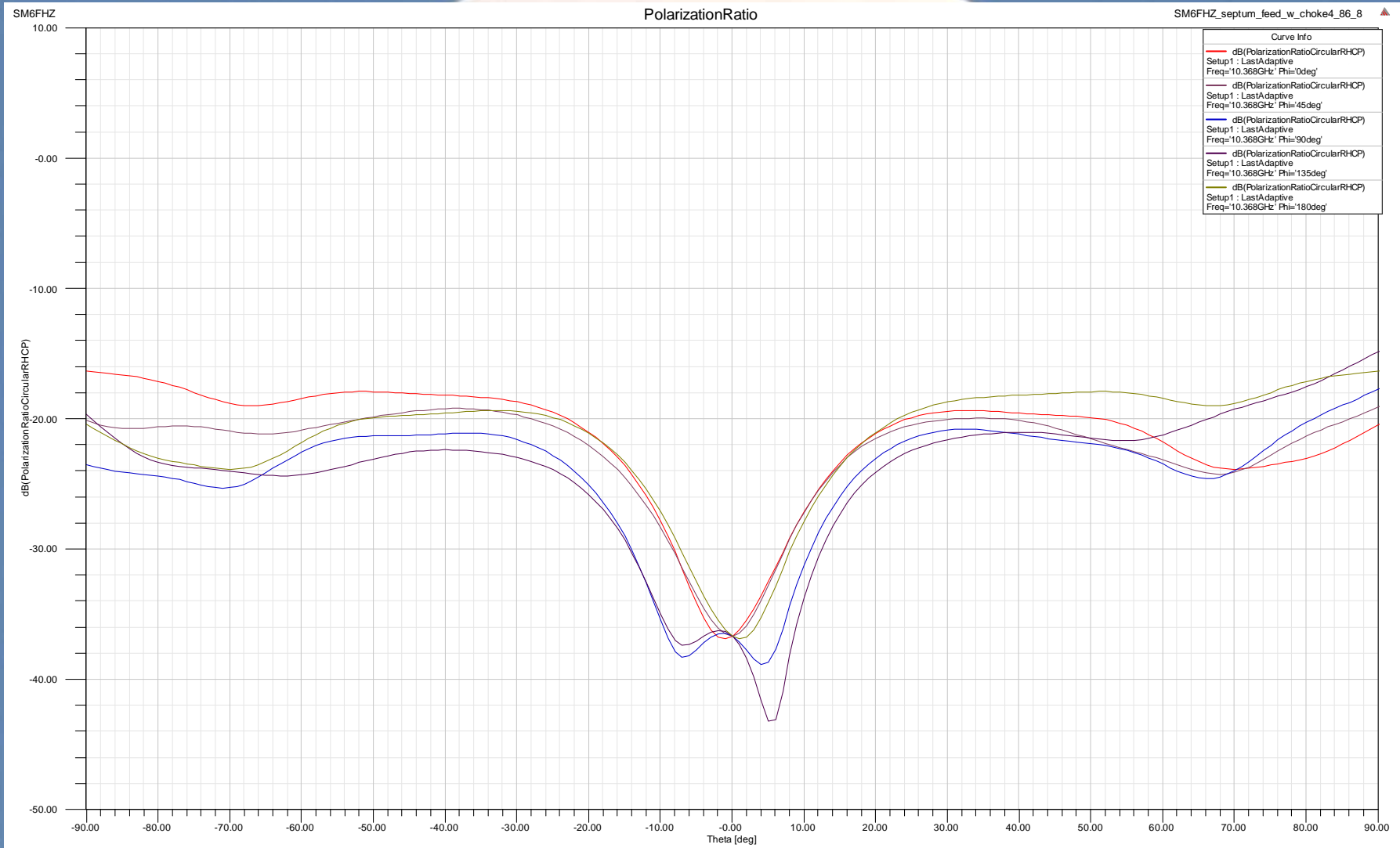

Axial Ratio (3 cm 0.760 wl WG)

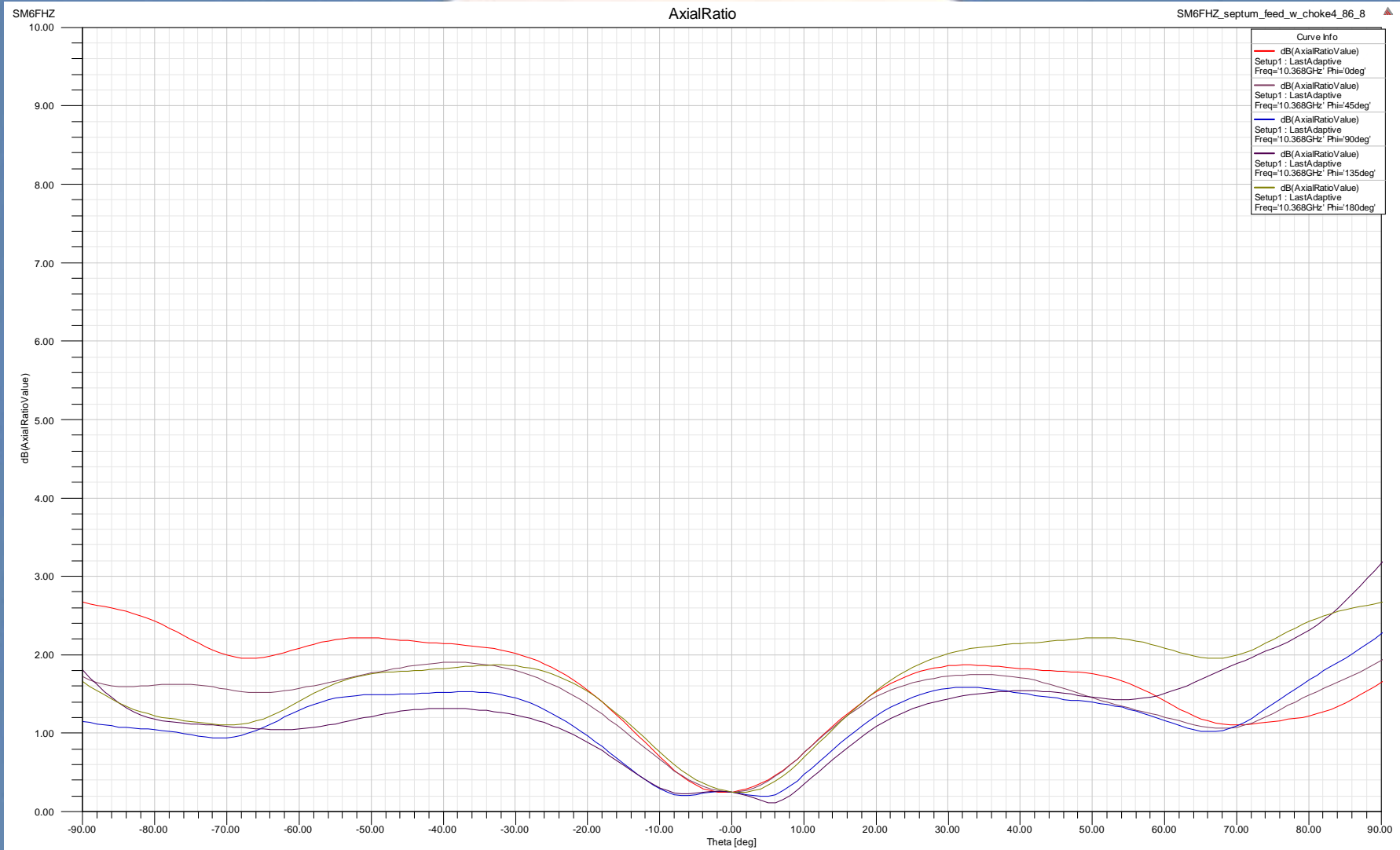



SM6FHZ 3 cm 5 step septum
feed for $f/D \sim 0.5$

0.760 lambda W/G
and a Dual Mode output section

Solid and transparent models from the simulation (3 cm 0.760 wl WG Dual Mode 39mm)

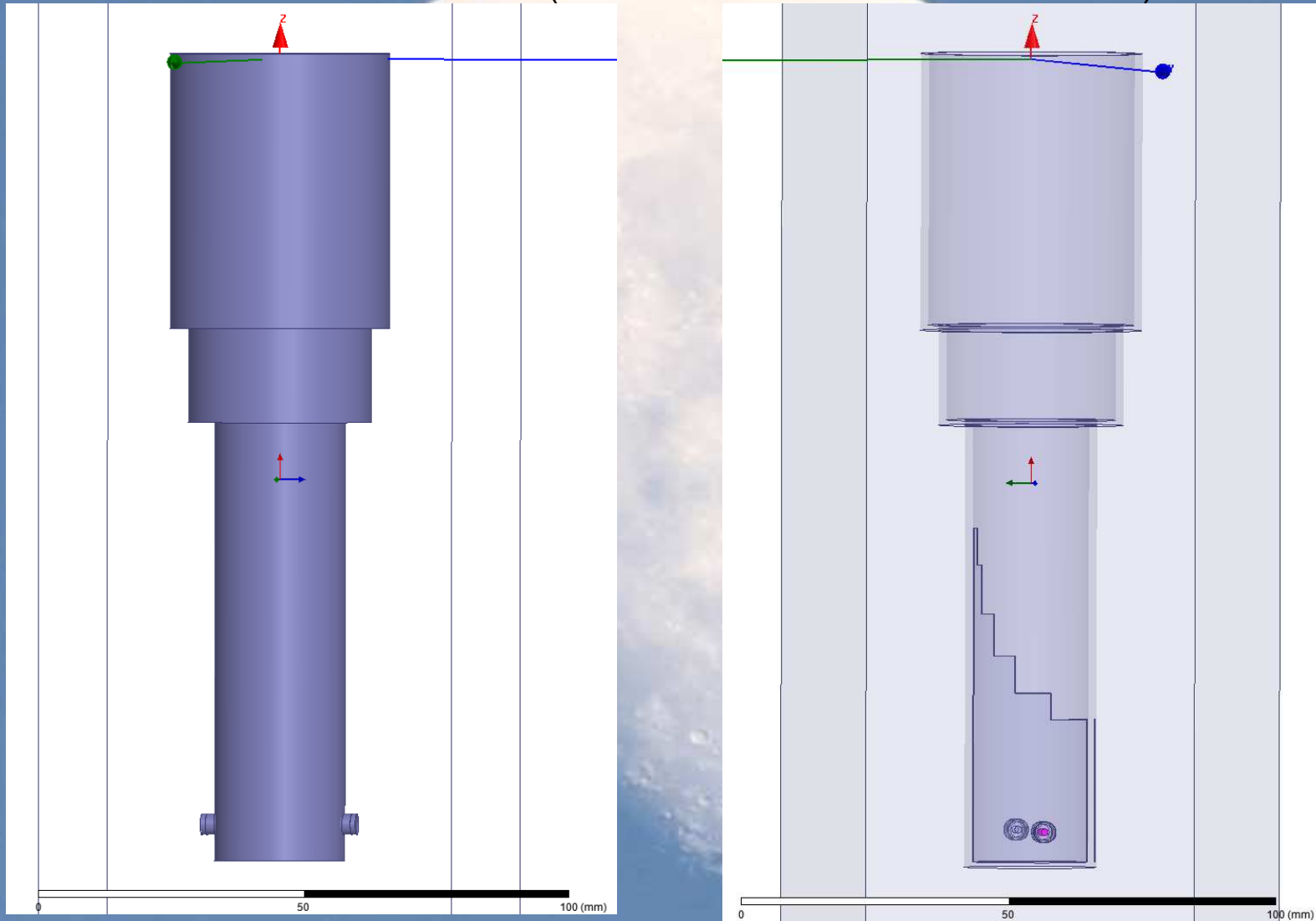

WG and choke dimensions

(3 cm 0.760 wl WG Dual Mode 39mm)

Circular polarization convention for EME according to Crawford Hill Bulletin No 1:

Tx RHCP in space
Rx LHCP in space

Take polarization reversal into account when using reflector antennas.

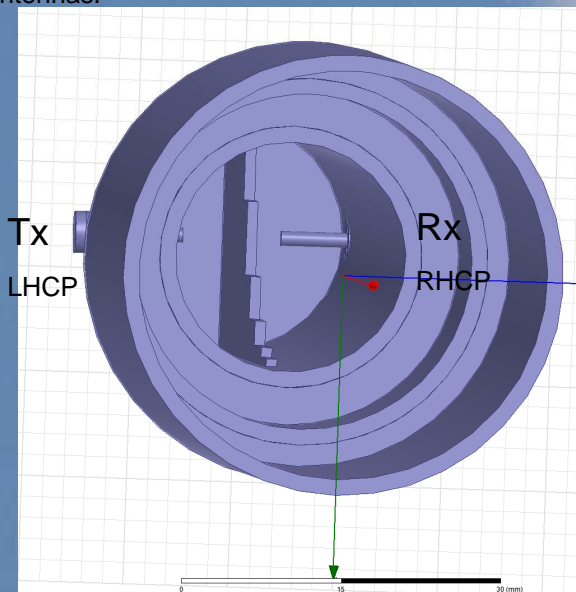

SM6FHZ 2015-05-26
Rev A

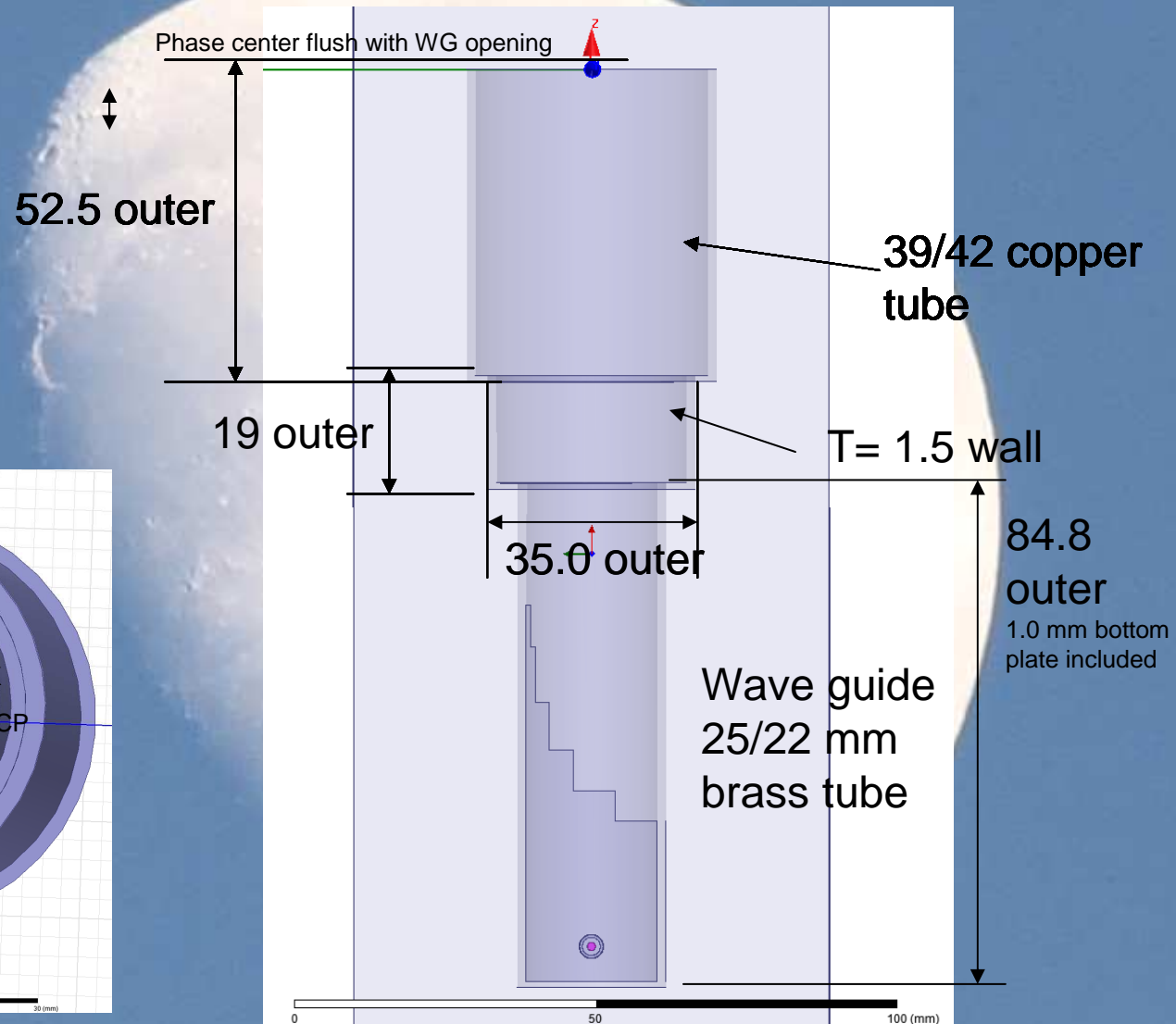

Swedish EME-meeting May 2015

Detail of WG / transformer and output section

(3 cm 0.760 wl WG Dual Mode 39mm)

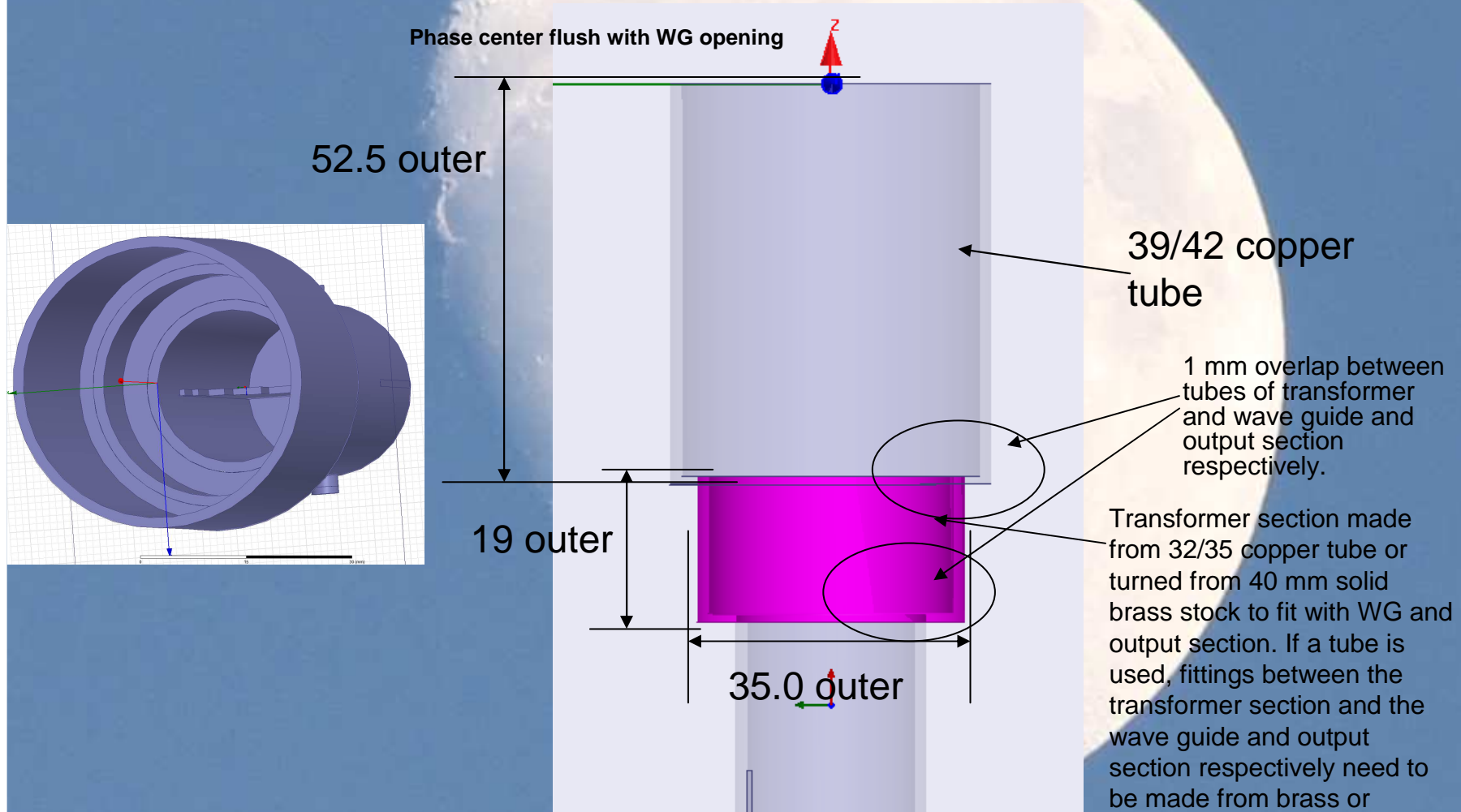

Septum dimensions

(3 cm 0.760 wl WG Dual Mode 39mm)

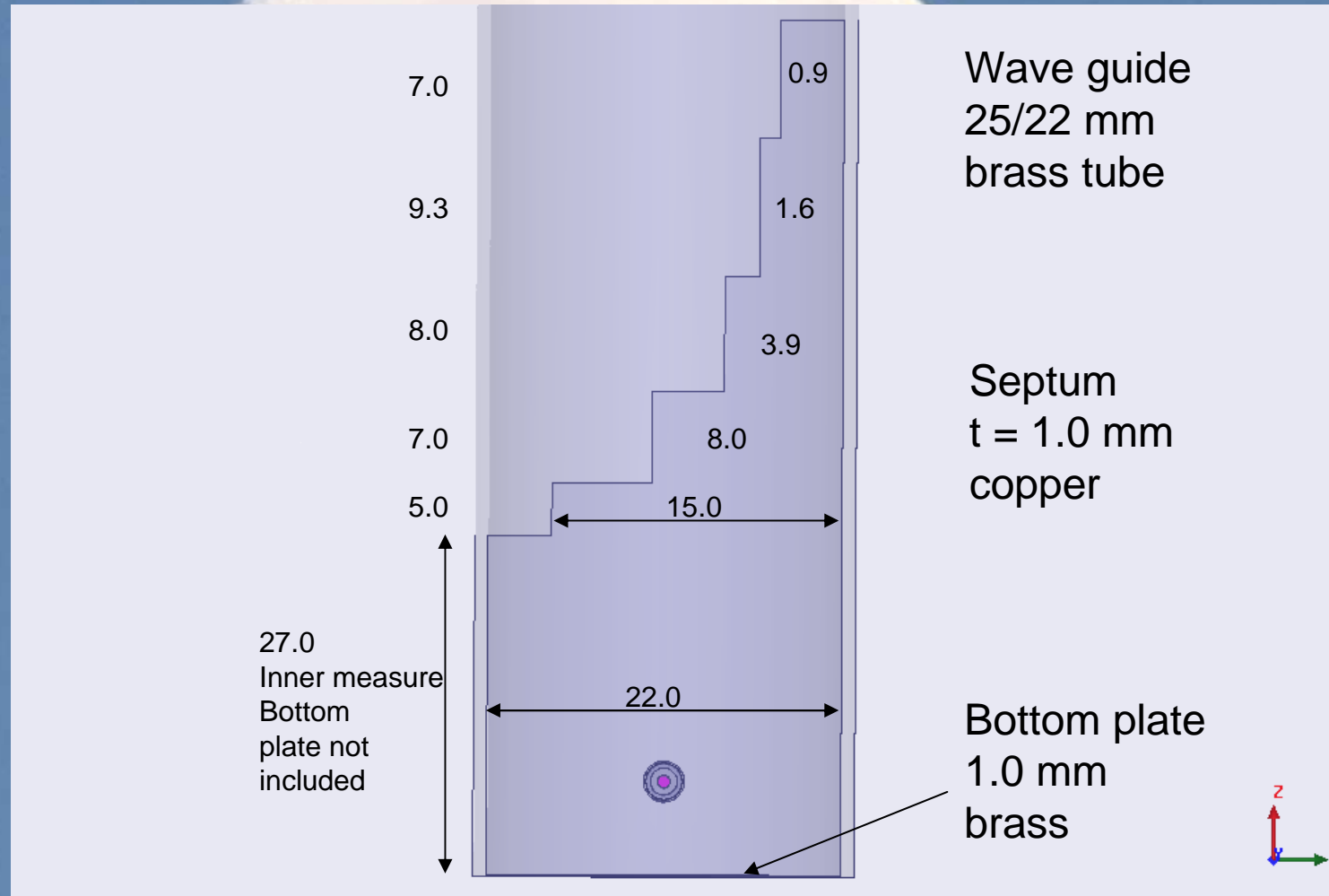

Probe dimensions (3 cm 0.760 wl WG Dual Mode 39mm)

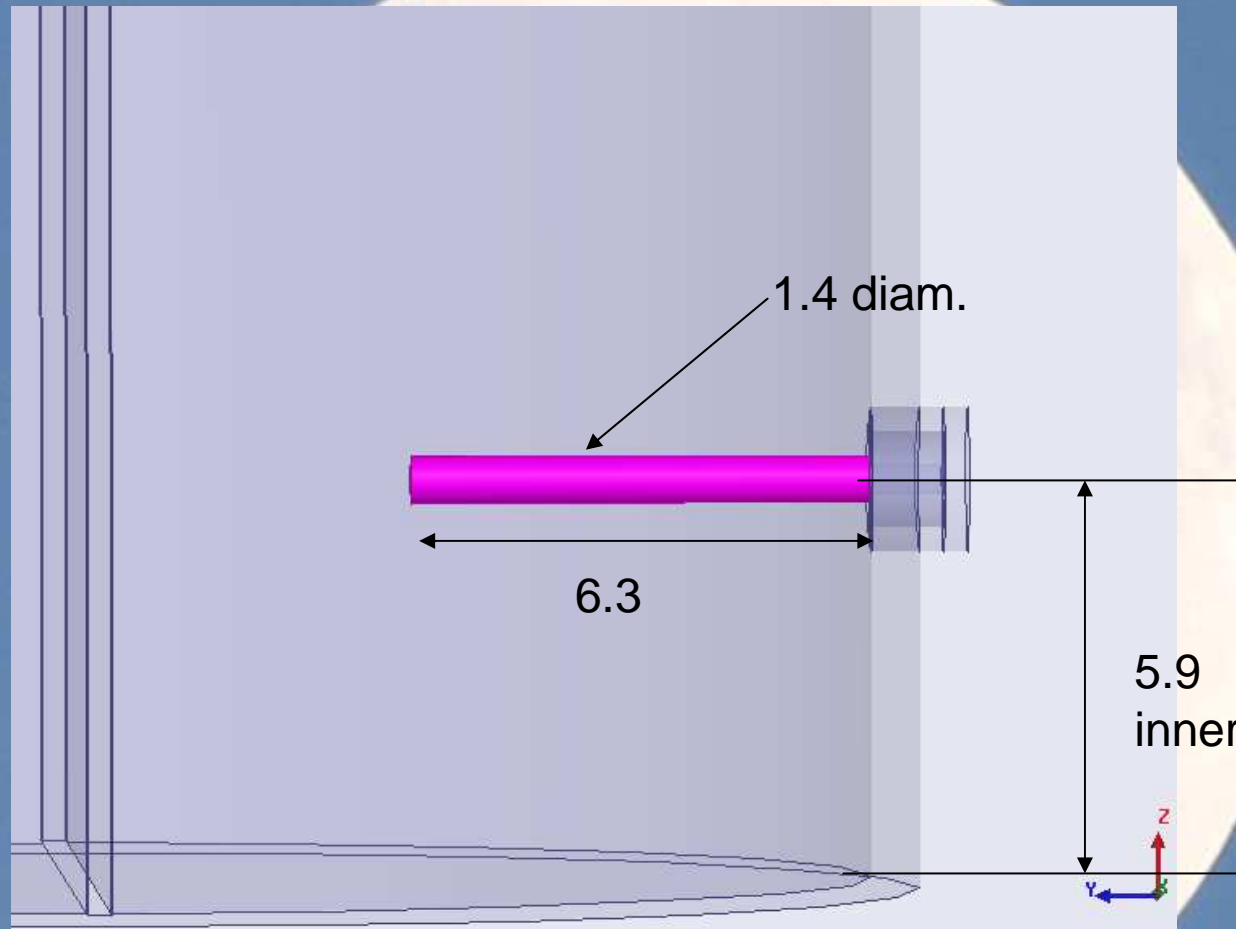

InDish performance

SM6FHZ 3 cm Dual Mode Feed

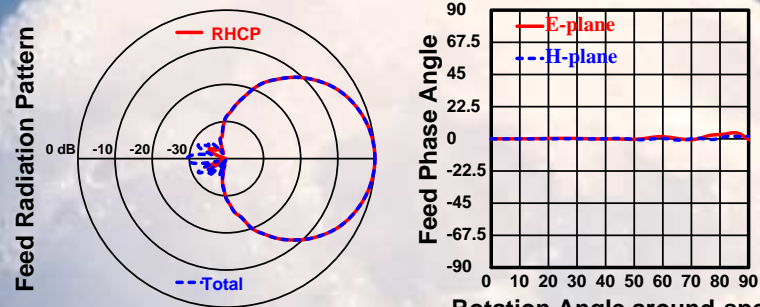

Dish diameter = 190λ Feed diameter = 10λ

Rotation Angle around specified Phase Center = 0.006λ beyond aperture

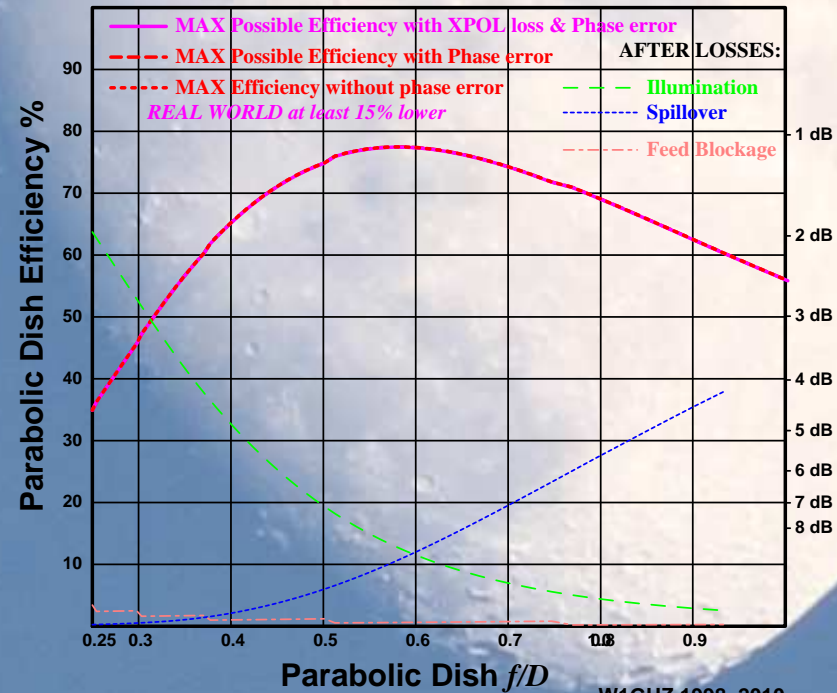

W1GHZ 1998, 2010

S11, S22, S21 combined

(3 cm 0.760 wl WG Dual Mode 39mm)

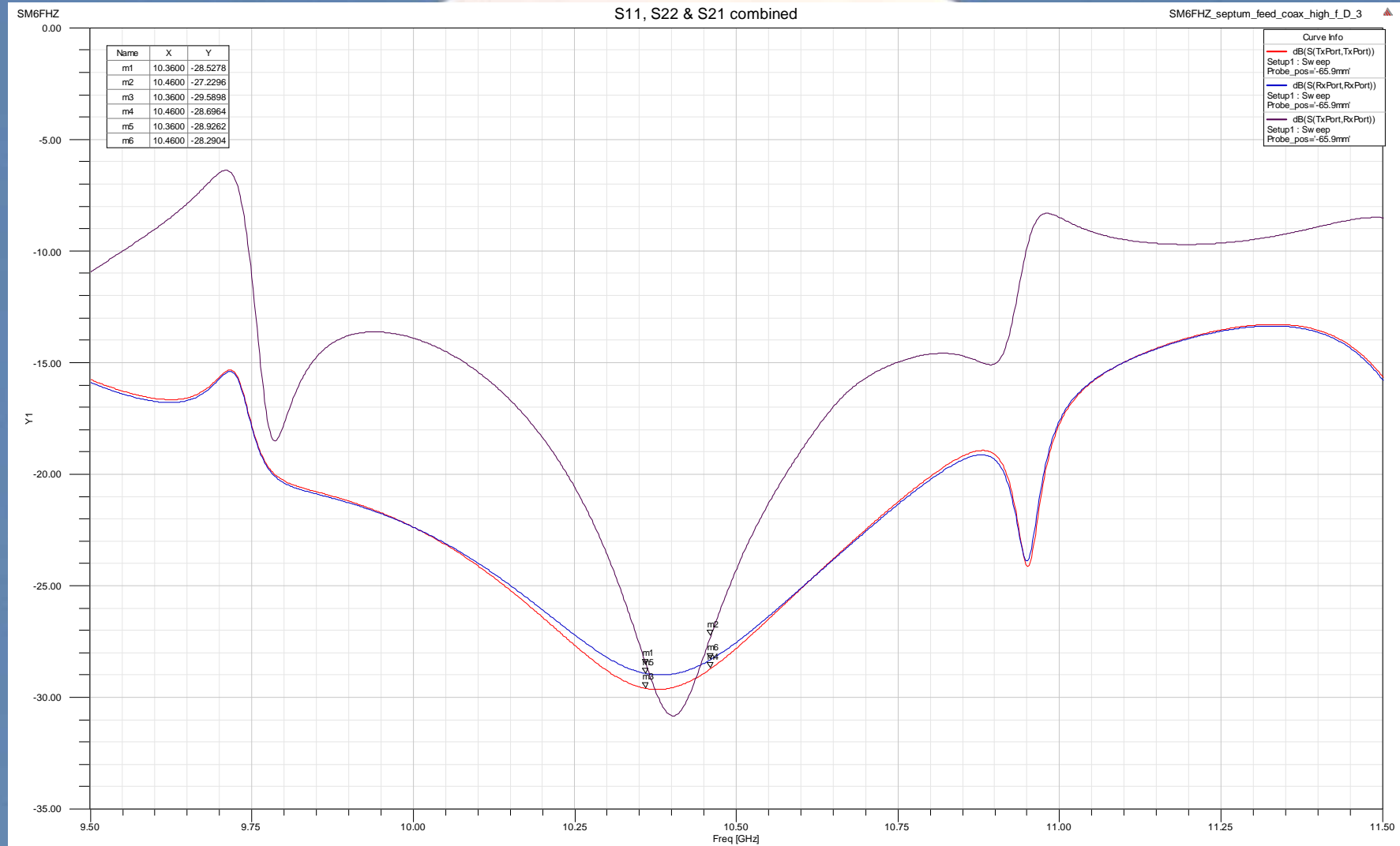

3D Total Power Far Field pattern

(3 cm 0.760 wl WG Dual Mode 39mm)

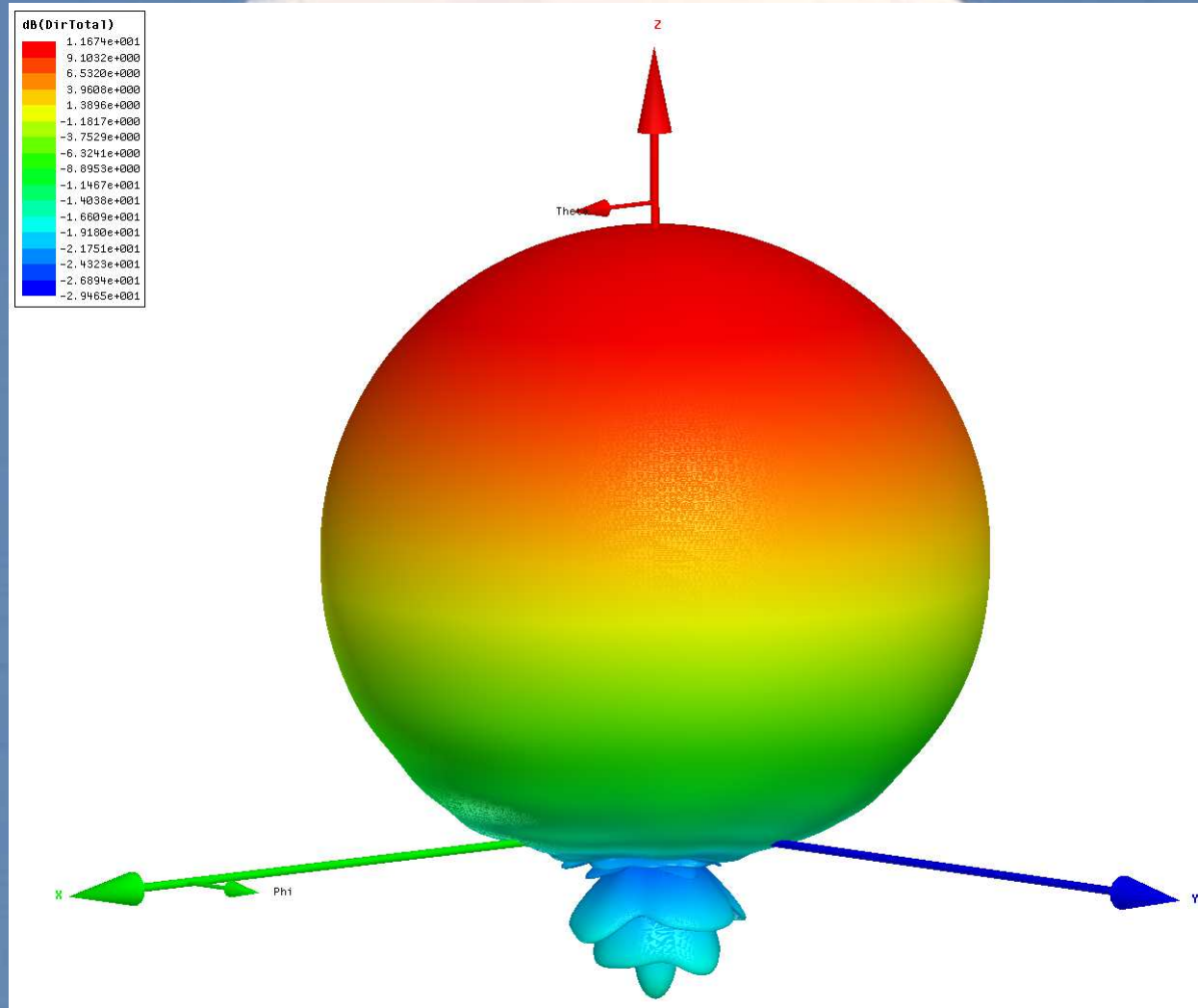

Far Field Pattern 0 deg

(3 cm 0.760 wl WG Dual Mode 39mm)

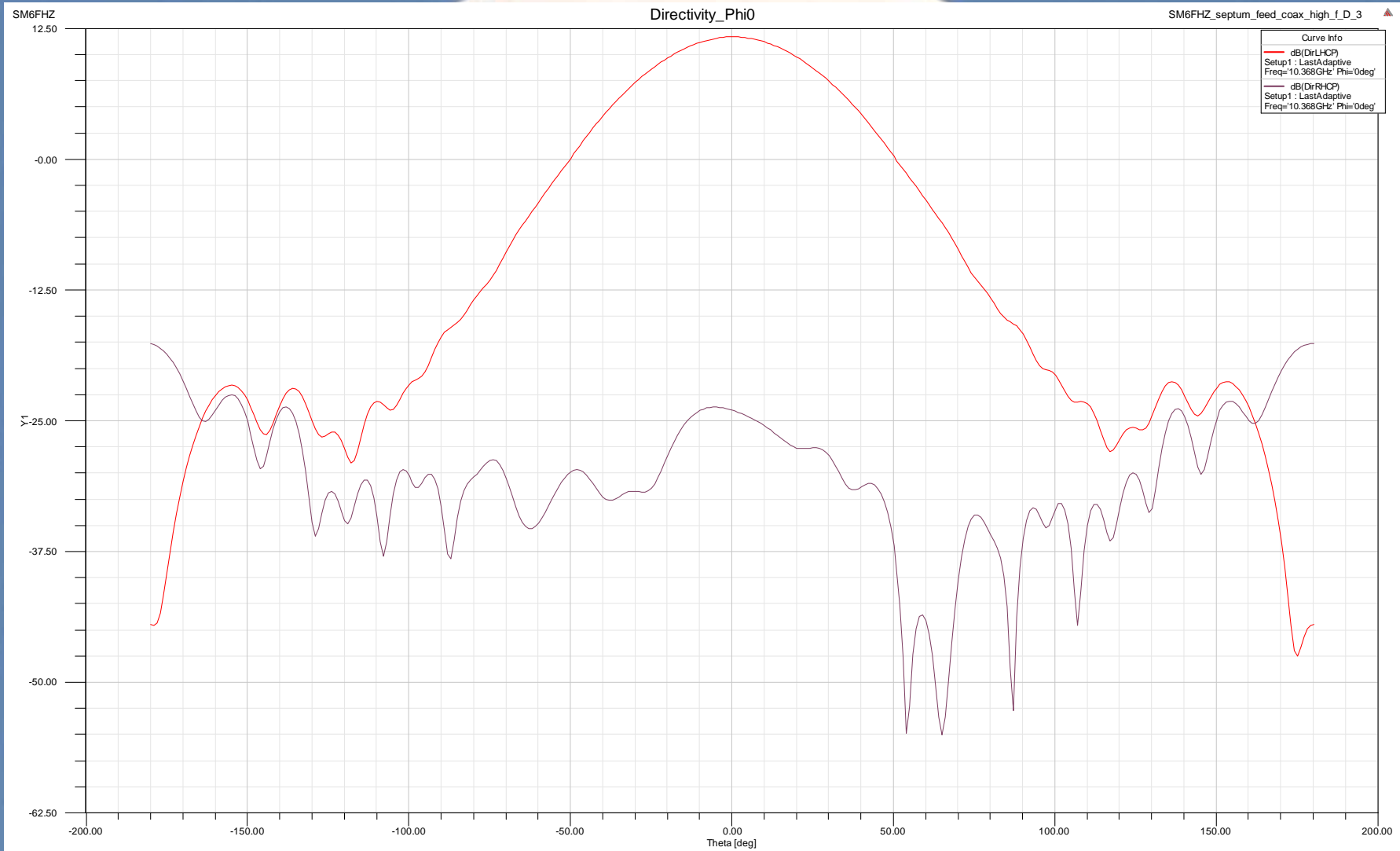

Far Field Phase error

(3 cm 0.760 wl WG Dual Mode 39mm)

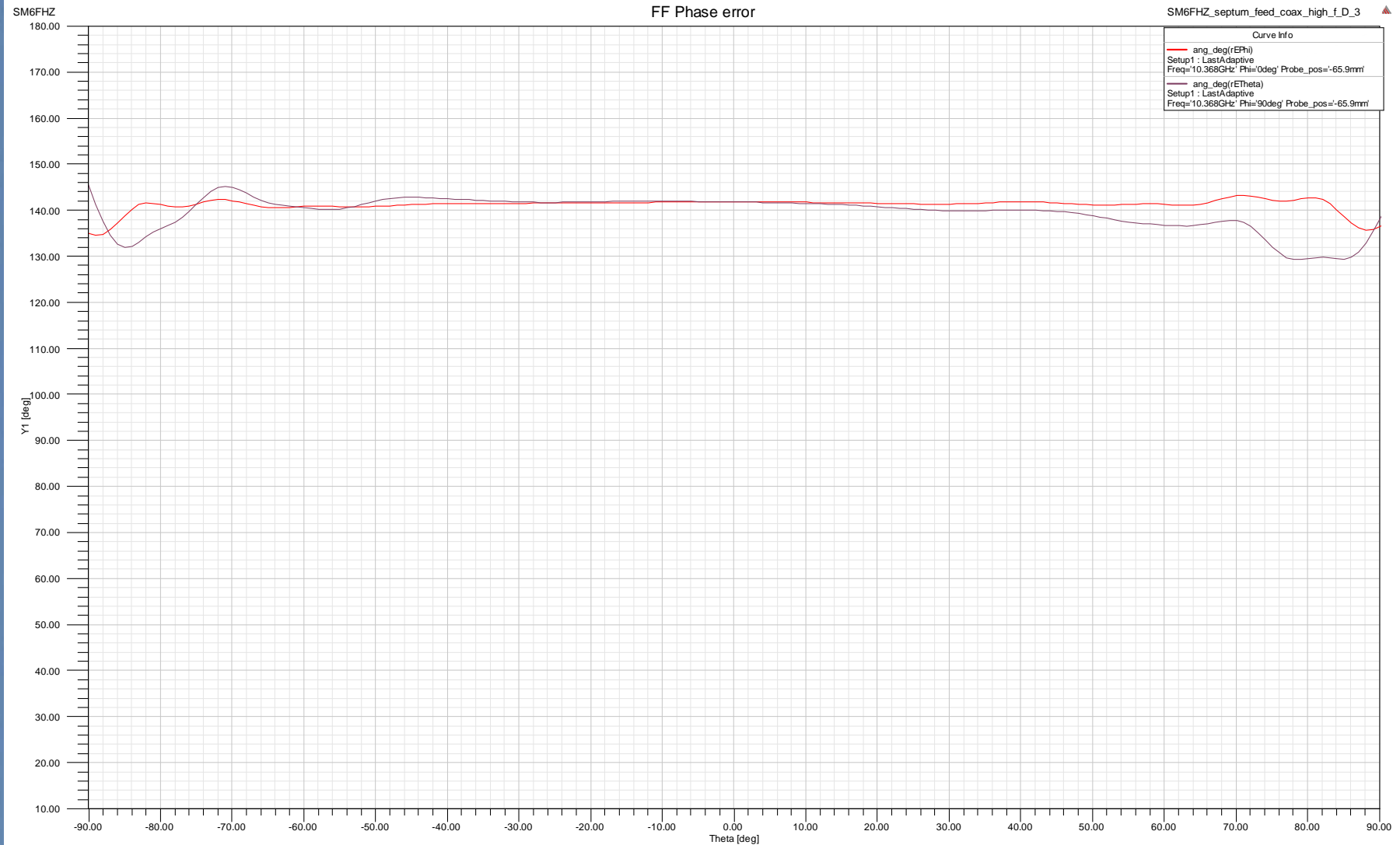

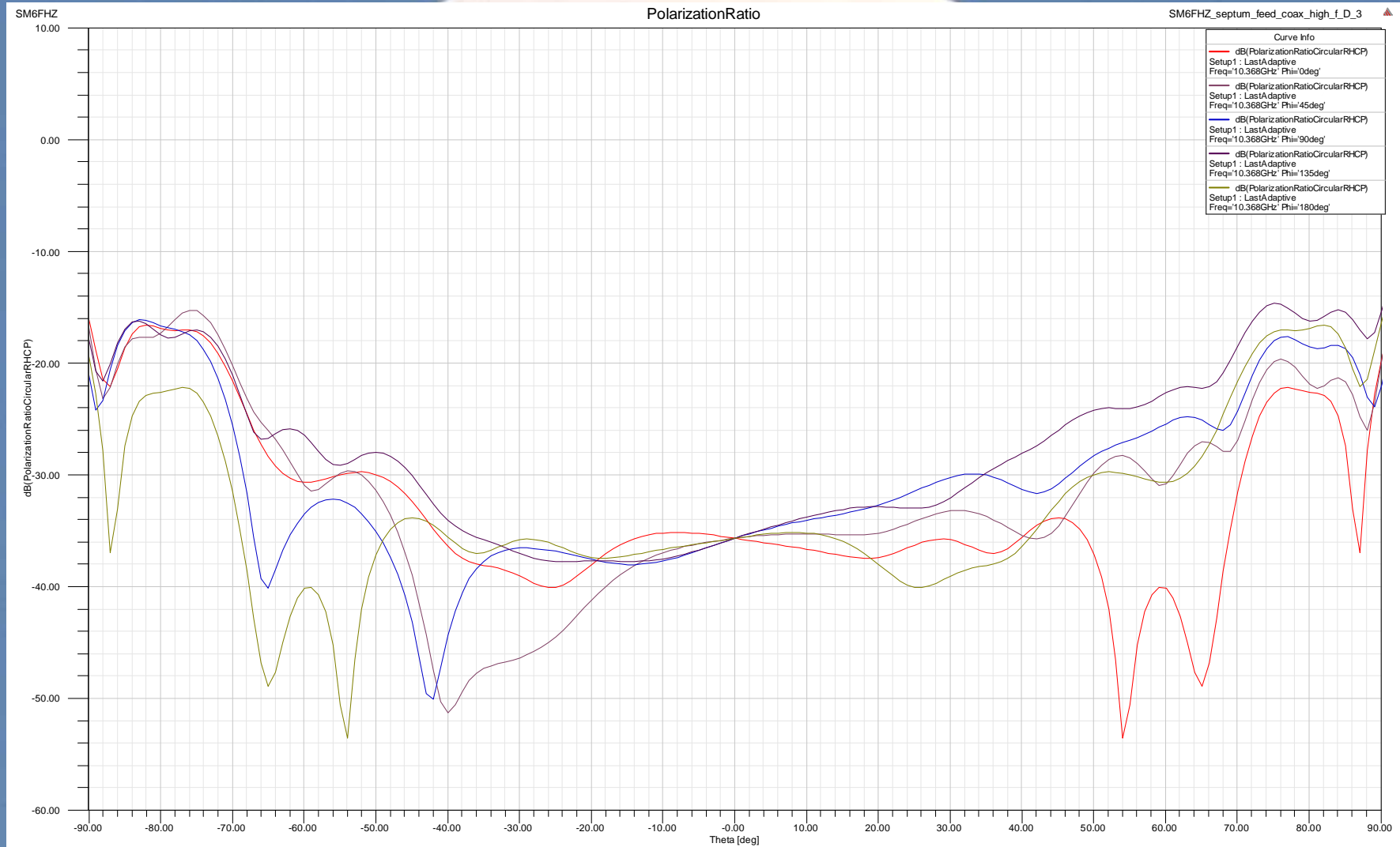

Cross Polar Ratio

(3 cm 0.760 wl WG Dual Mode 39mm)

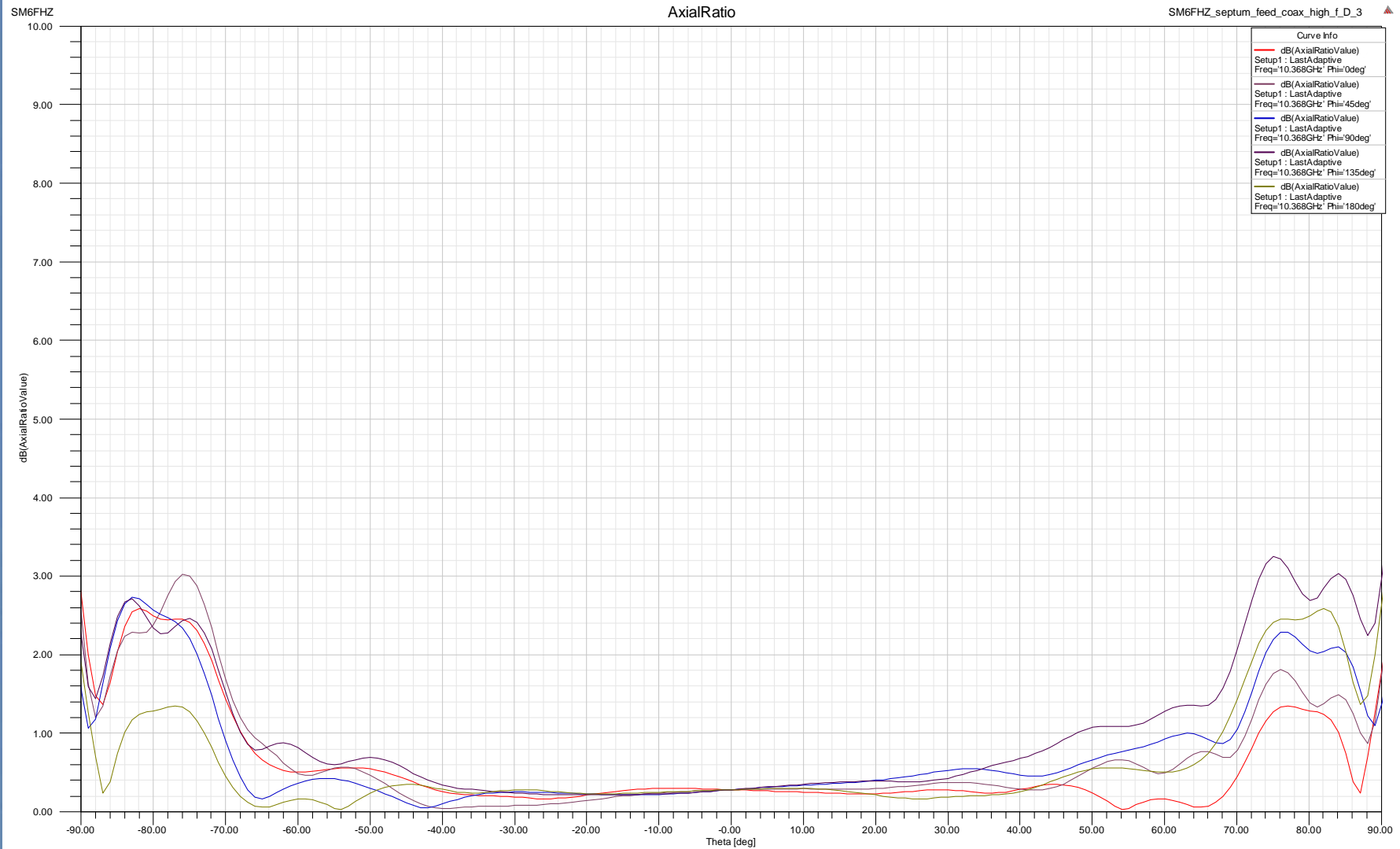

Axial Ratio (3 cm 0.760 wl WG Dual Mode 39mm)





SM6FHZ 3 cm 5 step septum
feed

0.760 lambda W/G

Using standard one inch brass / copper tubing

Solid and transparent models from the simulation (3 cm 0.760 wl WG inch tube)

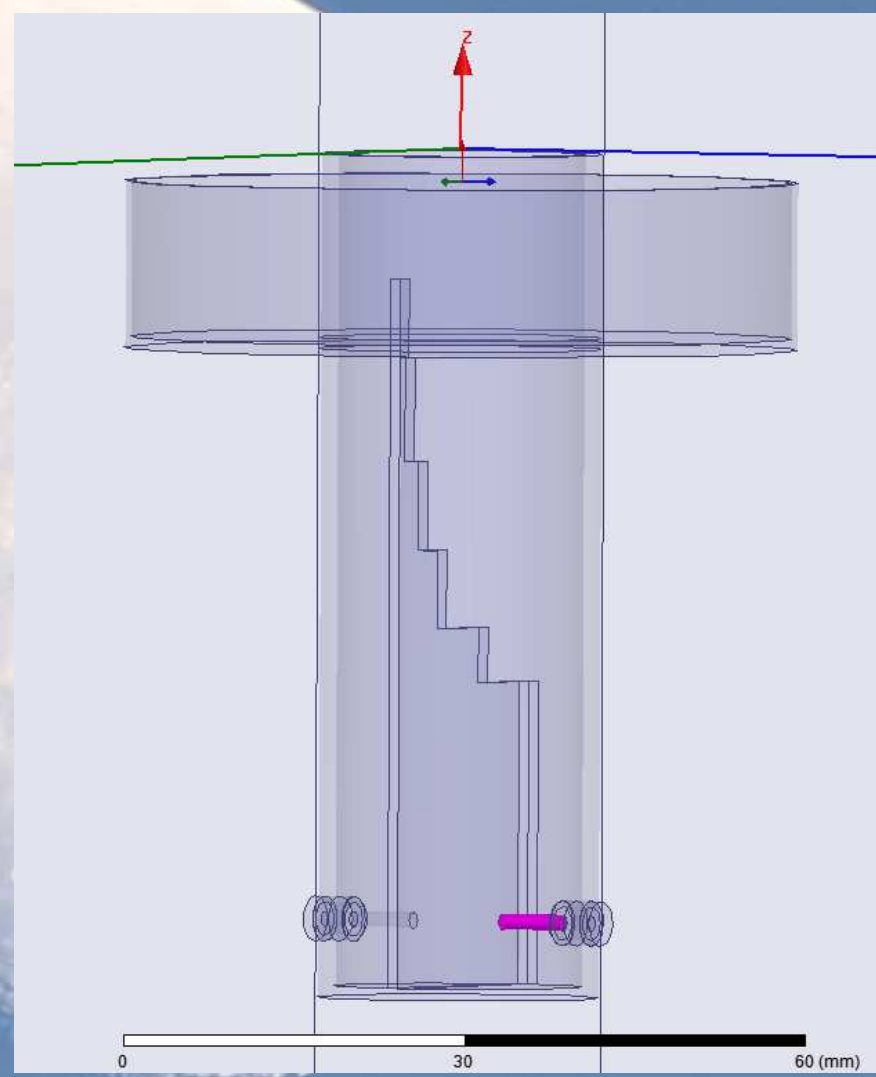
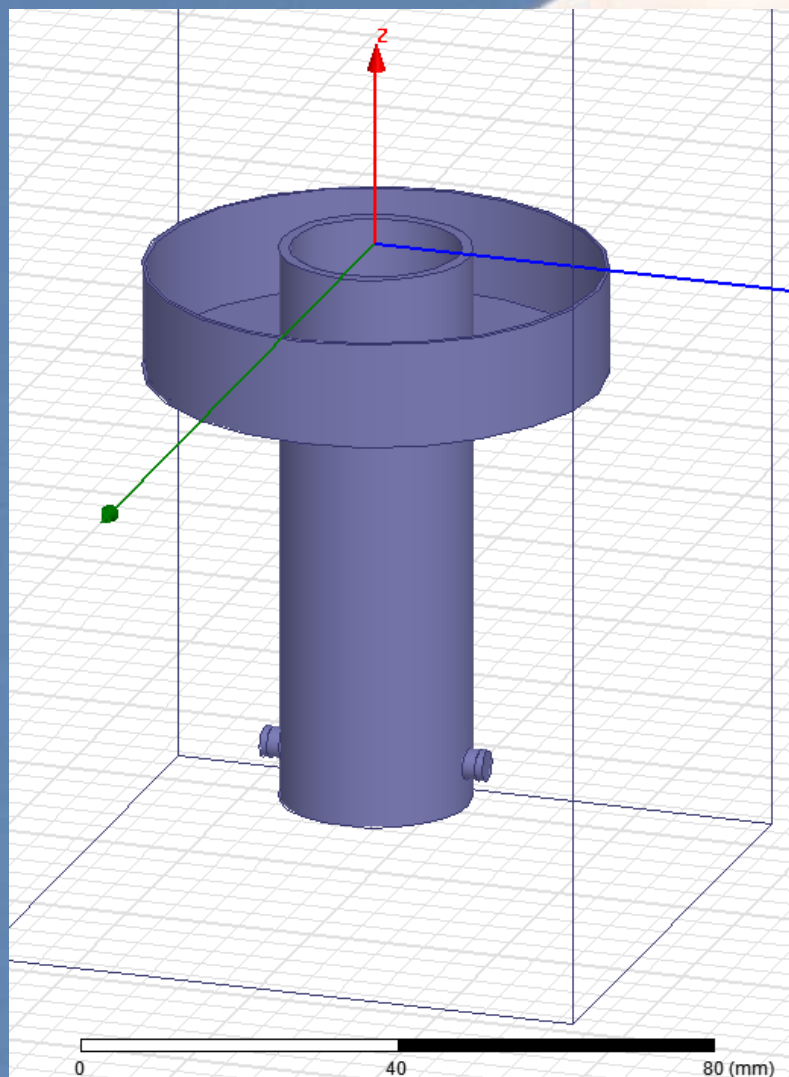

WG and choke dimensions

(3 cm 0.760 wl WG inch tube)

Circular polarization convention for EME according to Crawford Hill Bulletin No 1:

Tx RHCP in space
Rx LHCP in space

Take polarization reversal into account when using reflector antennas.

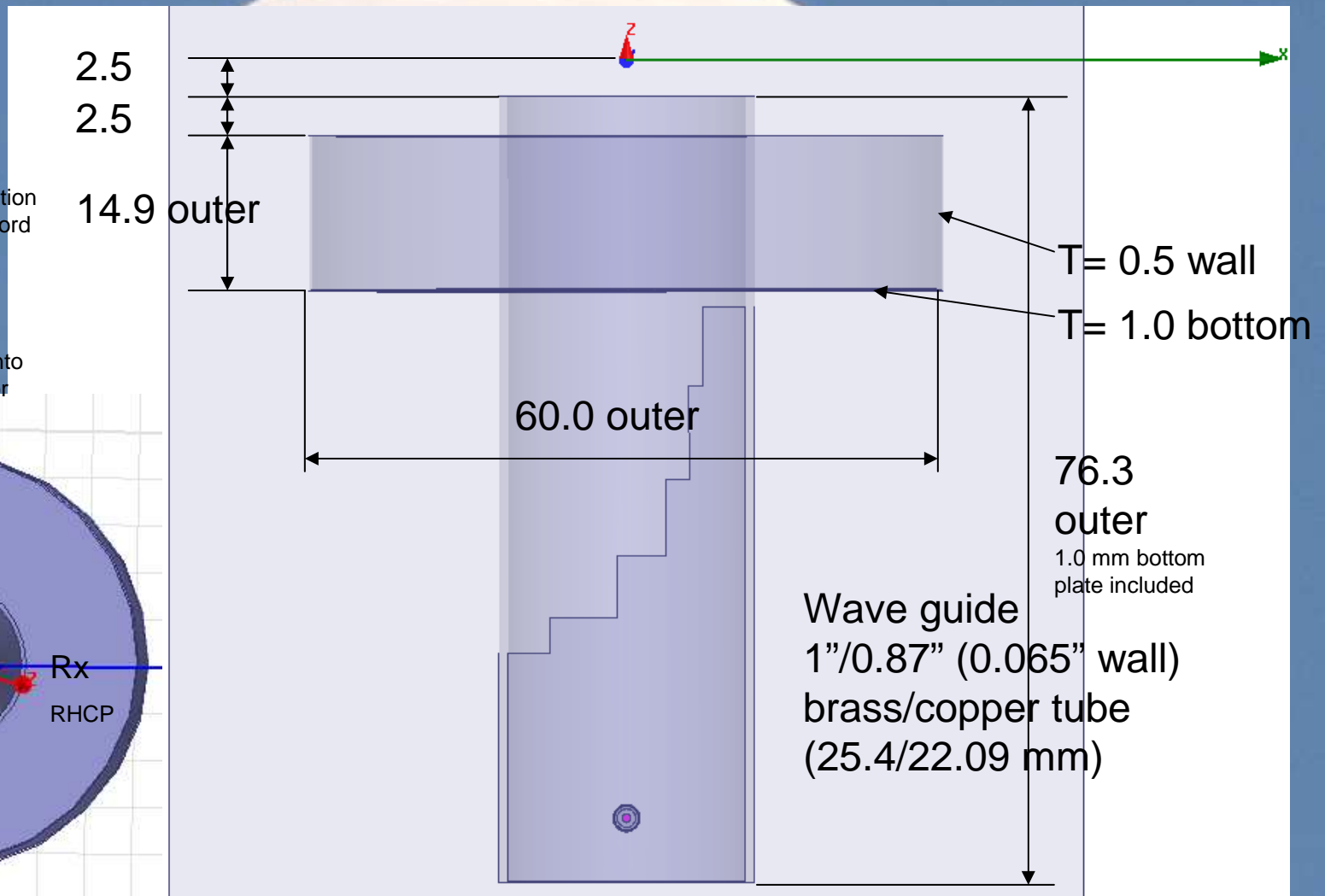
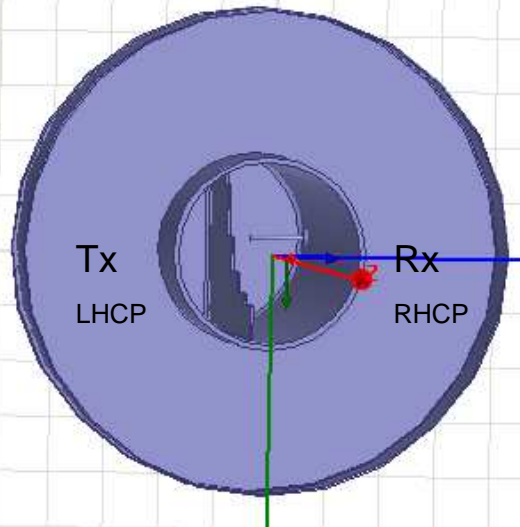

Septum dimensions

(3 cm 0.760 wl WG inch tube)

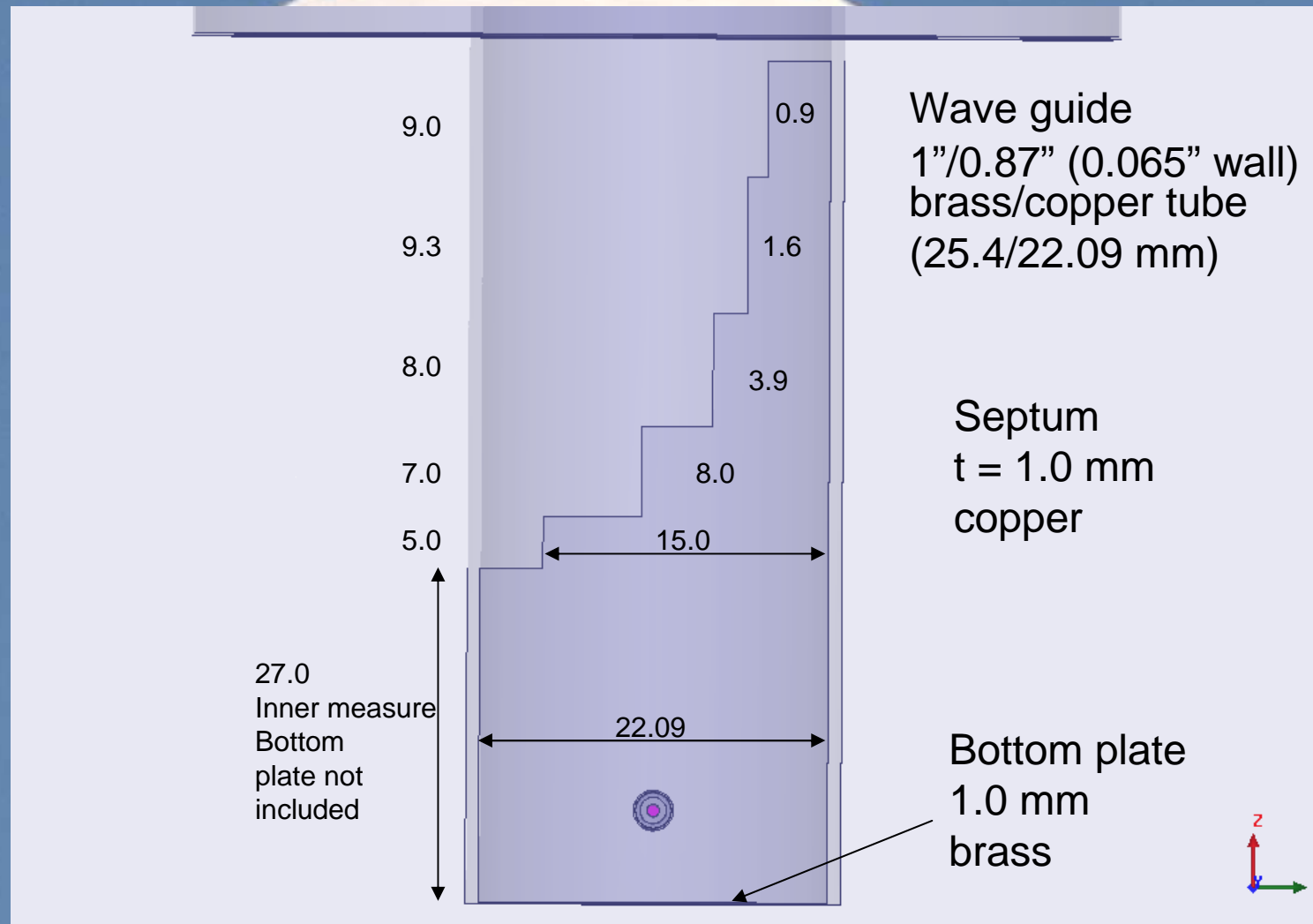

Probe dimensions (3 cm 0.760 wI WG inch tube)

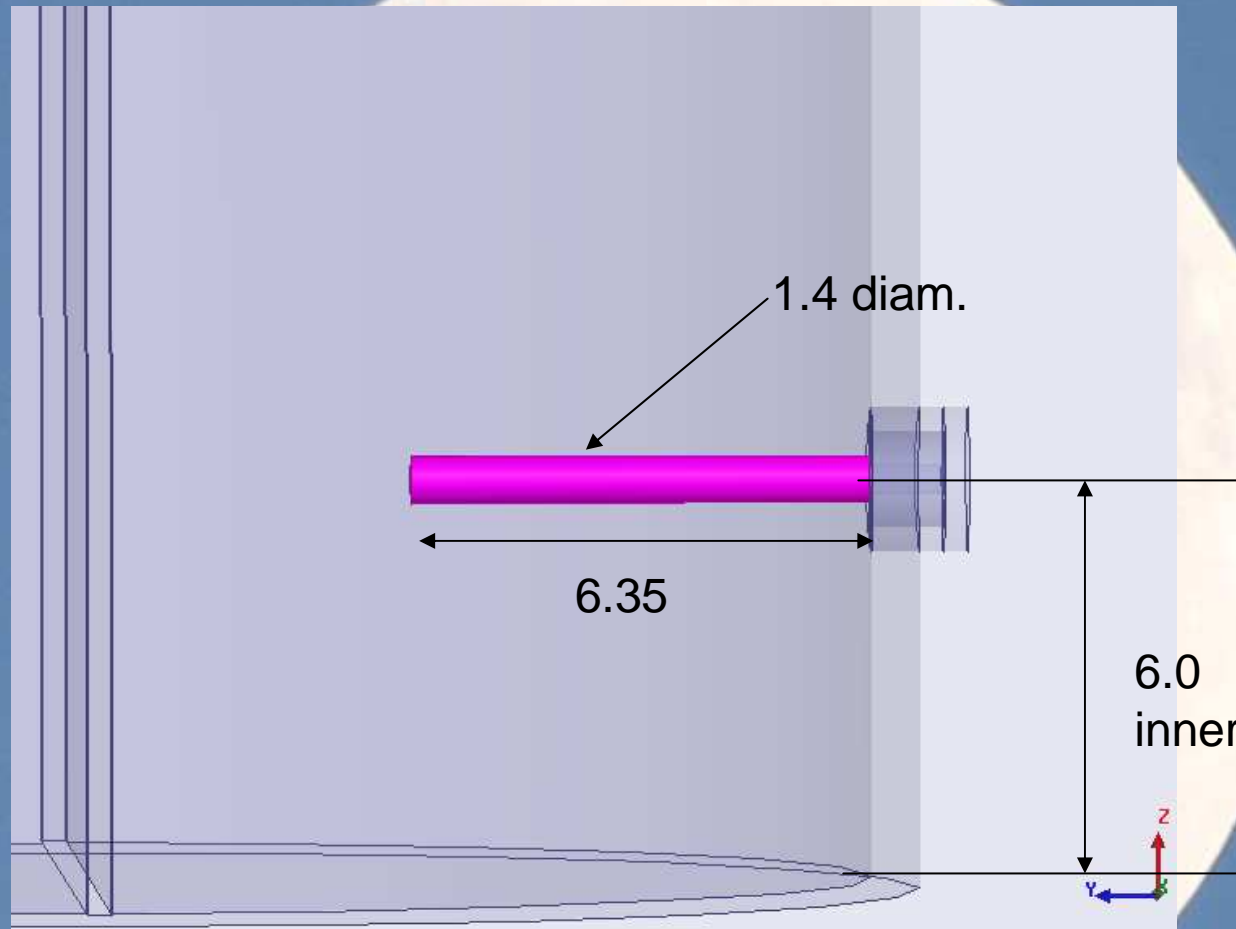

S11, S22, S21 combined

(3 cm 0.760 wl WG inch tube)

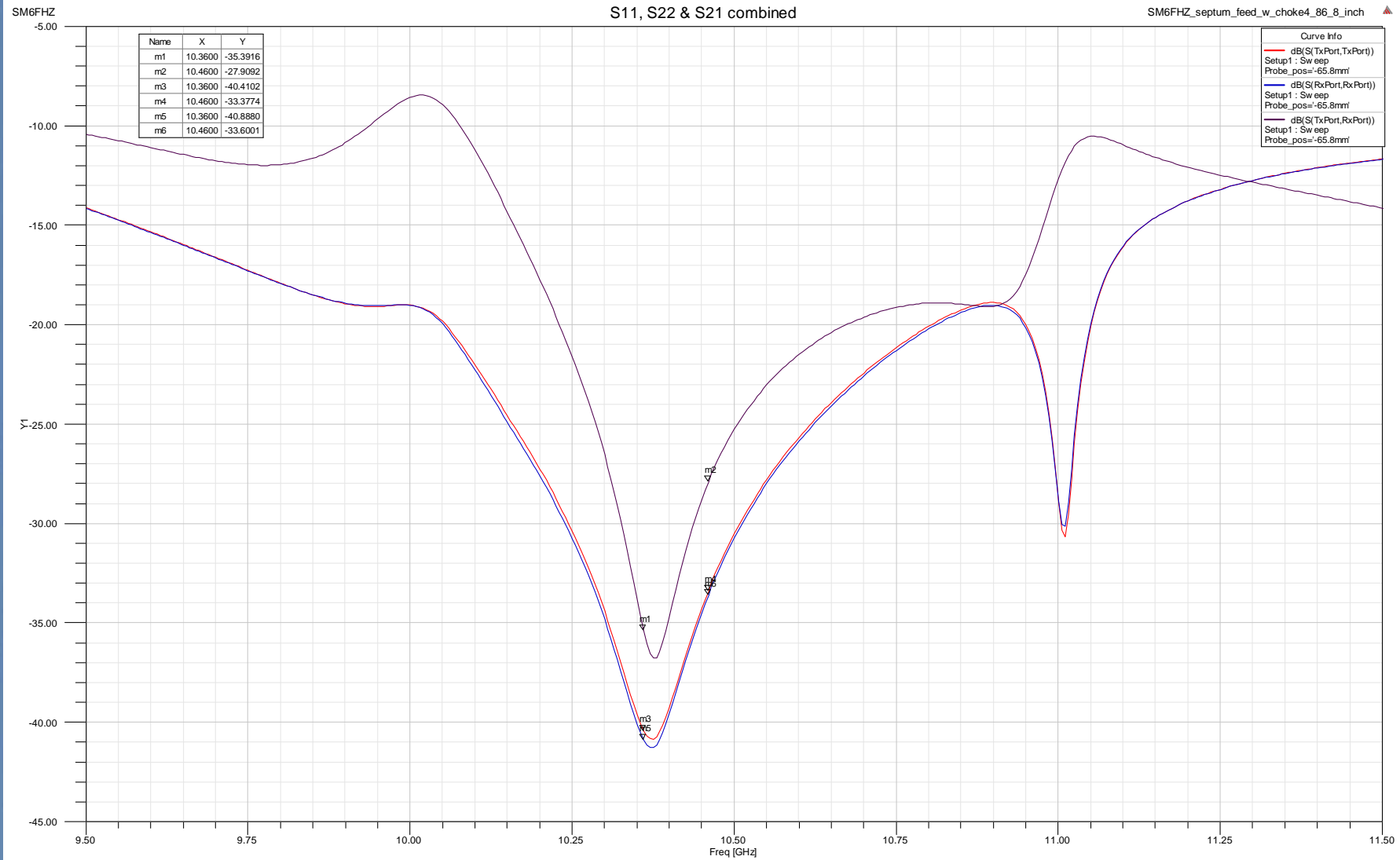

3D Total Power Far Field pattern

(3 cm 0.760 wl WG inch tube)

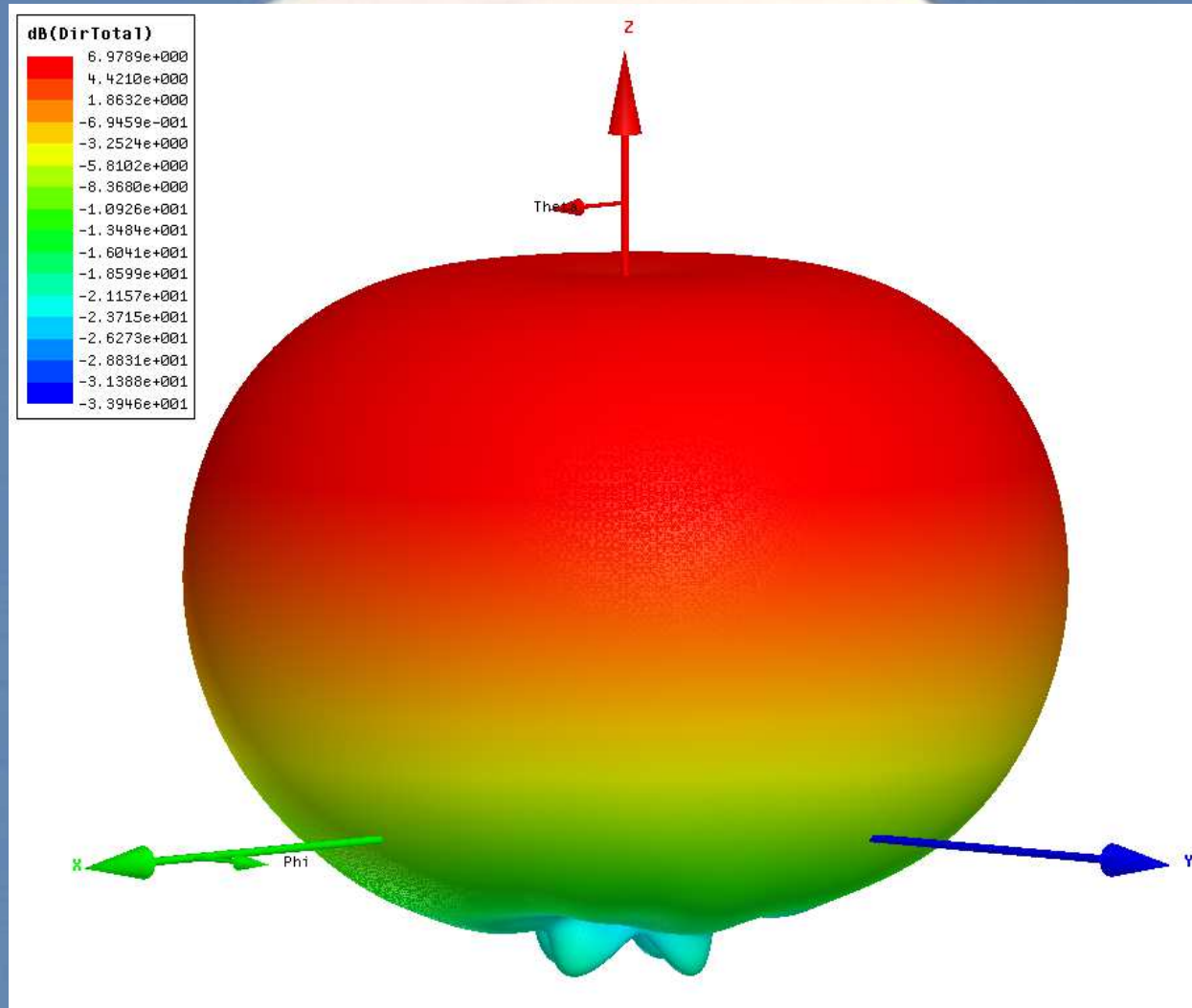

Far Field Pattern 0 deg

(3 cm 0.760 wl WG inch tube)

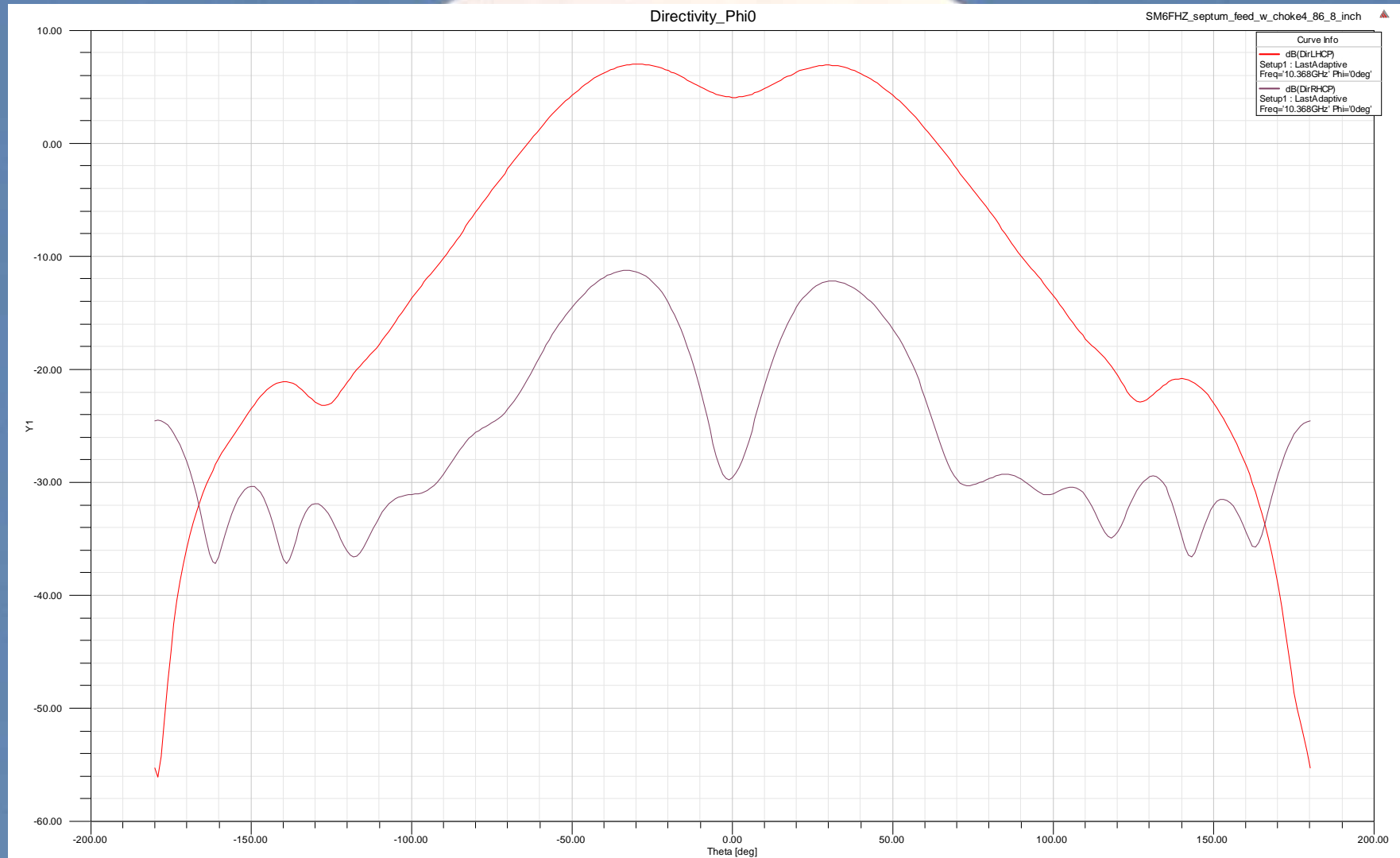

Far Field Phase error

(3 cm 0.760 wl WG inch tube)

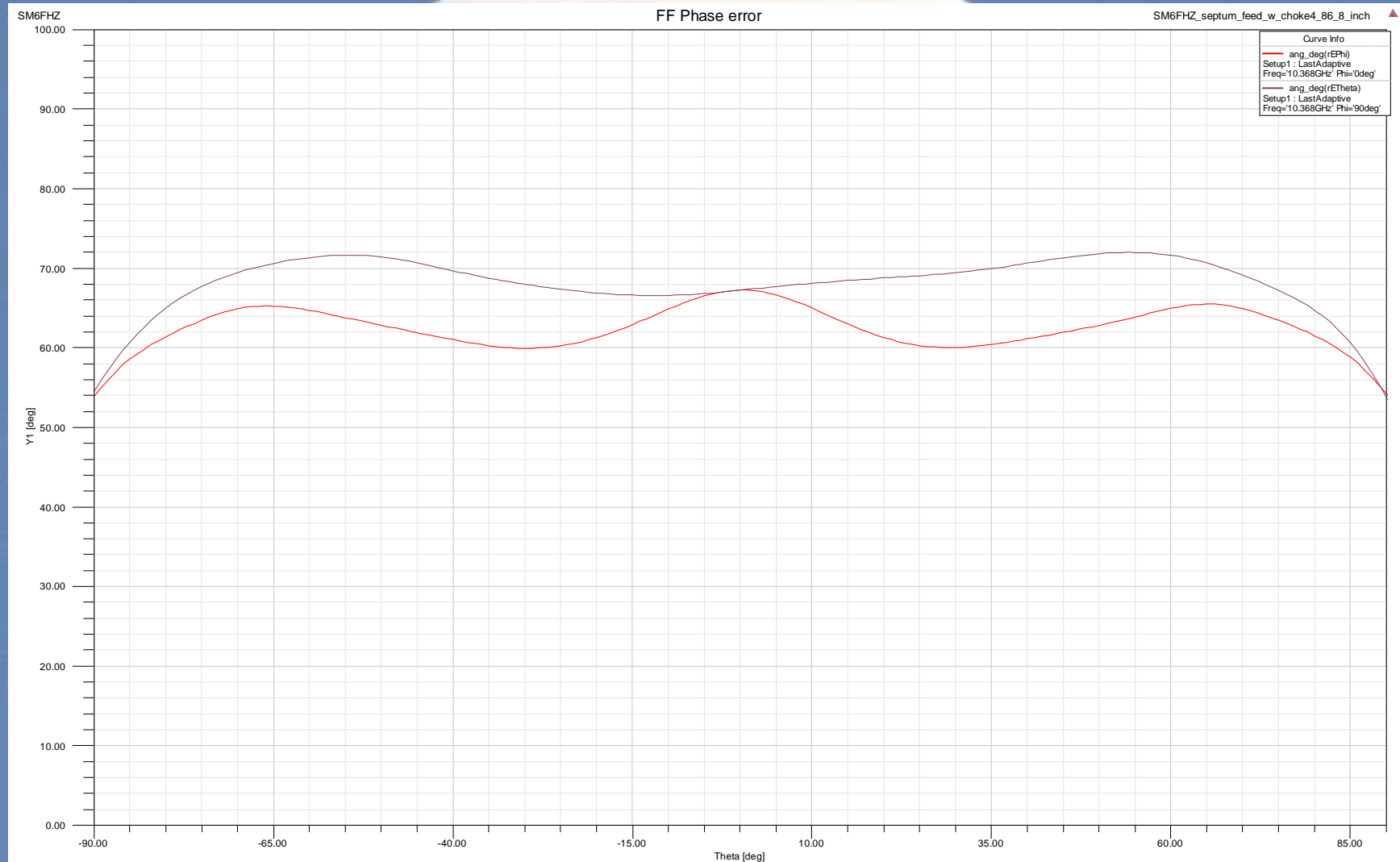

Cross Polar Ratio (3 cm 0.760 wl WG inch tube)

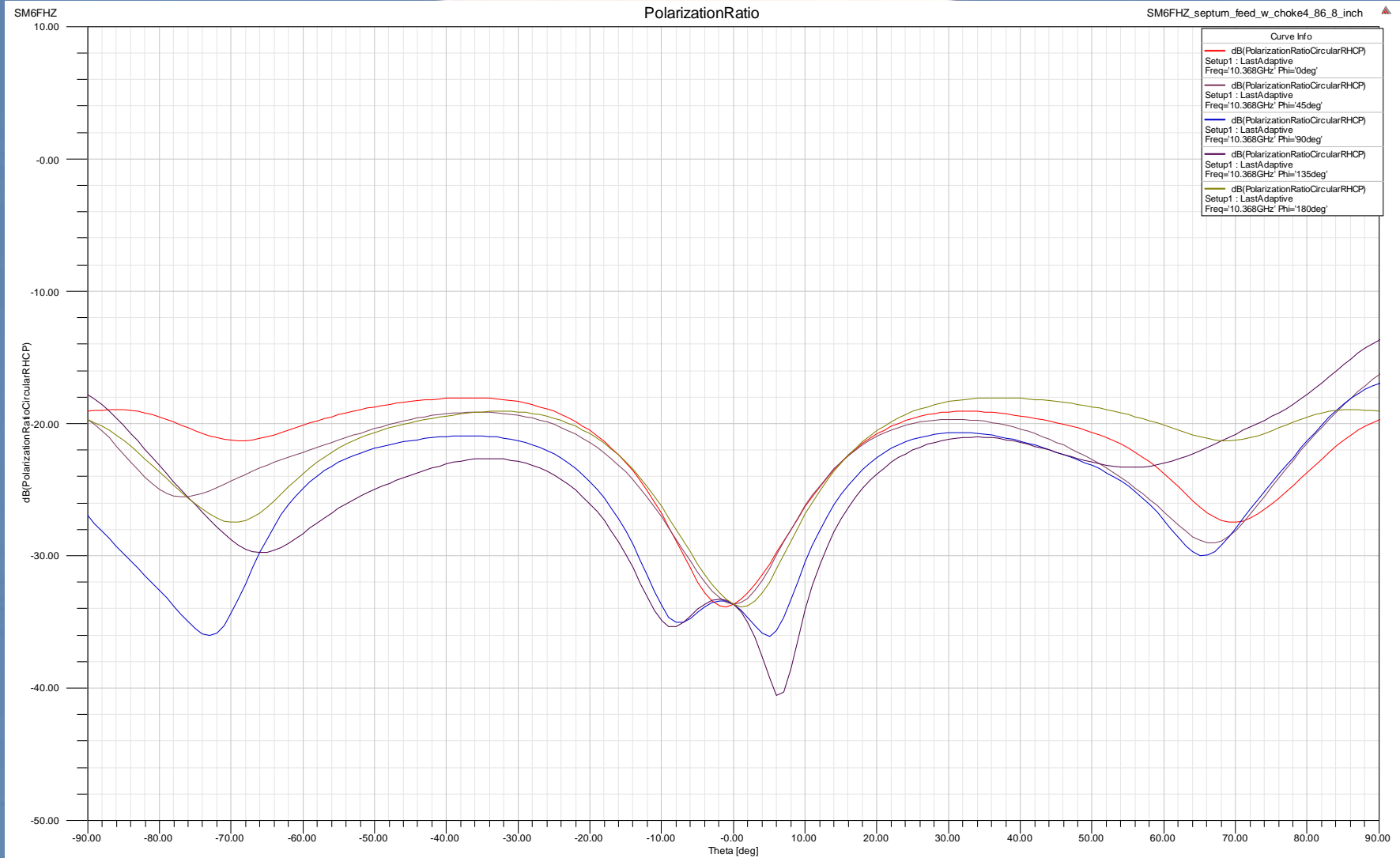

Axial Ratio (3 cm 0.760 wl WG inch tube)

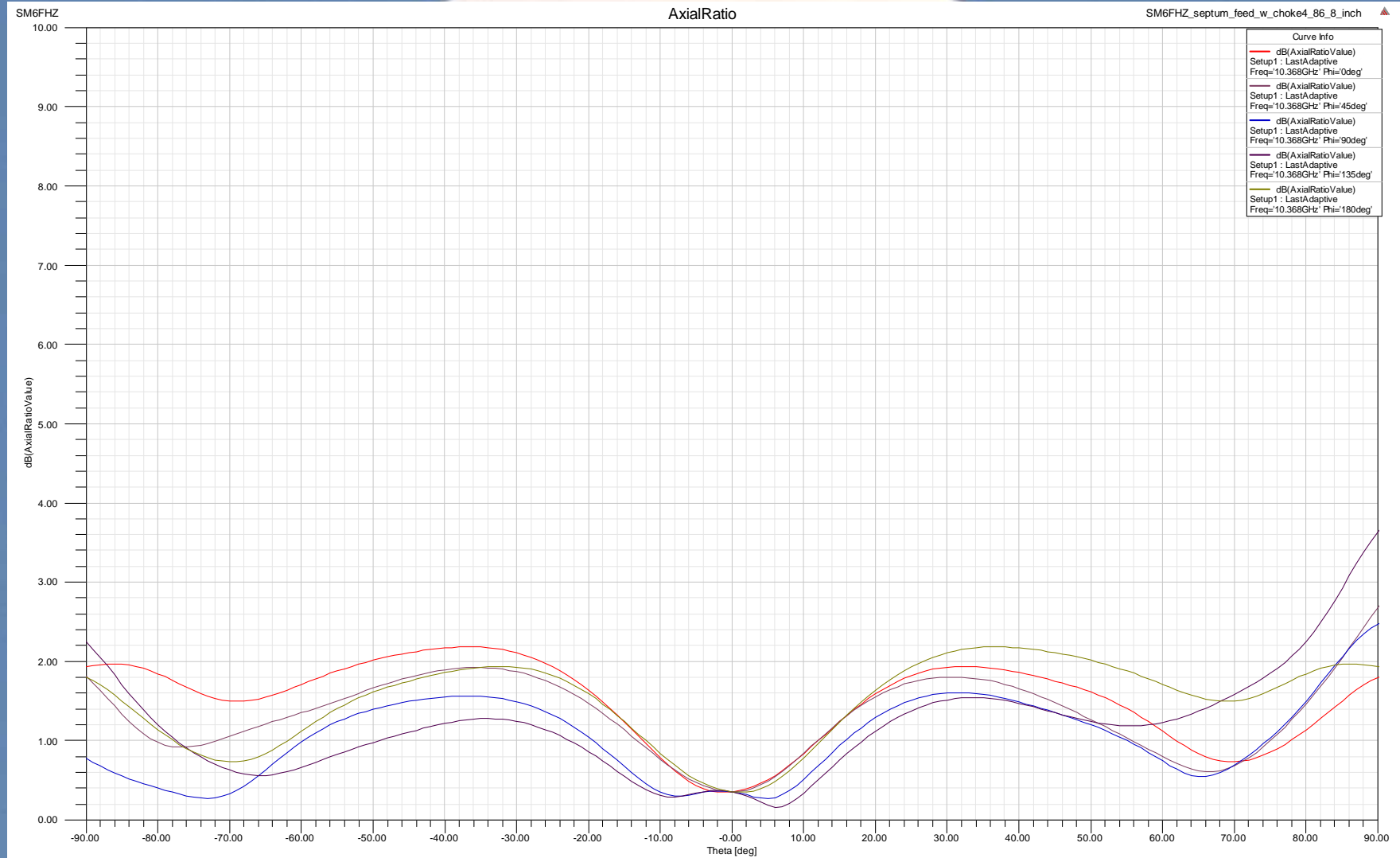



SM6FHZ 3 cm 5 step septum
feed for $f/D \sim 0.5$

0.760 lambda W/G

and a Dual Mode output section

Using standard one inch brass / copper tubing

Solid and transparent models from the simulation (3 cm 0.760 wI WG Dual Mode 39mm inch tube)

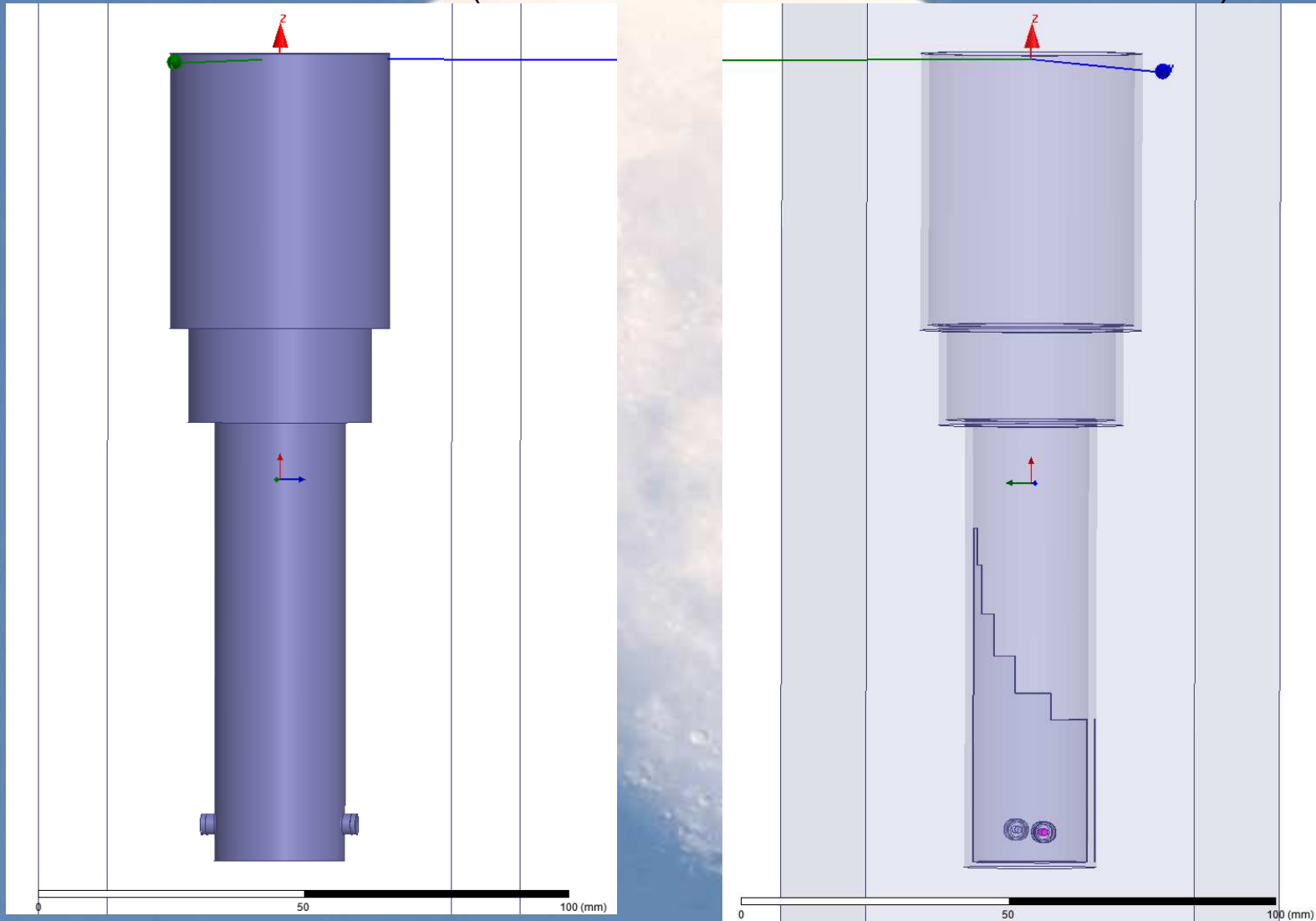

WG and choke dimensions

(3 cm 0.760 wl WG Dual Mode 39mm inch tube)

Circular polarization convention for EME according to Crawford Hill Bulletin No 1:

Tx RHCP in space
Rx LHCP in space

Take polarization reversal into account when using reflector antennas.

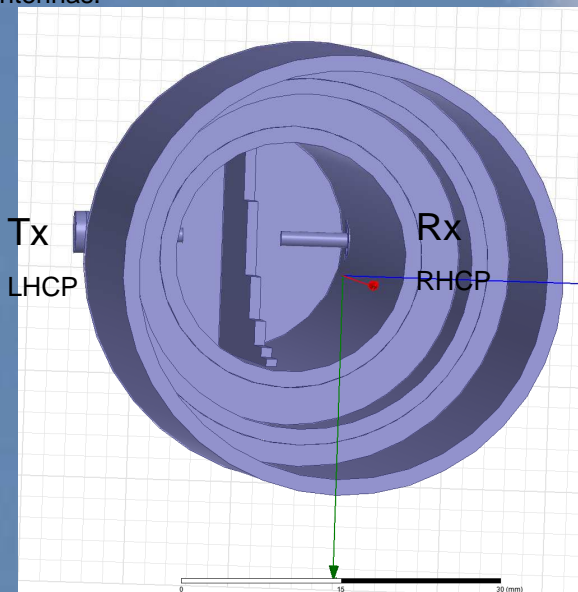

SM6FHZ 2015-05-26
Rev A

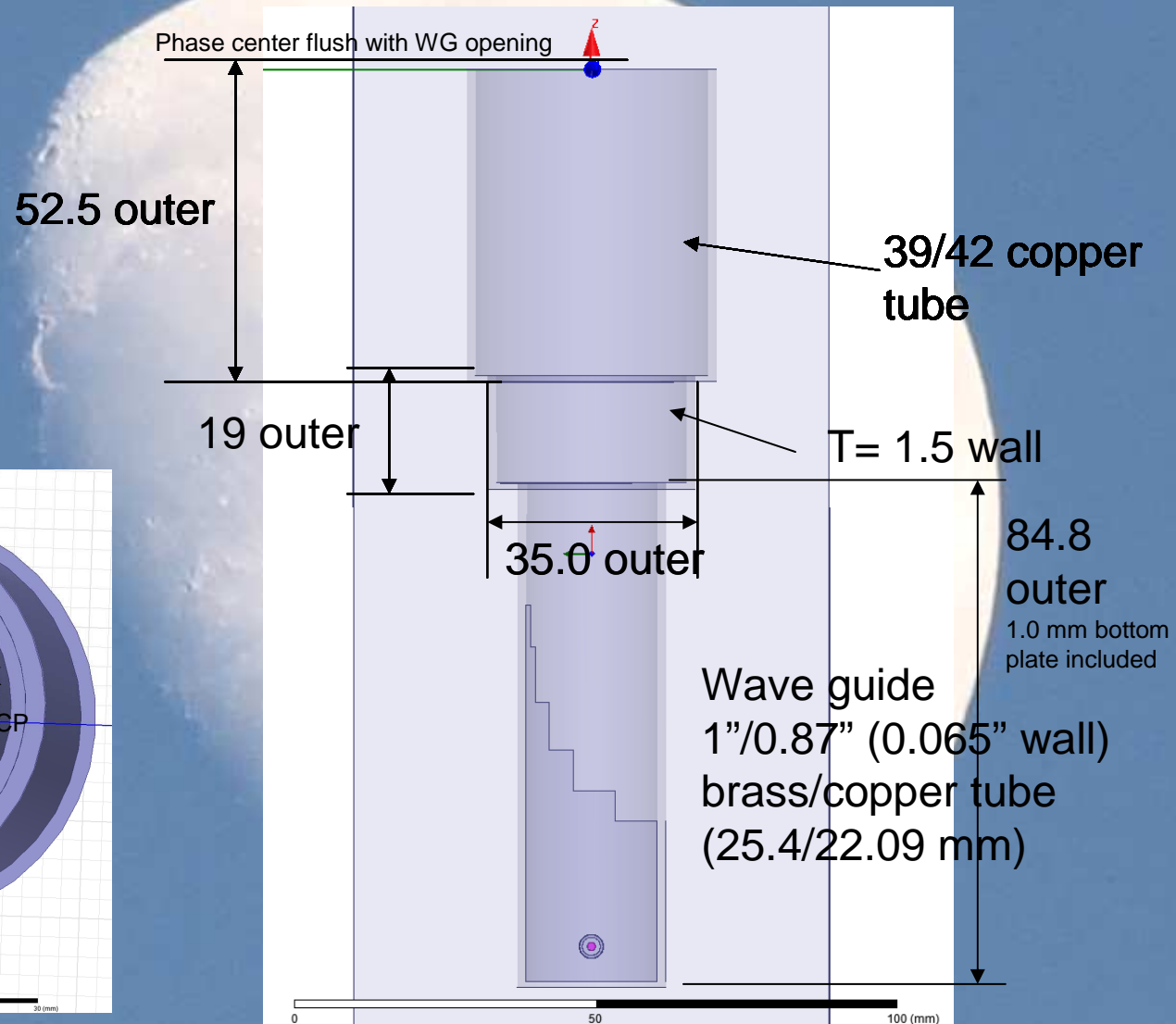

Swedish EME-meeting May 2015

114

Detail of WG / transformer and output section

(3 cm 0.760 wl WG Dual Mode 39mm inch tube)

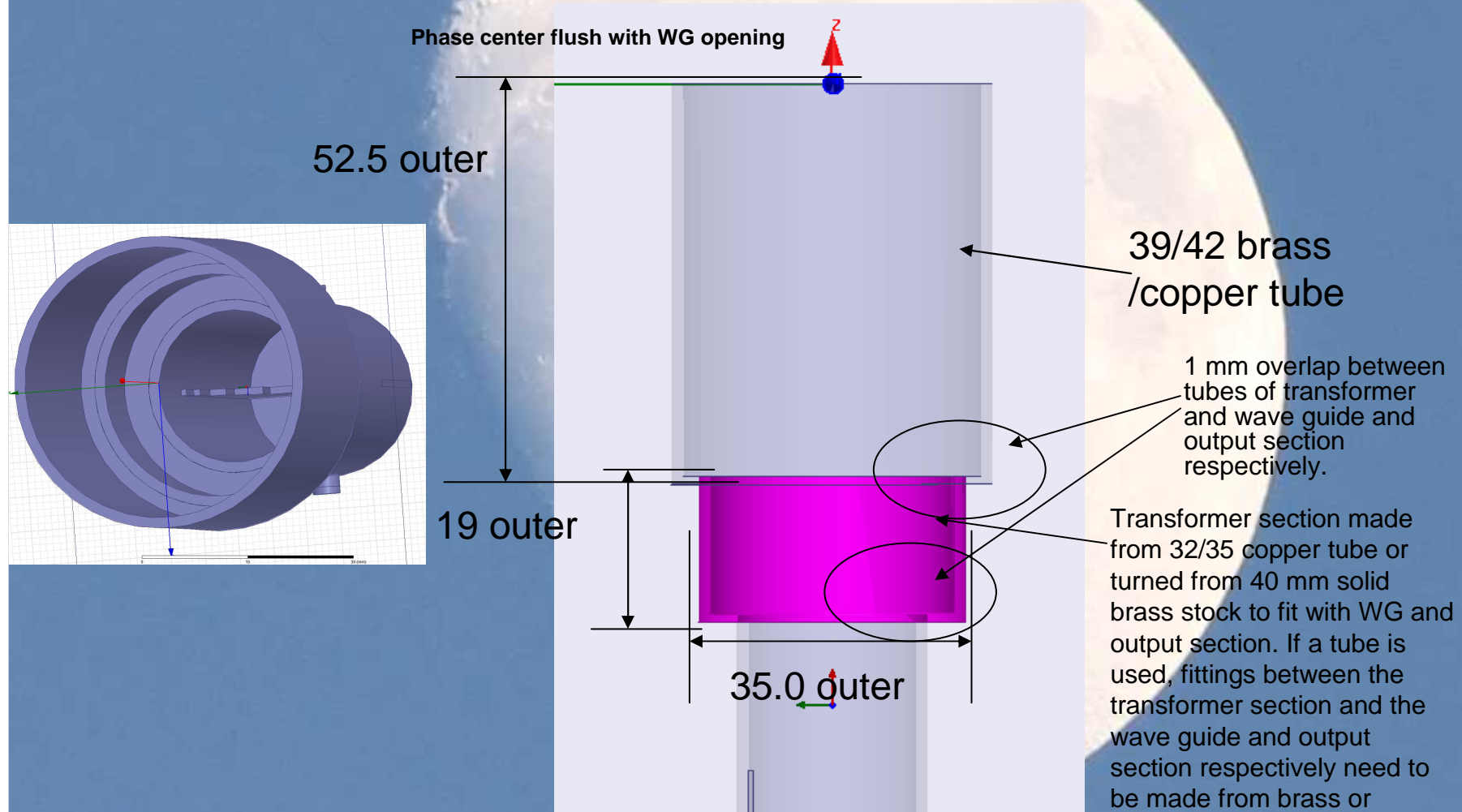

Septum dimensions

(3 cm 0.760 wl WG Dual Mode 39mm inch tube)

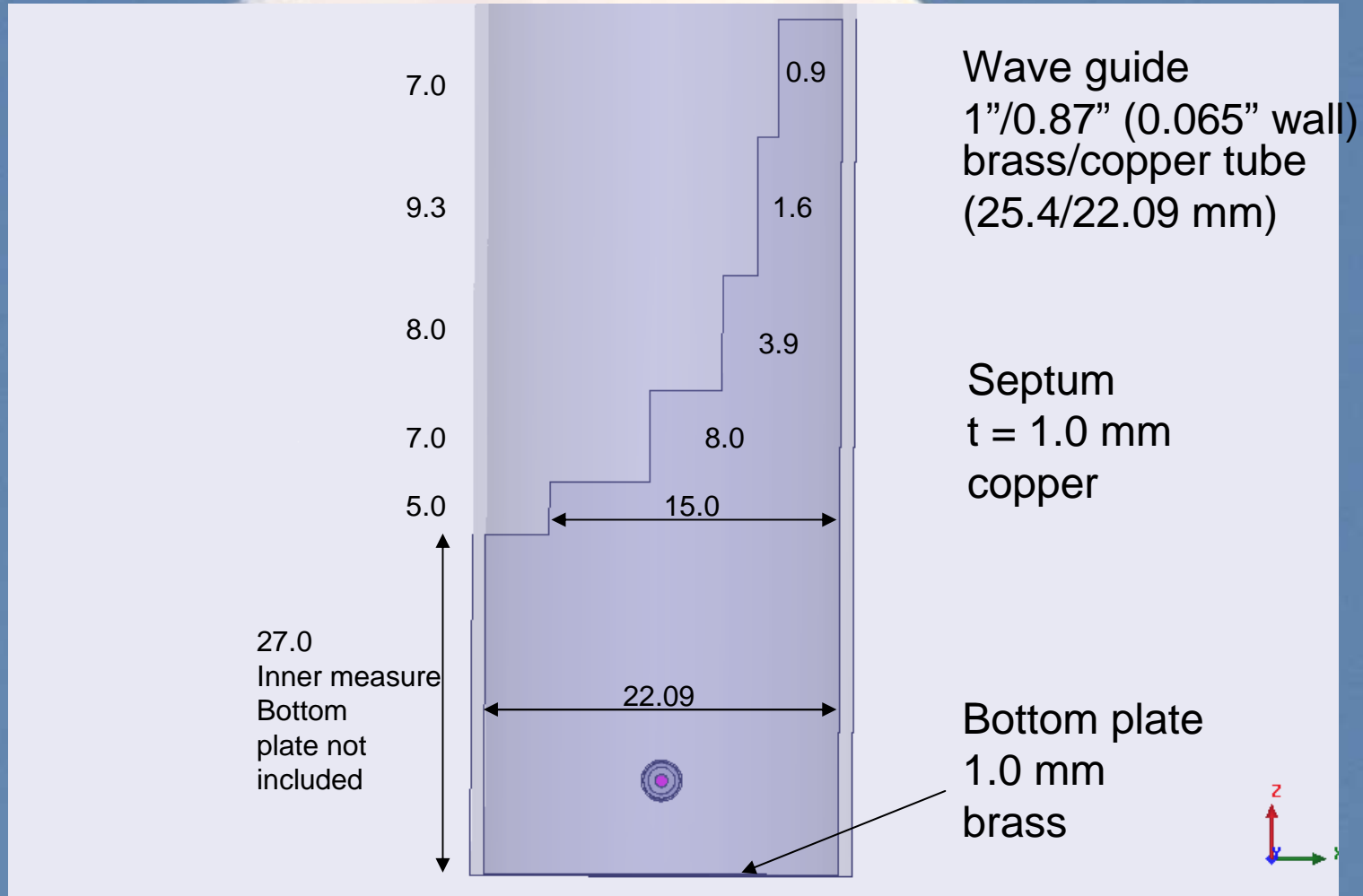

Probe dimensions

(3 cm 0.760 wl WG Dual Mode 39mm inch tube)

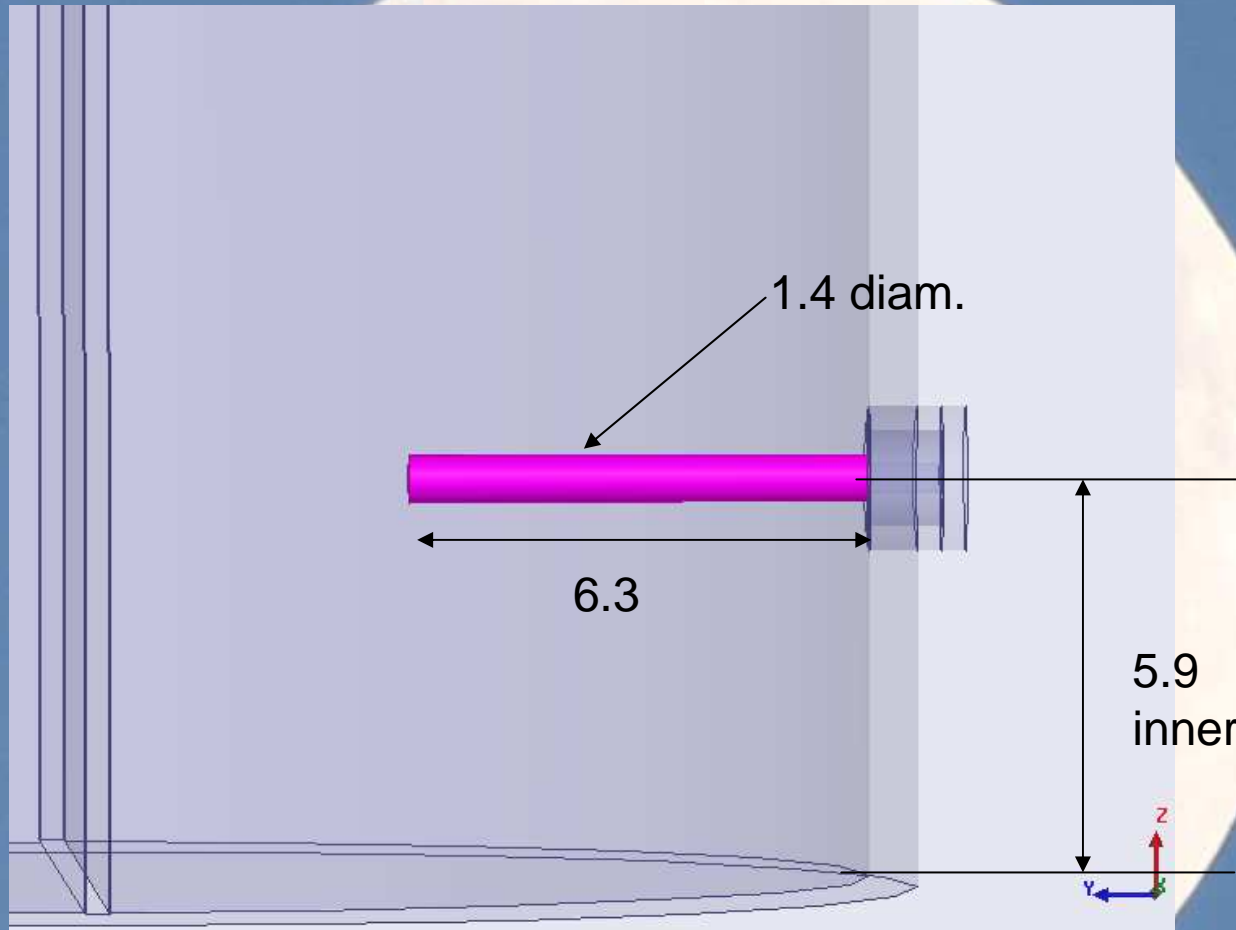

InDish performance inch tube

SM6FHZ 3 cm Dual Mode Feed

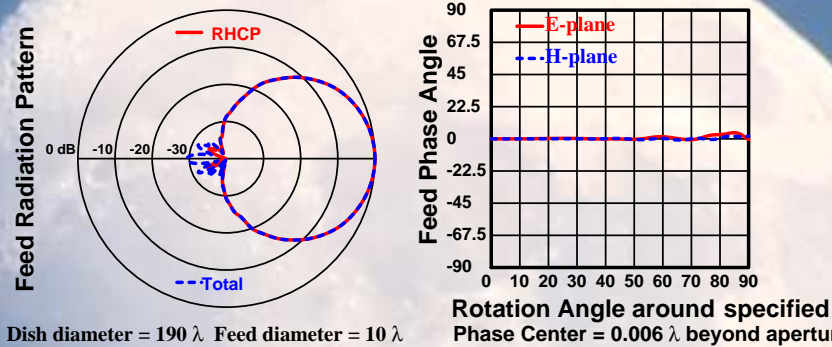

Dish diameter = 190λ Feed diameter = 10λ

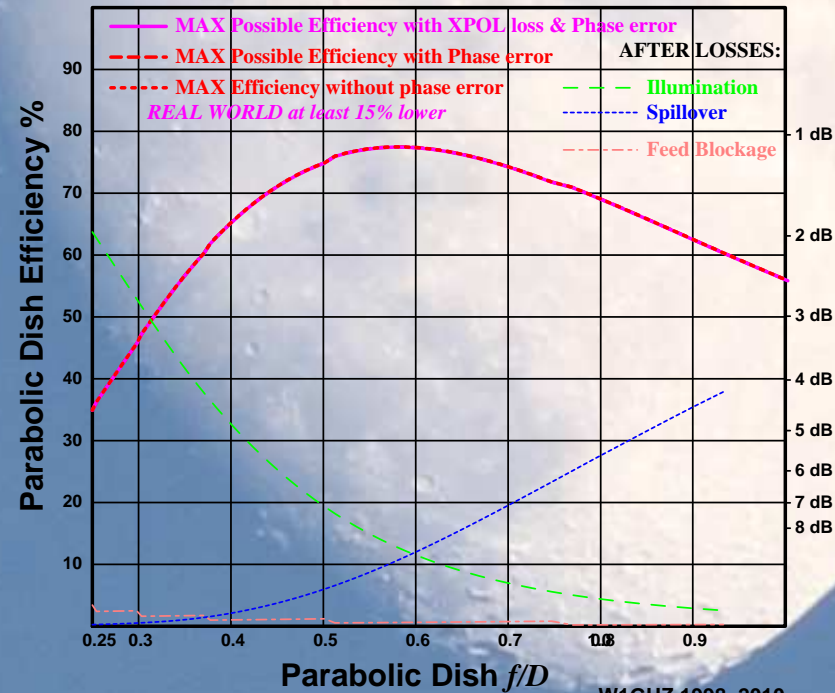

S11, S22, S21 combined

(3 cm 0.760 wl WG Dual Mode 39mm inch tube)

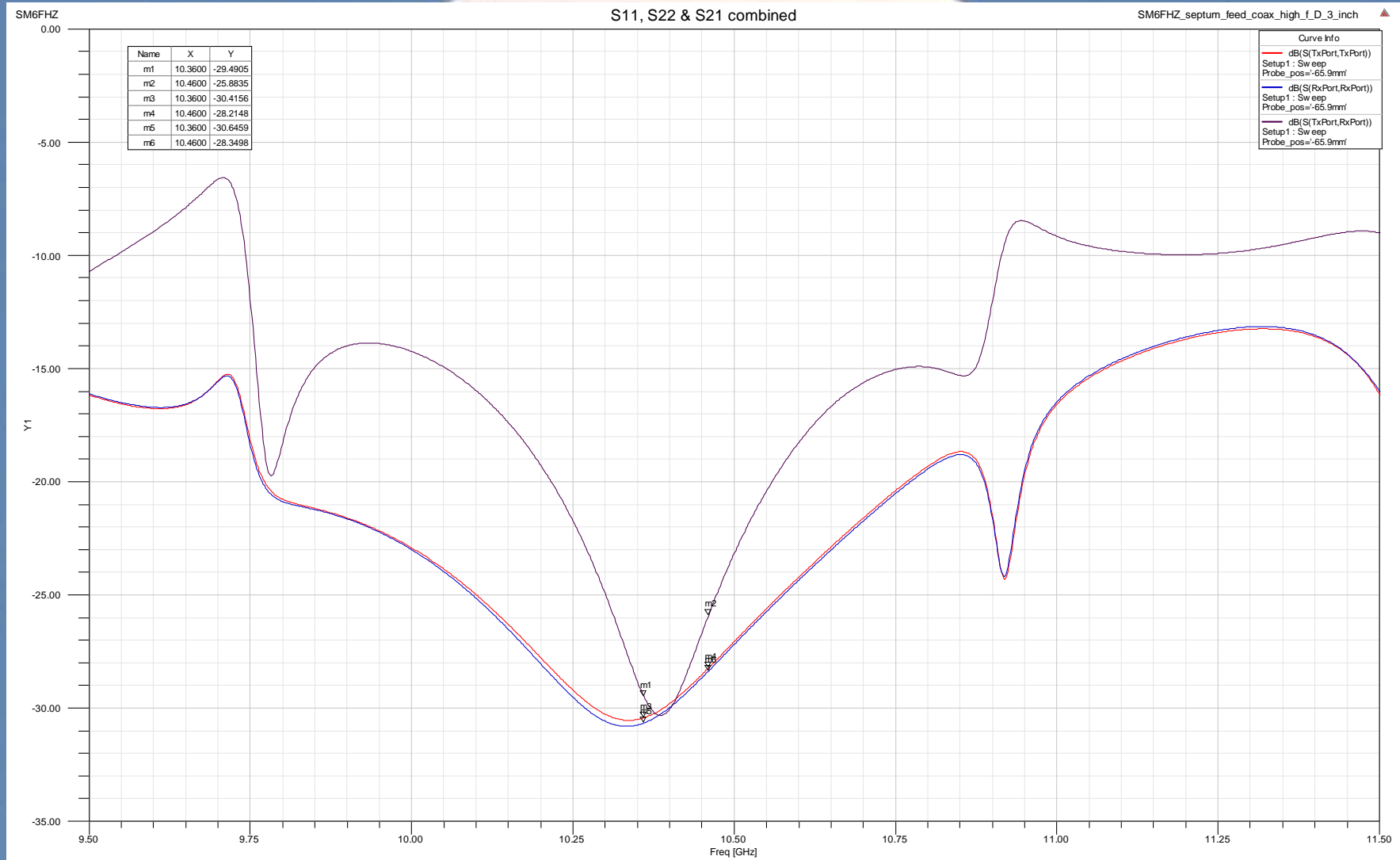

3D Total Power Far Field pattern

(3 cm 0.760 wl WG Dual Mode 39mm inch tube)

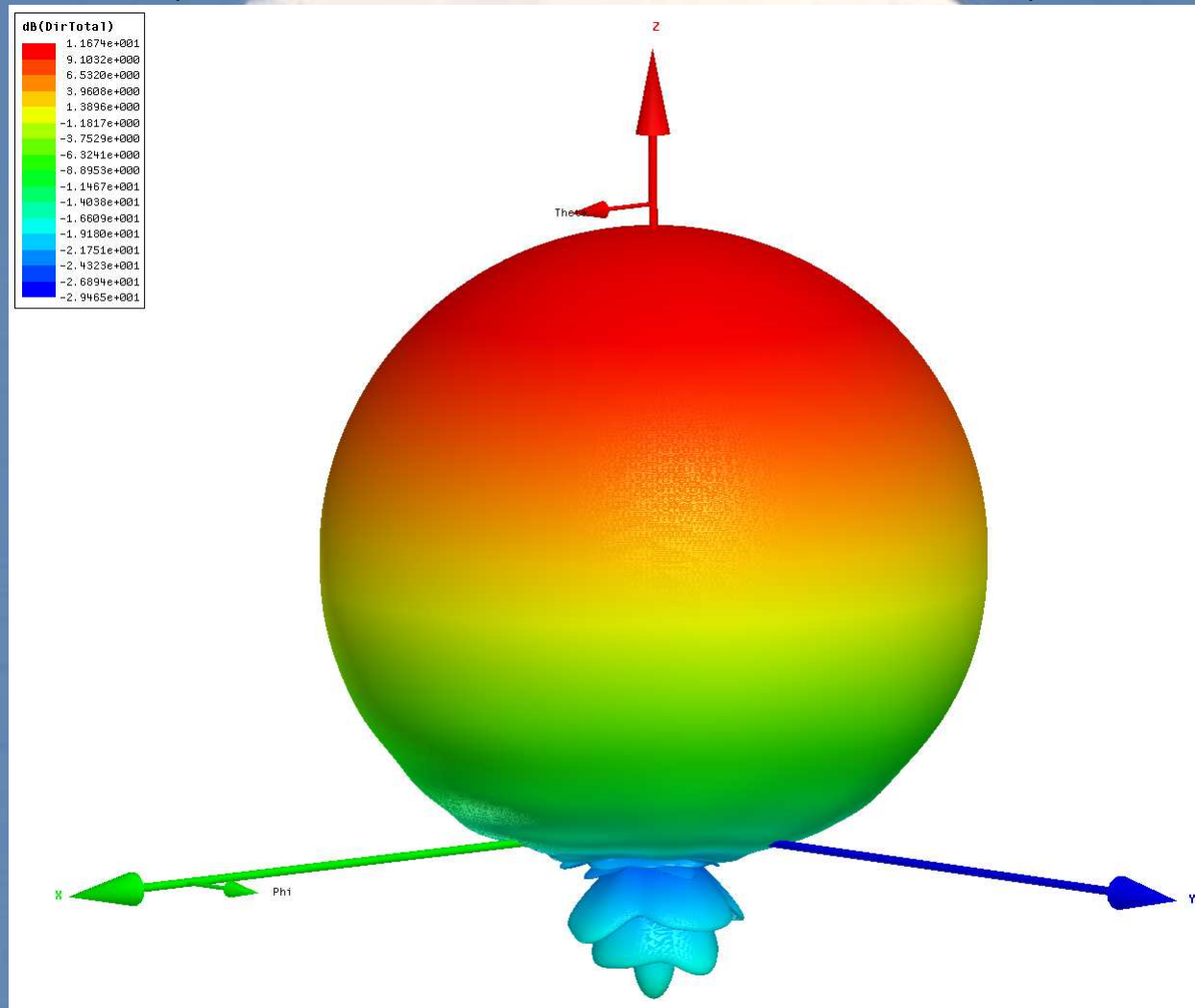

Far Field Pattern 0 deg

(3 cm 0.760 wl WG Dual Mode 39mm inch tube)

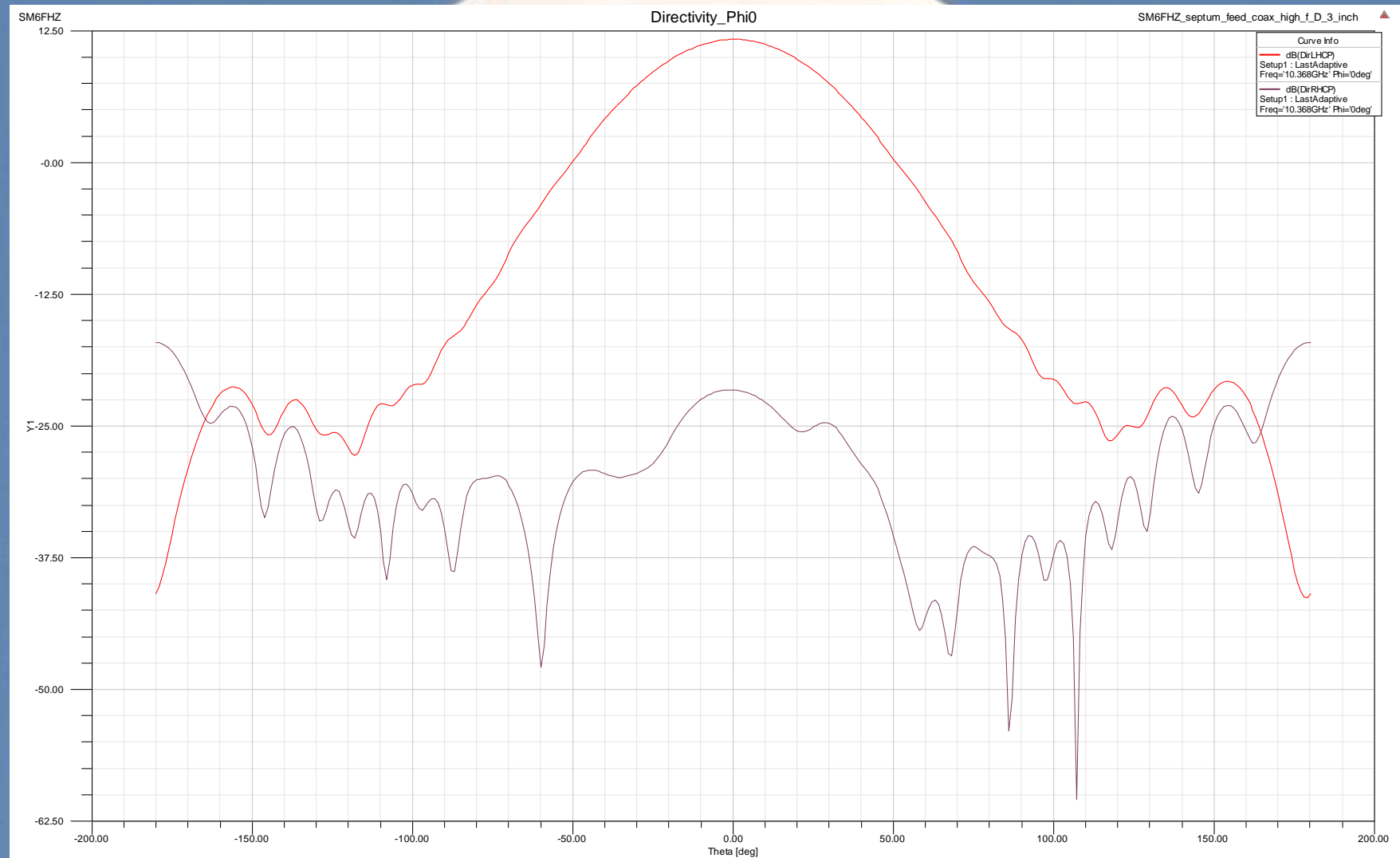

Far Field Phase error

(3 cm 0.760 wl WG Dual Mode 39mm inch tube)

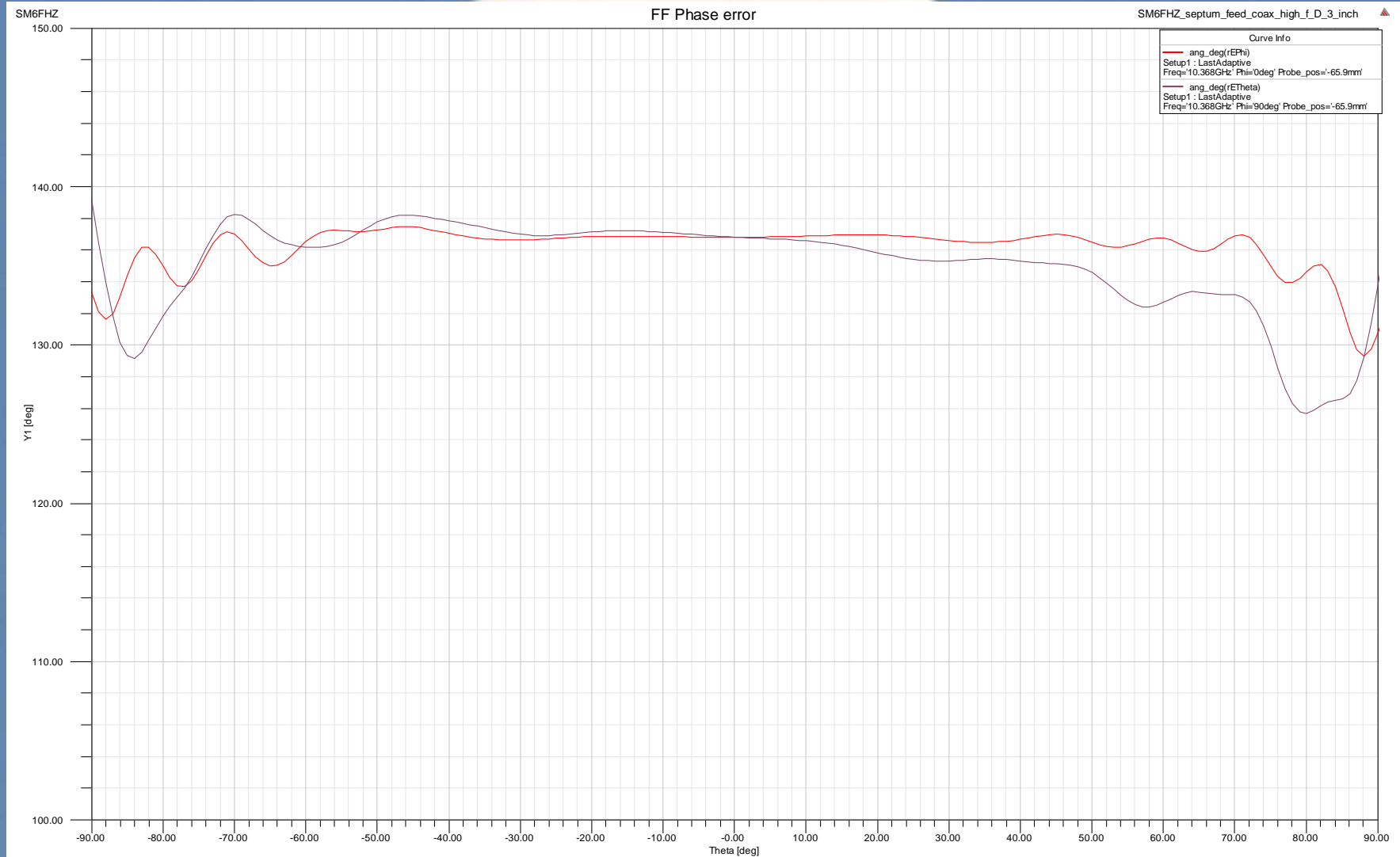

Cross Polar Ratio

(3 cm 0.760 wl WG Dual Mode 39mm inch tube)

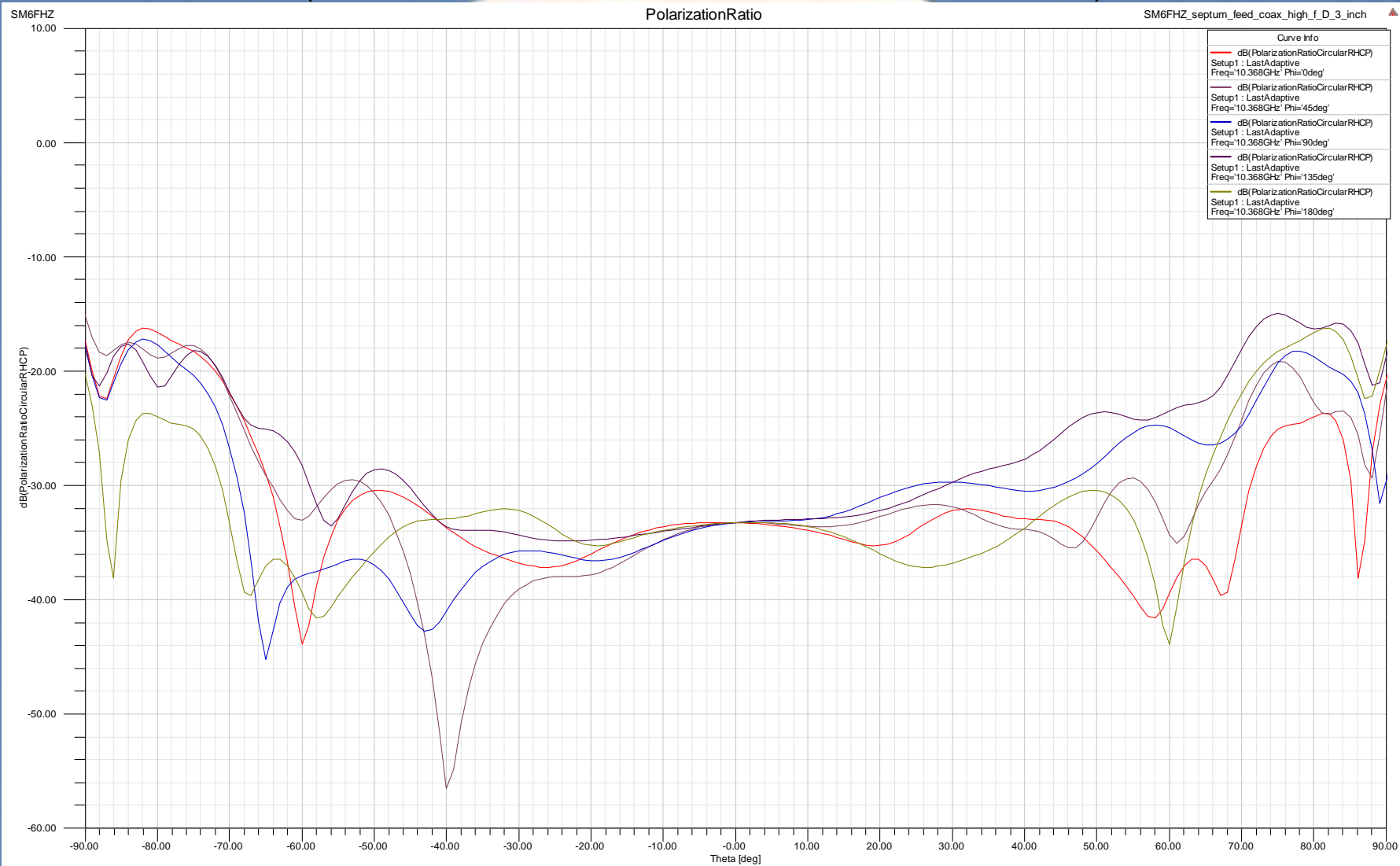

Axial Ratio (3 cm 0.760 w/ WG Dual Mode 39mm inch tube)

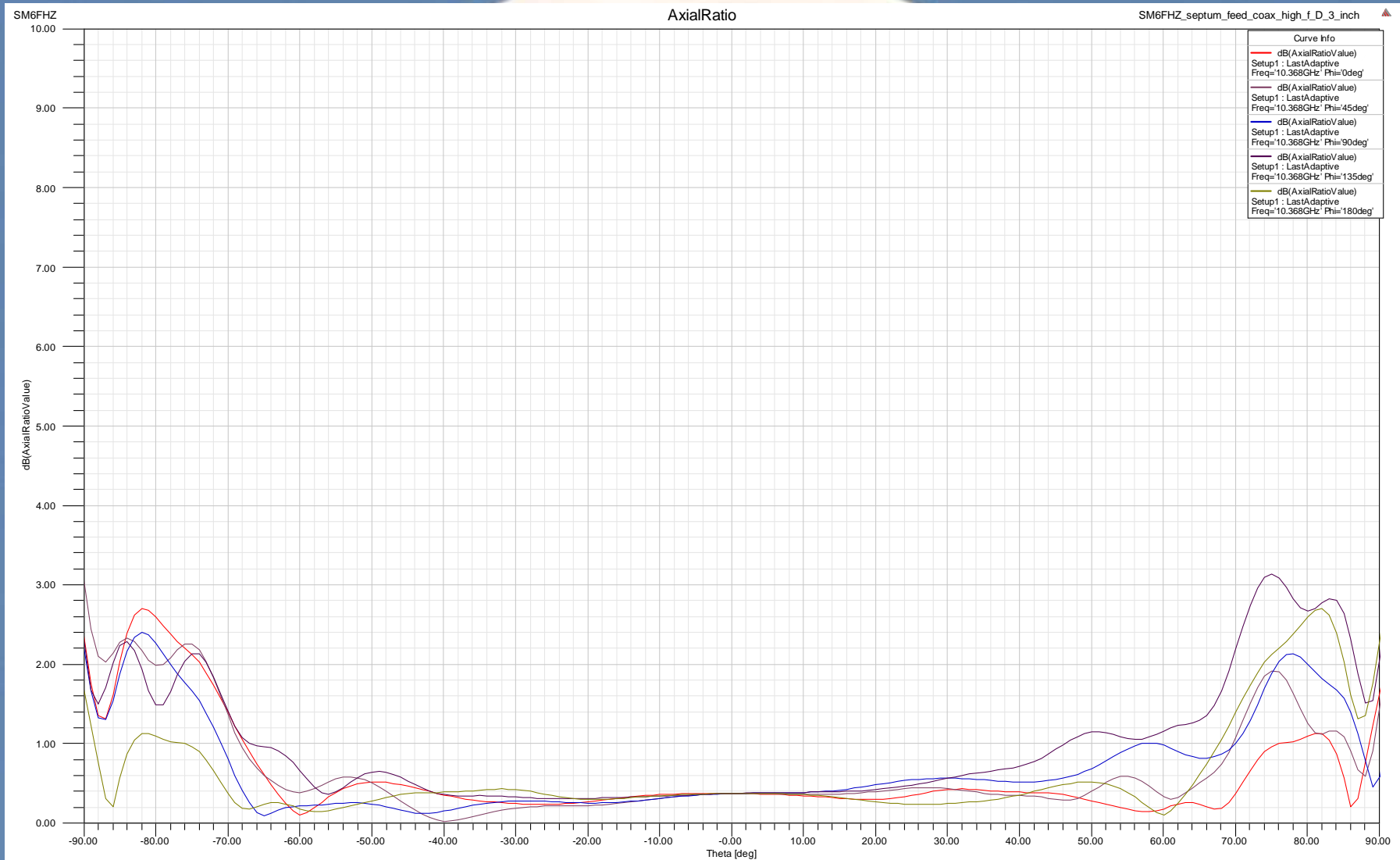

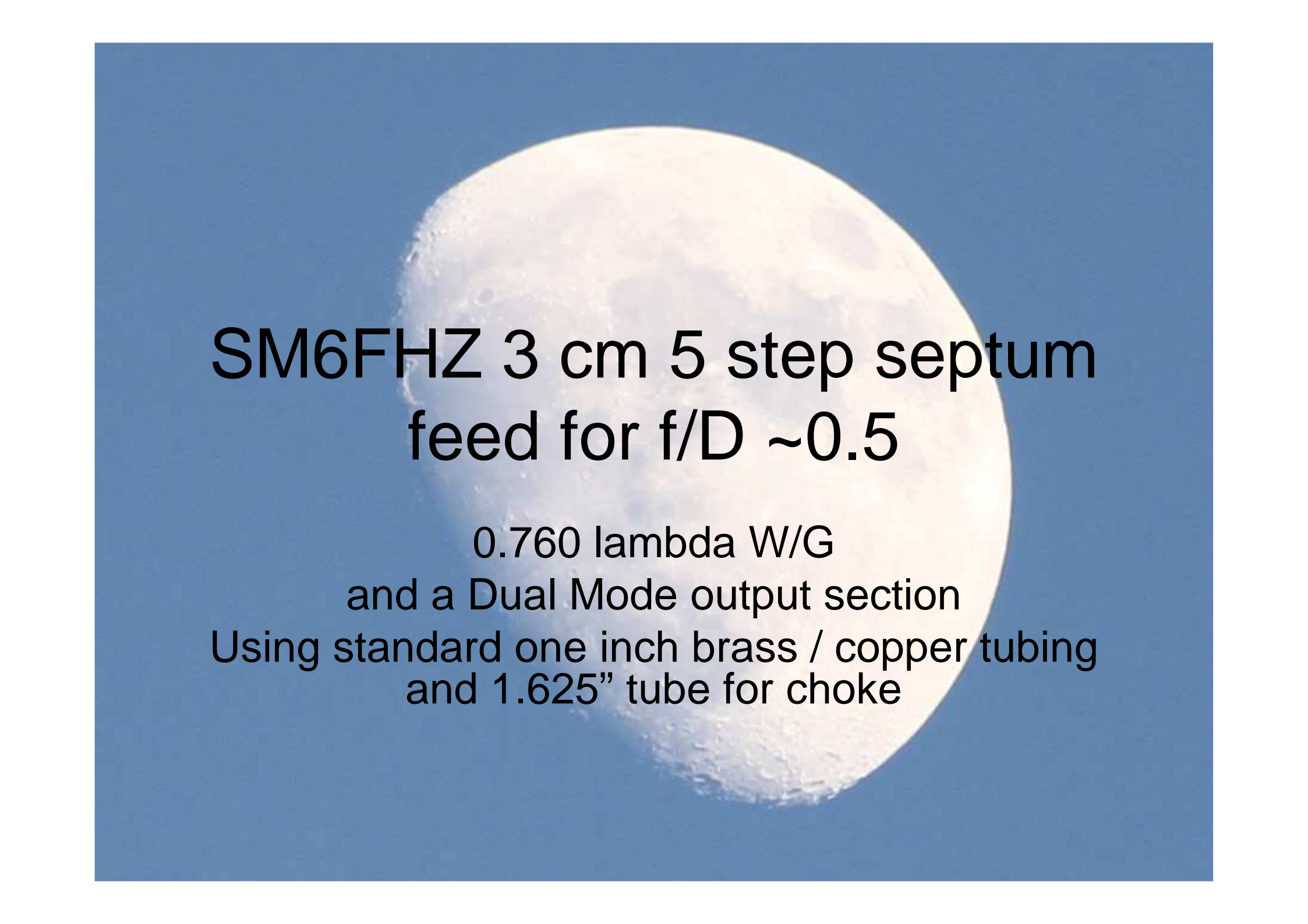

SM6FHZ 3 cm 5 step septum
feed for $f/D \sim 0.5$

0.760 lambda W/G
and a Dual Mode output section
Using standard one inch brass / copper tubing
and 1.625" tube for choke

Solid and transparent models from the simulation (3 cm 0.760 wl WG Dual Mode 39mm inch tubing)

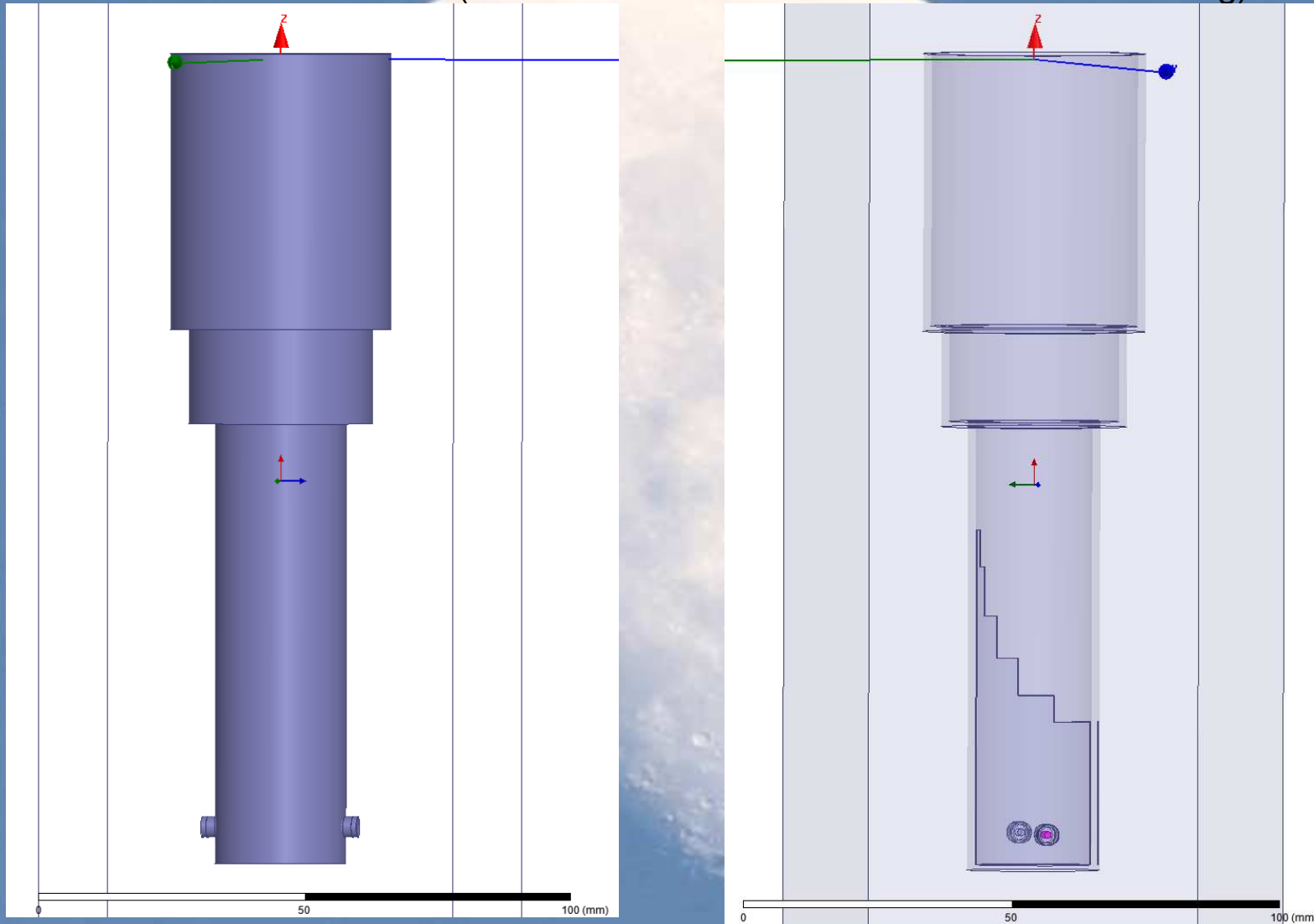

WG and choke dimensions

(3 cm 0.760 wl WG Dual Mode 39mm inch tubing)

Circular polarization convention for EME according to Crawford Hill Bulletin No 1:

Tx RHCP in space
Rx LHCP in space

Take polarization reversal into account when using reflector antennas.

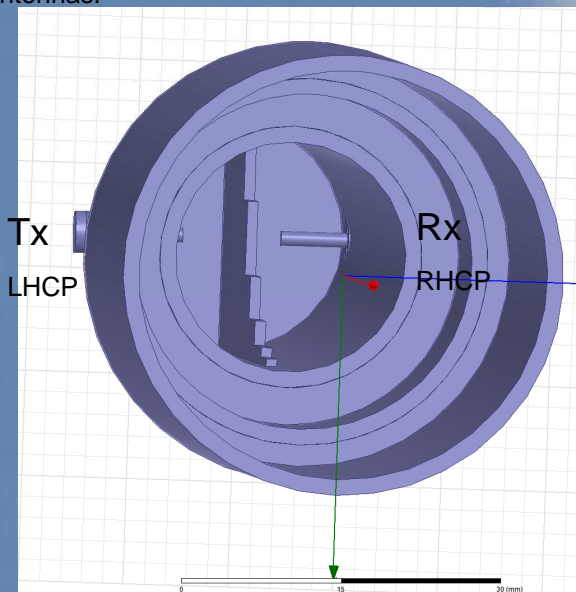

SM6FHZ 2015-05-26
Rev A

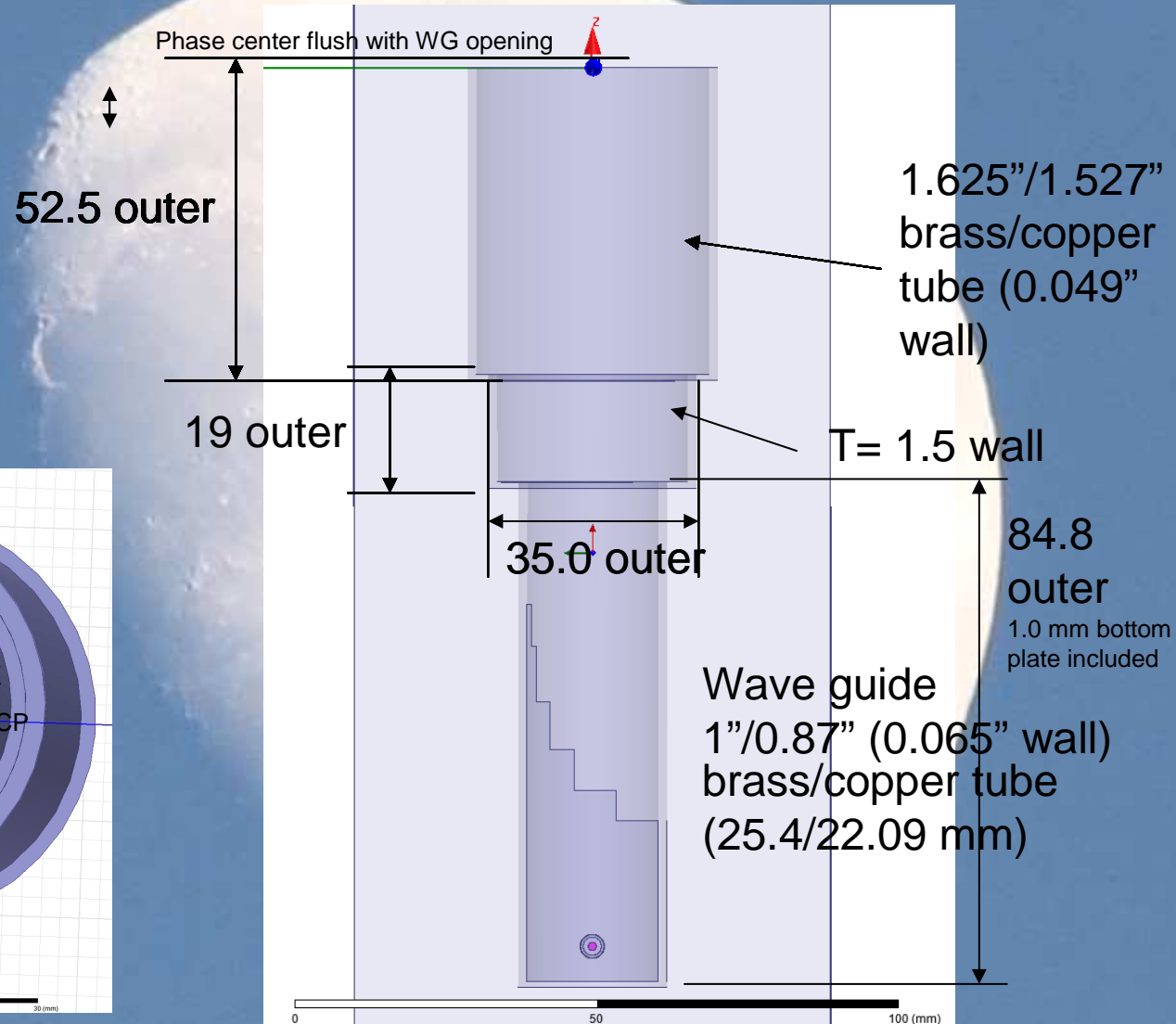

Swedish EME-meeting May 2015

127

Detail of WG / transformer and output section

(3 cm 0.760 wl WG Dual Mode 39mm inch tubing)

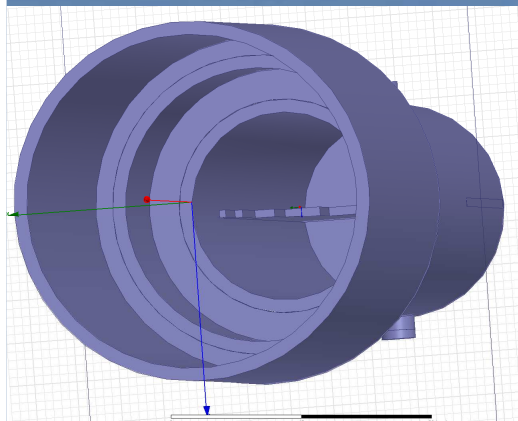
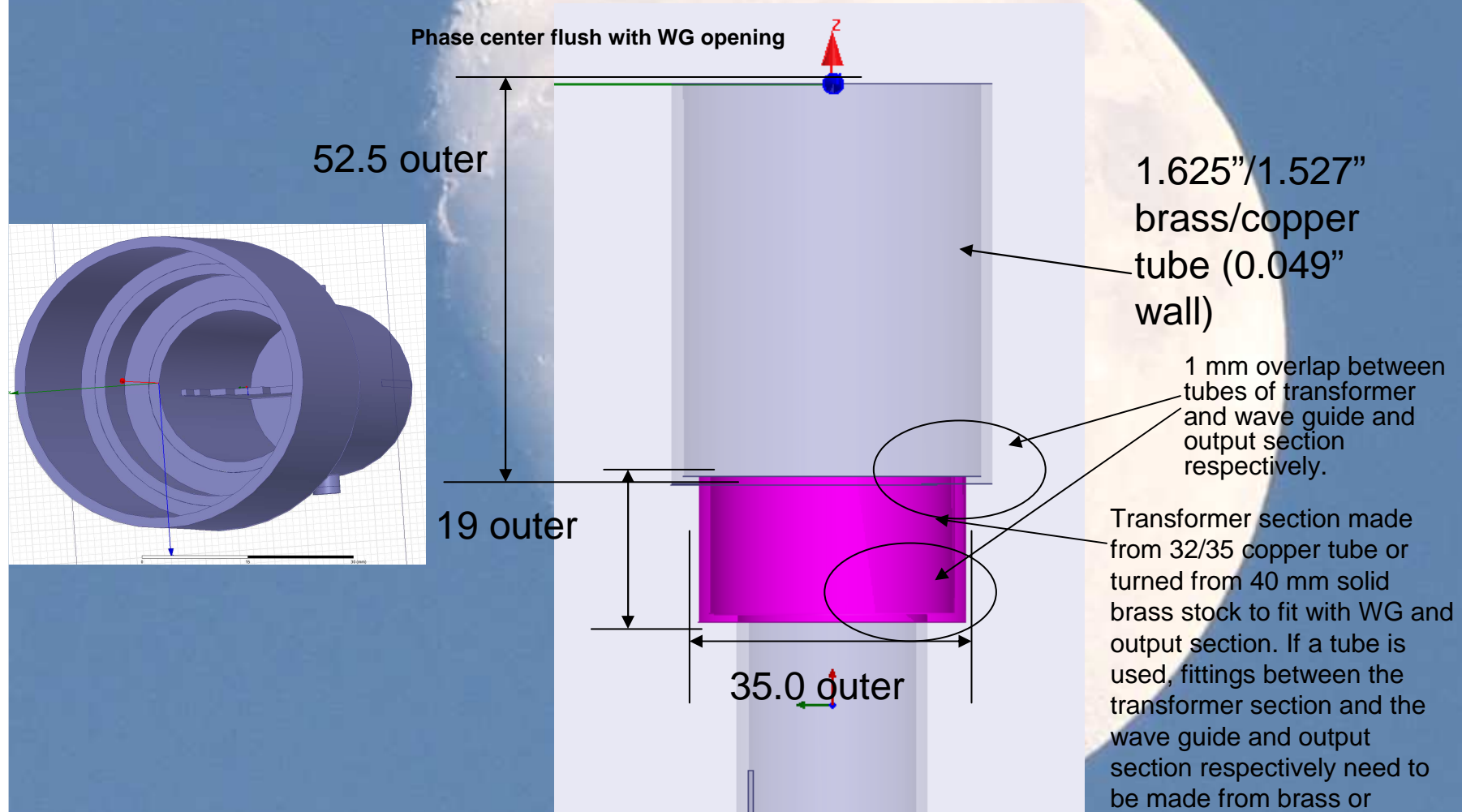

Septum dimensions

(3 cm 0.760 wl WG Dual Mode 39mm inch tubing)

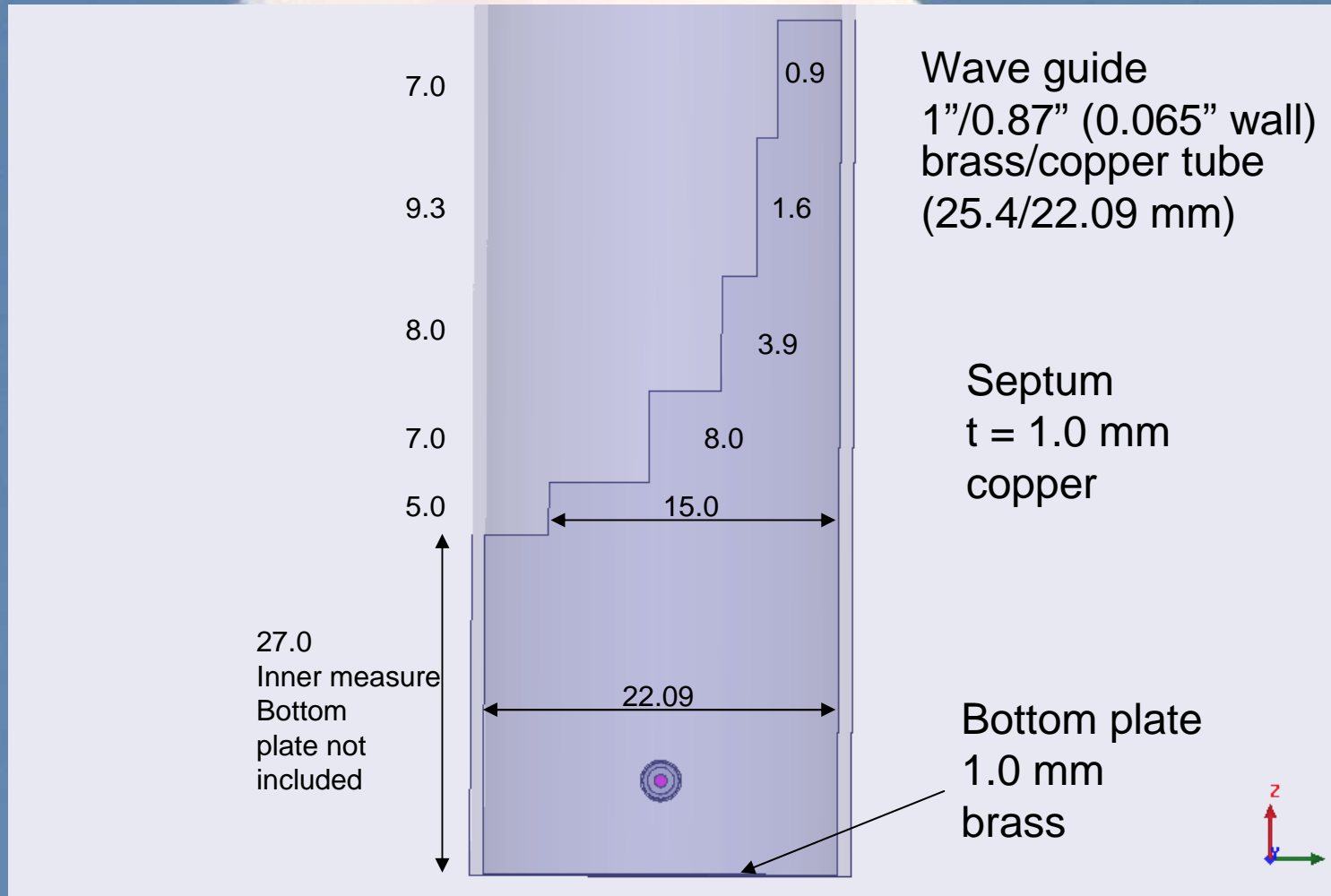

Probe dimensions

(3 cm 0.760 wI WG Dual Mode 39mm inch tubing)

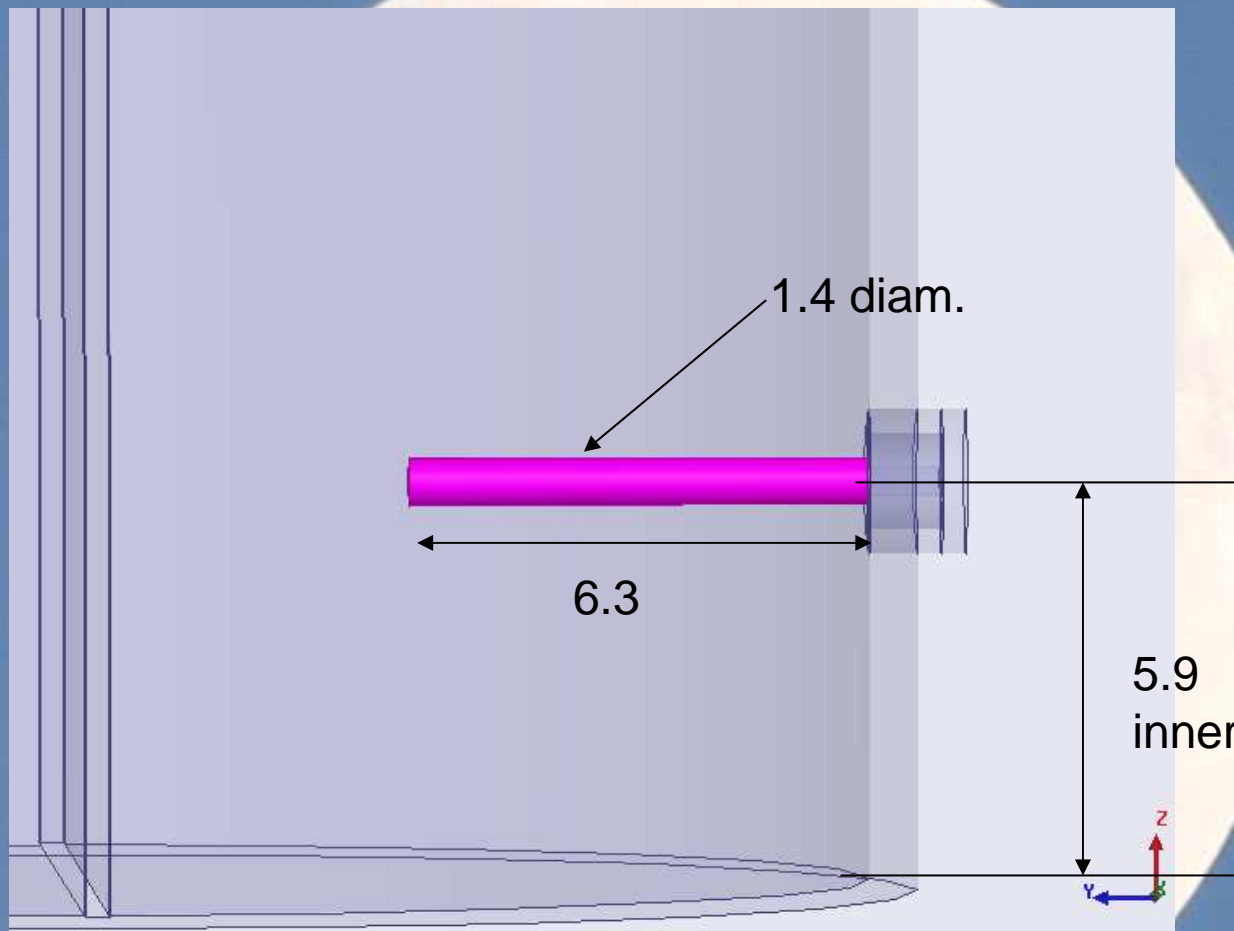

InDish performance inch tubing

SM6FHZ 3 cm Dual Mode Feed

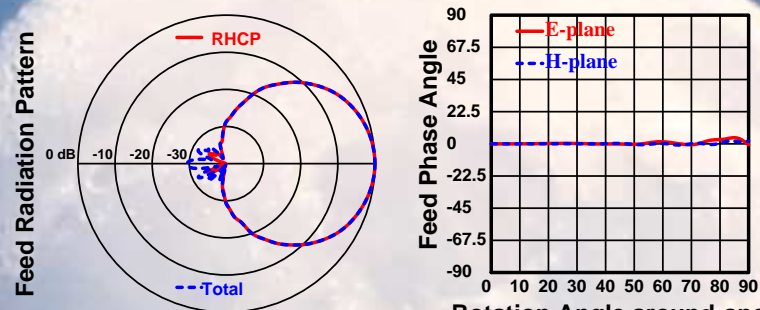

Dish diameter = 190λ Feed diameter = 10λ

Rotation Angle around specified Phase Center = 0.006λ beyond aperture

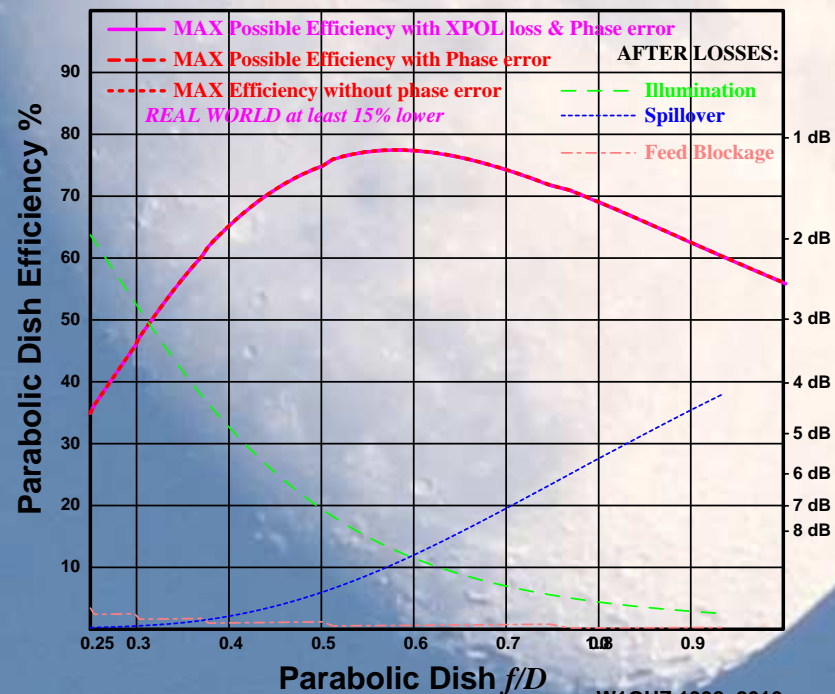

W1GHZ 1998, 2010

S11, S22, S21 combined

(3 cm 0.760 wl WG Dual Mode 39mm inch tubing)

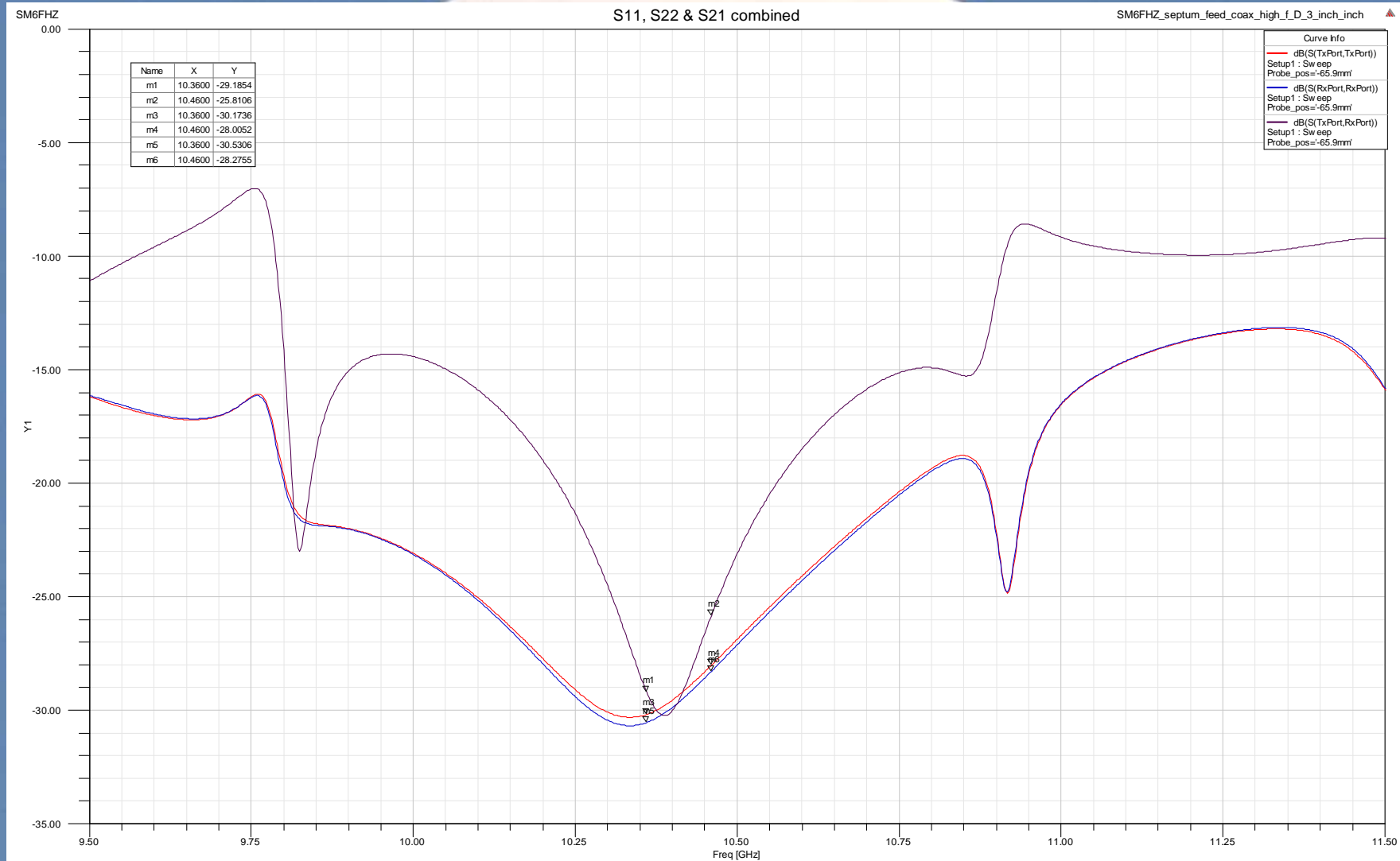

3D Total Power Far Field pattern

(3 cm 0.760 wl WG Dual Mode 39mm inch tubing)

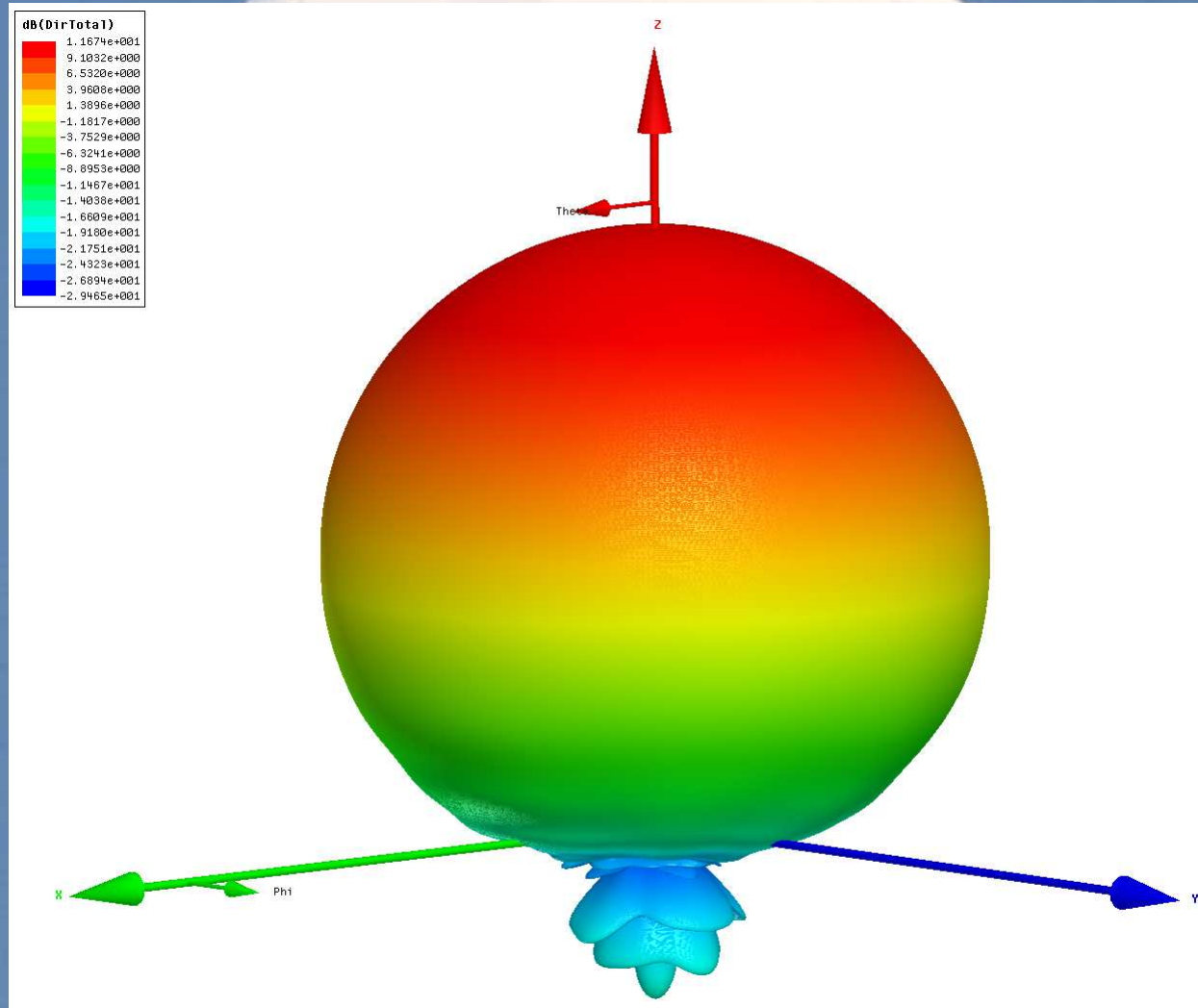

Far Field Pattern 0 deg

(3 cm 0.760 wl WG Dual Mode 39mm inch tubing)

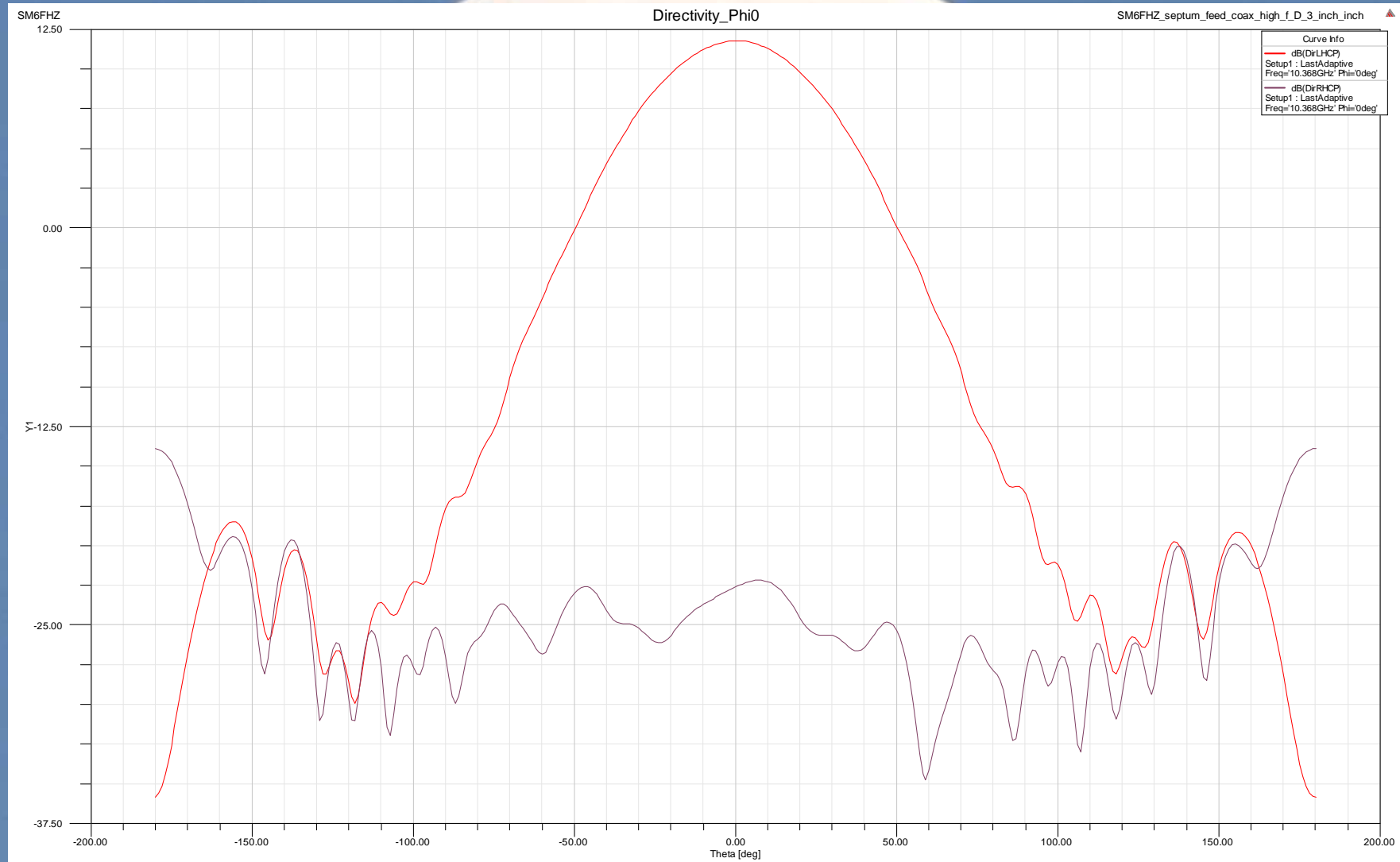

Far Field Phase error

(3 cm 0.760 wl WG Dual Mode 39mm inch tubing)

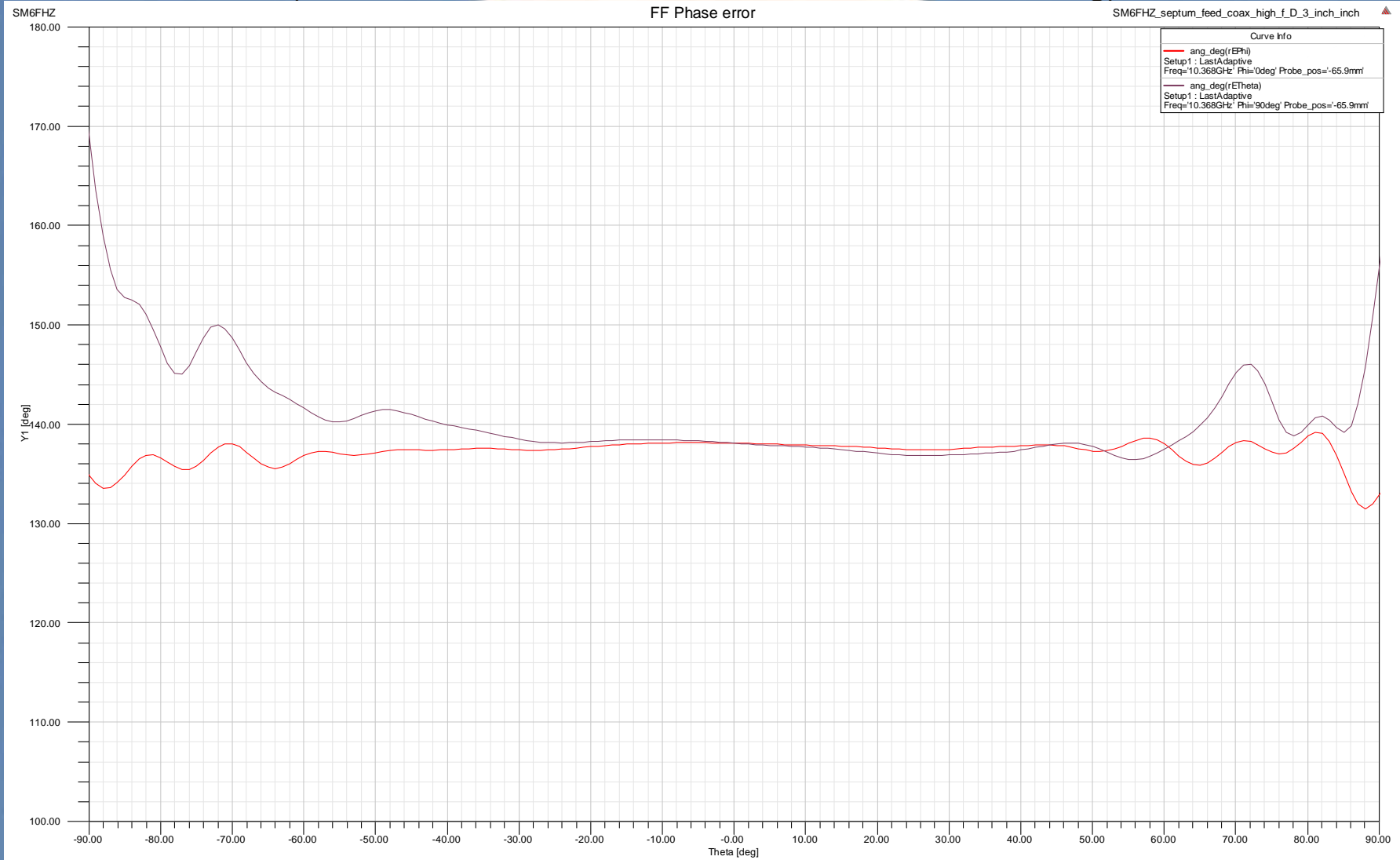

Cross Polar Ratio

(3 cm 0.760 wl WG Dual Mode 39mm inch tubing)

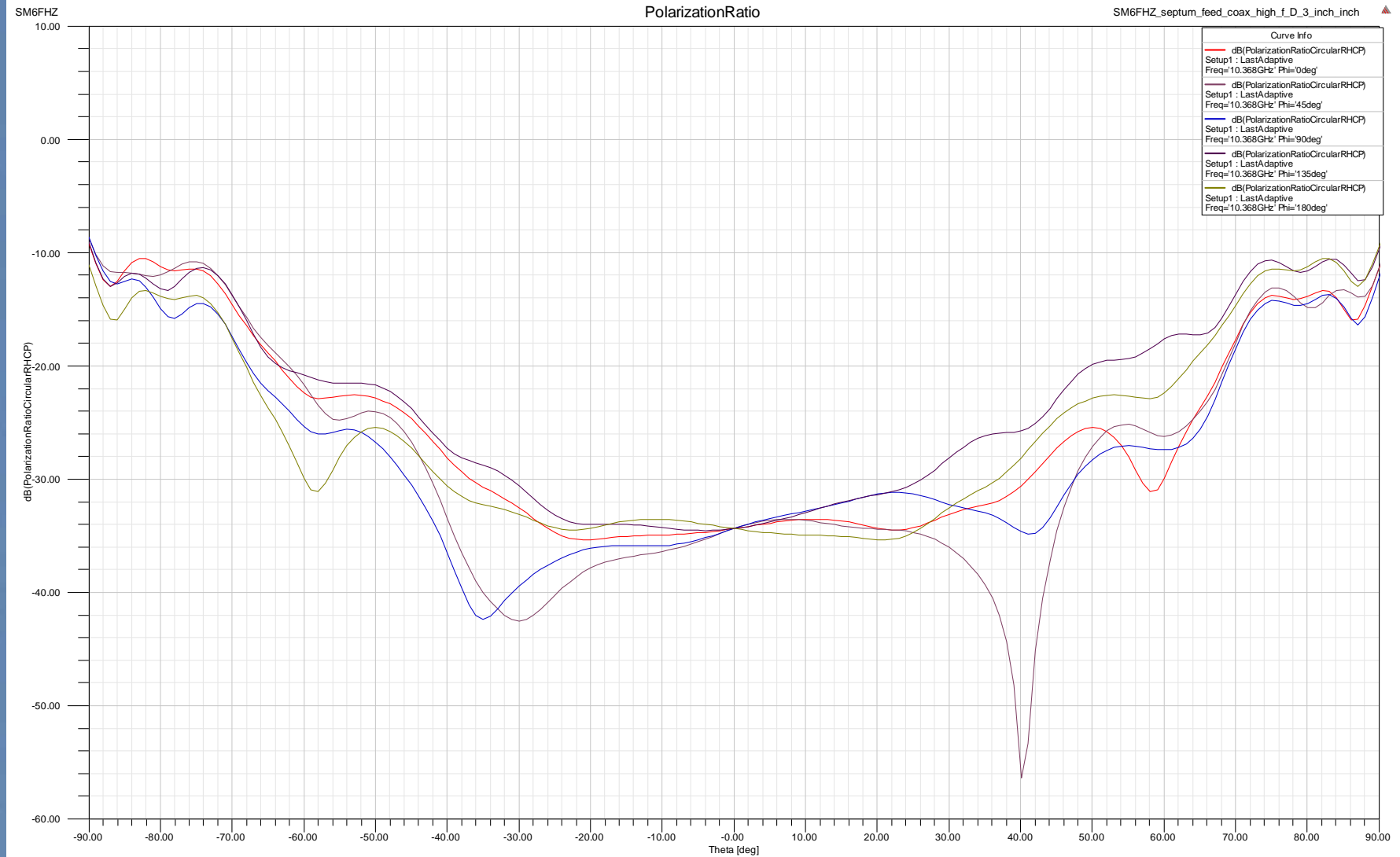

Axial Ratio (3 cm 0.760 wl WG Dual Mode 39mm inch tubing)

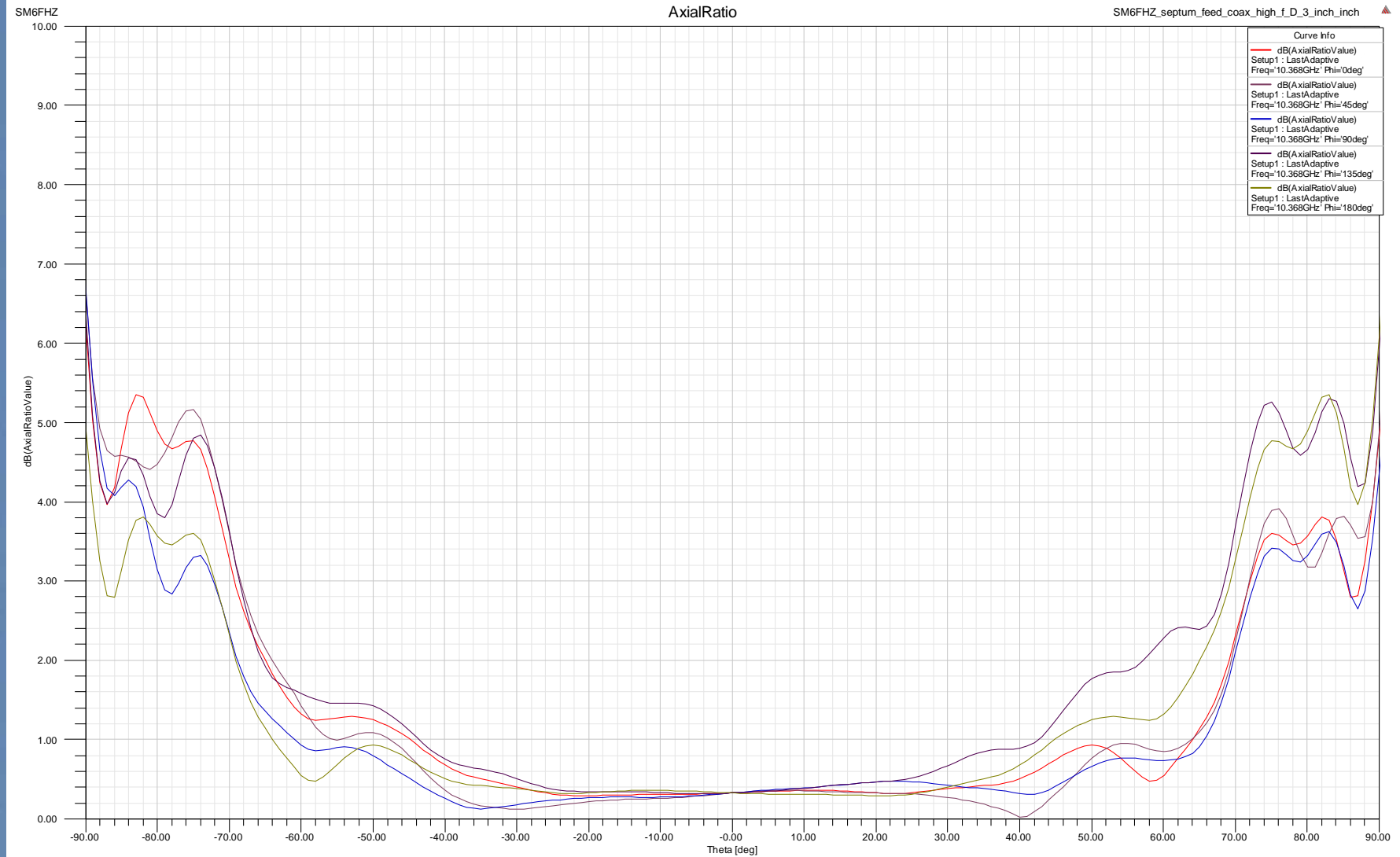

Revision history



- Rev A; As presented at The Swedish EME Meeting, May 2015